

Allied Tube & Conduit PVC Coated Conduit and Fittings

Submittal Package

Alterations to this document by any agency other than Atkore International voids the certification.



 	 E226472 RIGID METAL CONDUIT 26KT	
PVC Coated Hot-Dip Galvanized Metal Rigid Conduit		
2" x 10' PVC Coated Conduit		
PV2010CT00		
METAL RIGID CONDUIT PVC COATED HOT-DIP GALVANIZED	Made in USA 	
		<p>PVC COATING ETL VERIFIED TO INTERTEK ETL SEMKO HIGH TEMPERATURE H2O 200HR PVC COATING ADHESION TEST CERTIFICATE NUMBER: 104646226CRT-002</p> <p>PROPERTIES OF PVC INVESTIGATED AS PRIMARY CORROSION PROPERTIES OF ZINC INVESTIGATED AS PRIMARY CORROSION USE THREADED COUPLINGS ONLY.</p> <p>CONSULT MANUFACTURER FOR PROPER INSTALLATION</p>

Atkore™

Allied Tube & Conduit

Choose Allied... Affordable Corrosion Protection for Harsh Environments

Allied PVC Coated Conduit, Fittings and Accessories are easy to install and require little to no maintenance. At a *fraction of the cost* of stainless steel conduit, Allied PVC Coated Conduit provides the best protection for electrical raceway systems in extreme environments found in applications like oil and gas, mining and industrial wastewater treatment.



The Right Product for Your application:

- PVC Coated Rigid Steel and Aluminum
- UL Listed and NEMA RN -1 Compliant - no exceptions



Call a Allied expert or visit Alliedeg.us to better protect your electrical raceway system. 800-225-7473

Table of Contents

Allied Letter of Applicable Product Specifications..... 4
PVC Coated Product Specifications..... 6
Allied Standards Conformities 7
ETL Specifications..... 9
Certificate of Compliance..... 10
Product Submittal Sheets..... 11
Certified Installer Program 16
Job References..... 18



Allied Tube & Conduit, a division of Atkore, offers a complete line of PVC coated conduit, fittings and accessories for protection of electrical conduit systems in highly corrosive environments.

The Allied submittal package includes the following:

- Allied Letter of Product Specification
- Certificate of Compliance
- Allied Standards Conformities
- PVC Coated Conduit Specifications
- UL Certification Directory Files
- Product Submittal Sheets
- Job References
- Product Catalog

A complete list of product submittal sheets, electronic copy of product catalog and list of frequently asked questions (FAQs) can be found at www.Alliedeg.us, for your review.

Product samples can be supplied upon request. Please send requests to Mike Lang at mlang@atkore.com

If you have any questions, please feel free to contact me directly at the number below. Thank you for your consideration.

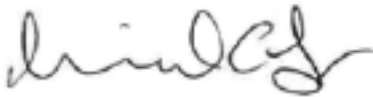

Michael Lang

Sr Product Manager

Allied Conduit & Tube
219-844-6800 x201

Design and Performance Requirements: PVC Coated Rigid Metal Conduit

- The PVC coated rigid metal conduit shall be hot dip galvanized inside and out. The interior galvanizing shall be listed per UL 6. The exterior galvanizing shall be listed per UL 6 as primary corrosion protection. Thread protectors shall be used on the exposed threads of the PVC coated conduit. PVC coated RMC steel conduit shall comply with UL 6, ANSI C80.1, and NEMA RN-1 standards without exception.
- The PVC coating, in compliance with NEMA RN-1, shall be nominal 40 mils in thickness continuous over the entire length of the conduit except at the threads, and be free of blisters, bubbles or pin- holes. PVC shall be UL listed as a primary corrosion protection.
- A urethane coating shall be uniformly and consistently applied to the interior of conduit. This internal coating shall be a nominal 2 mils thickness. All male threads on elbows and nipples shall be zinc coated using zinc rich paint.
- Coated couplings shall be used with coated conduit. The thickness of the coating on couplings shall be at least equal to the thickness of the coating on the conduit. Each coated coupling shall have a flexible PVC sleeve which extends from each end of the coupling and which will overlap the PVC coating on the conduit when the coupling has been installed on the conduit. The length of the sleeve extension(s) shall be at least equivalent to the nominal Trade Size for sizes ½" up through 1-½". For Trade Size 2" through 6", the length of the sleeve extension(s) shall be at least 2". The PVC sleeve shall be a nominal thickness of 40 mils in thickness. The inside diameter of the overlapping sleeve shall be less than the outside diameter of the PVC-coated conduit.

Design And Performance Requirements: PVC Coated Aluminum Conduit

- A. The PVC coated RMC Aluminum conduit prior to coating shall be UL Listed to UL 6A.
- B. The exterior of the conduit shall have a PVC coating of a minimum thickness of nominal 40 mils.
- C. A urethane coating shall be uniformly and consistently applied to the interior of conduit. This internal coating shall be a nominal 2-mils thickness.
- D. The ETL PVC001 adhesion performance test is comprised of two primary tests:
 1. Immersion in Boiling Water according to the intent of ASTM D 870, Testing the Water Resistance of Coatings Using Water Immersion, for a period of 200 hours
 2. Both the exterior and interior coating were tested for adhesion at predetermined intervals during the 200-hour test period.
- E. Coated couplings shall be used with coated conduit. The thickness of the coating on couplings shall be at least equal to the thickness of the coating on the conduit. Each coated coupling shall have a flexible PVC sleeve which extends from each end of the coupling and which will overlap the PVC coating on the conduit when the coupling has been installed on the conduit. The length of the sleeve extension(s) shall be at least equivalent to the nominal Trade Size for sizes ½" up through 1-½". For Trade Size 2" through 6", the length of the sleeve extension(s) shall be at least 2". The PVC sleeve shall be a nominal thickness of 40 mils in thickness. The inside diameter of the overlapping sleeve shall be less than the outside diameter of the PVC-coated conduit.

Allied Standards Conformities

I. Purpose

This document depicts and describes the standards conformities for Allied Tube and Conduit PVC Coated Conduit and Fittings.

II. Standards:

There are applicable standards for PVC-coated rigid steel conduit. Three standards govern the design and performance of PVC-coated rigid steel conduit. They are:

1. UL6
2. National Electrical Manufacturers Association (NEMA) RN-1
3. American National Standards Institute (ANSI) C80.1

All three of these standards reference the appropriate American Society for Testing and Materials (ASTM) standards and test methods. These are:

1. *ASTM D149 - 09 Standard Test Method for Dielectric Breakdown Voltage and Dielectric Strength of Solid Electrical Insulating Materials at Commercial Power Frequencies.*
2. *ASTM D1735 - 08 Standard Practice for Testing Water Resistance of Coatings Using Water Fog Apparatus.*
3. *ASTM D2247 - 11 Standard Practice for Testing Water Resistance of Coatings in 100% Relative Humidity.*
4. *ASTM D2240 - 05(2010) Standard Test Method for Rubber Property-Durometer Hardness.*
5. *ASTM D1308 - 02(2007) Standard Test Method for Effect of Household Chemicals on Clear and Pigmented Organic Finishes.*
6. *ASTM D638 - 10 Standard Test Method for Tensile Properties of Plastics.*
7. *ASTM D746 - 07 Standard Test Method for Brittleness Temperature of Plastics and Elastomers by Impact.*
8. *ASTM D1151 - 00(2006) Standard Practice for Effect of Moisture and Temperature on Adhesive Bonds.*
9. *ASTM D870 - 09 Standard Practice for Testing Water Resistance of Coatings Using Water Immersion.*
10. *ASTM G152 - 06 Standard Practice for Operating Open Flame Carbon Arc Light Apparatus for Exposure.*
11. *ASTM G153 - 04(2010) Standard Practice for Operating Enclosed Carbon Arc Light Apparatus for Exposure of Nonmetallic Materials.*
12. *ASTM D3359 - 09e2 Standard Test Methods for Measuring Adhesion by Tape Test.*
13. *ASTM D4585 - 07 Standard Practice for Testing Water Resistance of Coatings Using Controlled Condensation.*
14. *ASTM B571 - 97(2008)e1 Standard Practice for Qualitative Adhesion Testing of Metallic Coatings*

III. Corrosion Protection:

The effectiveness of corrosion protection requires an evaluation of the zinc-galvanized coating beneath the PVC coating and on threaded surfaces, as well as the adhesion of the PVC coating to the zinc. In cases where the PVC protection is accidentally breached, due to cuts, scrapes, or other damage, it is important to have a second line of defense - a zinc or "galvanized" coating. This zinc coating will and does significantly slow the corrosion, thereby allowing more time for repairs. Conduit systems without adequate zinc protection, underneath the PVC coating, are more likely to suffer corrosion damage. This is why NEMA RN-1, section 3.1.1 requires the proper and correct treatment of galvanized conduit before it is PVC coated. This standard states, "The surface shall be cleaned in such a manner that the galvanized surface of the conduit is not harmed or eroded." While the PVC may be UL listed as the primary corrosion protection, if the zinc coating is not adequate, the conduit does not comply with NEMA RN-1.

(*) Allied fully and completely complies.

IV. PVC Adhesion:

NEMA RN-1, Section 3.8, addresses the evaluation process for adhesion of PVC coating on conduit. It states, "The adhesion of the PVC coating to the conduit shall be greater than the strength of the coating itself. "In order for PVC-coated conduit to be UL listed with the PVC as the primary corrosion protection, UL 6 Section 6.2.4.9 (for adhesion), requires that "The adhesion of the alternate corrosion-resistant coating (PVC in this case) ... shall be greater than the strength of the alternate corrosion-resistant coating itself. "This adhesion test is straightforward and simple. Conduit that passes this test, detailed below, demonstrates that the adhesion will provide years of trouble-free service:

Step 1 consists of two cuts through the plastic to the substrate along the length of the conduit at approximately ½" apart, 3 to 4" in length. A third perpendicular cut crosses the lengthwise cuts.

Step 2 requires the edge of the PVC that was cut on the perpendicular to be carefully lifted to form a plastic tab.

Step 3 the tab is pulled perpendicular to the conduit with a pair of pliers. The plastic tab will break off rather than peel away, with no coating separating from the substrate.

(*) Allied fully and completely complies.

ETL Specification

intertek



3933 US Route 11
Cortland, New York 13045 USA
Phone Number: (800) 345-3851
Fax Number: (607) 758-6637
Web: www.intertek.com

Intertek

ETL Verified Certificate of Conformance Number: 104646226CRT-002

On the basis of the tests undertaken, the sample(s) of the below product have been found to comply with the essential requirements of the referenced specifications at the time the tests were carried out.

Rendered to:
Atkore

16100 South Lathrop Ave.
Harvey, IL 60426 USA
Contact Mr. Fred Small

Product Tested: PVC coated galvanized rigid steel conduit

Model(s) and or Brand Name: Allied Tube & Conduit, Calbond

Pipe Size	Catalog Number
½"	PV0510CT00
¾"	PV0710CT00
1"	PV1010CT00
1-¼"	PV1210CT00
1-½"	PV1510CT00
2"	PV2010CT00
2-½"	PV2510CT00
3"	PV3010CT00
3-½"	PV3510CT00
4"	PV4010CT00
5"	PV5010CT00
6"	PV6010CT00

Standard(s)/Specification: Intertek High Temperature H₂O PVC Coating Adhesion Test Procedure for 200 hours PVC coated galvanized rigid steel conduit

Product labeling may include: ETL Verified to Intertek High Temperature H₂O PVC Coating Adhesion Test Procedure for 200 hours PVC coated galvanized rigid steel conduit

Continuing compliance to this specification is monitored through production testing, on-going inspections by Intertek at the production facility and random sample testing.

Date Verified: 10/6/2021

Approved By:

Antoine Pelletier, Project Engineer

This verification supersedes all previous verifications with the noted Verification/Report number(s) dated before this verification notice.

NOTE: This verification is part of the full test report(s) and should be read in conjunction with it.

This Verification is for the exclusive use of Intertek's Client and is provided pursuant to the agreement between Intertek and its Client. Intertek's responsibility and liability are limited to the terms and conditions of the agreement. Intertek assumes no liability to any party, other than to the Client in accordance with the agreement, for any loss, expense or damage occasioned by the use of this Verification. Only the Client is authorized to copy or distribute this Verification. Any use of the Intertek name or one of its marks for the sale or advertisement of the tested material, product or service must first be approved in writing by Intertek. The observations and test results referenced from this Verification are relevant only to the sample tested. This Verification by itself does not imply that the material, product, or service is or has ever been under an Intertek certification program.

CERTIFICATE OF COMPLIANCE

Certificate Number 20161206-E226472
Report Reference E226472-20110128
Issue Date 2016-DECEMBER-06

Issued to: CALPIPE INDUSTRIES LLC
19440 S Dominguez Hills Dr
Rancho Dominguez CA 90220

**This is to certify that
representative samples of**

RIGID FERROUS METAL CONDUIT WITH POLYVINYL
CHLORIDE COATING VERIFIED

PVC coated Rigid ferrous metal conduits, nipples and
elbows in 1/2, 3/4, 1, 1-1/4, 1-1/2, 2, 2-1/2, 3, 4, 5 and 6
Trade Sizes.

Have been investigated by UL in accordance with the
Standard(s) indicated on this Certificate.

Standard(s) for Safety: UL 6 - Electrical Rigid Metal Conduit – Steel
CSA-C22.2 No.45.1-07 - Electrical Rigid Metal Conduit –
Steel

Additional Information: See the UL Online Certifications Directory at
www.ul.com/database for additional information

Only those products bearing the UL Certification Mark should be considered as being covered by UL's
Certification and Follow-Up Service.

Look for the UL Certification Mark on the product.



Bruce Mahrenholz, Director North American Certification Program

UL LLC

Any information and documentation involving UL Mark services are provided on behalf of UL LLC (UL) or any authorized licensee of UL. For questions, please
contact a local UL Customer Service Representative at <http://ul.com/aboutul/locations/>



16100 South Lathrop Avenue
Harvey, IL 60426
Office 708-339-1610
Phone 800-882-5543
Web atkore.com/atce

**DOMESTIC CERTIFICATE OF COMPLIANCE
BUY AMERICA
BUY AMERICAN
INFRASTRUCTURE INVESTMENT AND JOBS ACT (BABA)**

January 1, 2024

To Whom It May Concern:

This certifies that the following conduit and fittings supplied by Allied Tube & Conduit are manufactured in the United States from steel melted and manufactured in the United States. These products comply with the Buy America requirements of 49 U.S.C. 5323(j)(l) and the applicable regulations in 23 CFR part 635.410, the Buy American Act of 1933 (FAR 52.225, Sections 9-12), and the Infrastructure Investment and Jobs Act (Build America, Buy America) if requested when ordering.

Please indicate Domestic when ordering

PVC Coated Conduit
PVC Coated Couplings
PVC Coated Elbows
PVC Coated Nipples
PVC Coated Special Radius Elbows

*Some products will have the -DOM to indicate domestic

These products meet the following UL and ANSI standards:

PVC Coated Galvanized Rigid Conduit: UL 6, ANSI C80.1

This certification has been issued for only the products listed above for domestic compliance and is valid for 180 days. Alterations to this document by any agency other than Atkore International voids the certification.

For domestic compliance letters specific to a customer or project name, please contact IndustryAffairs@atkore.com for further assistance.

Atkore Industry Affairs Team

Direct **1.800.882.5543**

Email **Industryaffairs@atkore.com**

PVC Coated Conduit

PVC Coated Rigid Steel Conduit

Features:

- Exterior PVC coating thickness is a minimum 0.040"
- Interior urethane coating thickness is a minimum 0.002"
- Specialized corrosion resistant coating provided on threads
- Sizes available are ½" to 6"
- Color coded thread protectors
- Couplings shipped with conduit are packaged separately
- Hot Dipped Galvanized (HDG) conduit

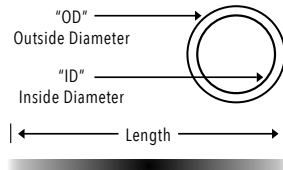

Applications:

Allied PVC Coated Conduit is used for highly corrosive environments to protect electrical circuits in harsh environments. The coating is Intertek SEMKO ETL PVC-001 Verified for superior corrosion and mechanical protection. Ground continuity is maintained throughout the installation.

Certifications and Compliances:

Allied PVC Coated Conduit is UL Listed with both the PVC coating as a primary protection and the Hot Dipped Galvanized (HDG) zinc coating as the primary protection per UL6. PVC coated conduit is restricted for use with threaded fittings only (threadless connector not permitted).

- UL/cUL listed, File # DYJC E226472
- ETL PVC-001 adhesion performance test verified / Cert. of Conformance Number: 104646226CRT-002
- Exceeds NEMA RN-1 and ANSI c80.1 Standards



Part Number	ETL - Part Number	Trade Size (in)	Metric Size (mm)	Wall Thickness (in)	Outside Diam. w/ Coating (in)	Inside Diam. (in)	Weight / 100 (lbs)	Feet/ Bundle
PV0510CT00	PV0510CT00 -E	½	16	0.104	0.920	0.632	90	1,000
PV0710CT00	PV0710CT00 -E	¾	21	0.107	1.130	0.836	119	900
PV1010CT00	PV1010CT00 -E	1	27	0.126	1.395	1.063	175	750
PV1210CT00	PV1210CT00 -E	1¼	35	0.133	1.740	1.394	237	420
PV1510CT00	PV1510CT00 -E	1½	41	0.138	1.980	1.642	281	380
PV2010CT00	PV2010CT00 -E	2	53	0.146	2.455	2.083	376	300
PV2510CT00	PV2510CT00 -E	2½	63	0.193	2.955	2.489	593	170
PV3010CT00	PV3010CT00 -E	3	78	0.205	3.580	3.090	772	140
PV3510CT00	PV3510CT00 -E	3½	91	0.215	4.080	3.570	922	110
PV4010CT00	PV4010CT00 -E	4	103	0.225	4.580	4.050	1,089	110
PV5010CT00	PV5010CT00 -E	5	129	0.245	5.643	5.073	1,488	80
PV6010CT00	PV6010CT00 -E	6	155	0.266	6.705	6.093	1,998	50

All dimensions are for informational purposes only *Tolerances +/- 5%

PVC Coated GRC 90° Standard Elbows

Features:

- Exterior PVC coating thickness is a minimum 0.040"
- Interior urethane coating thickness is a minimum 0.002"
- Specialized corrosion resistant coating provided on threads
- Sizes available are ½" to 6"
- Available in 90, 60, 45, and 30 degree bands

Applications:

Allied PVC Coated GRC 90° Standard Elbows are available in standard & special radius dimensions and in various degrees as required. All elbows are manufactured from Allied PVC coated conduit and meet all applicable standards.

Certifications and Compliances:

- UL/CUL listed in accordance to UL6 & ANSI C80.1 Standards
- UL/cUL listed rigid ferrous metal conduit with polyvinyl chloride coating verified for PVC adhesion performance
- Complies with NEMA RN-1
- UL File # E226472

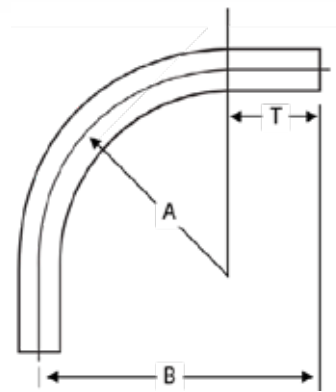

Part Number	Trade Size (in)	Metric Size (mm)	A Standard Radius (in)	B Offset (in)	T Tangent (in)	Weight per 100 (lbs)
PV0590EL00	½	16	4.250	6.000	1.700	70
PV0790EL00	¾	21	4.500	6.700	2.200	100
PV1090EL00	1	27	5.750	8.000	2.400	190
PV1290EL00	1¼	35	7.250	9.600	2.800	310
PV1590EL00	1½	41	8.250	10.600	2.600	400
PV2090EL00	2	53	9.500	12.000	3.500	640
PV2590EL00	2½	63	10.500	14.800	4.700	1,210
PV3090EL00	3	78	13.000	17.000	5.300	1,950
PV3590EL00	3½	91	15.000	20.900	6.100	2,630
PV4090EL00	4	103	16.000	21.000	6.500	3,280
PV5090EL00	5	129	24.000	32.000	11.200	6,750
PV6090EL00	6	155	30.000	41.000	12.100	10,510

All dimensions are for informational purposes only *Tolerances +/- 5%

PVC Coated Conduit

PVC Coated Couplings

Features:

- Exterior PVC coating thickness is a minimum 0.040"
- Interior urethane coating thickness is a minimum 0.002"
- Sealing sleeves on both ends
- All couplings have straight threads (not tapered)
- Galvanized Ridgid Couplings

Applications:

Allied PVC Coated Rigid Couplings are supplied with PVC sleeves on both ends to ensure corrosion protection for the entire system.

Certifications and Compliances:

- Ferrous electrical conduit with PVC coating:
File # DYJC.E226472

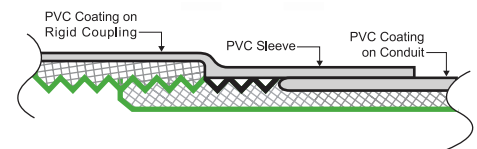

Part Number	Trade Size (in)	Metric Size (mm)	Length of Metal (in)	Threads per Inch	Weight per 100 (lbs)	Box Qty
PV0500CP00	½	16	1.500	14	19	100
PV0700CP00	¾	21	1.532	14	32	90
PV1000CP00	1	27	1.906	11½	40	75
PV1200CP00	1¼	35	1.906	11½	50	42
PV1500CP00	1½	41	1.906	11½	69	38
PV2000CP00	2	53	1.937	11½	93	30
PV2500CP00	2½	63	2.878	8	123	17
PV3000CP00	3	78	3.031	8	217	14
PV3500CP00	3½	91	3.094	8	422	11
PV4000CP00	4	103	3.188	8	391	11
PV5000CP00	5	129	3.374	8	550	8
PV6000CP00	6	155	3.437	8	884	5

All dimensions are for informational purposes only *Tolerances +/- 5%

PVC Coated Conduit Hubs

Features:

- Exterior PVC coating thickness is a minimum 0.040"
- Interior urethane coating thickness is a minimum 0.002"
- ST available in 12 trade sizes from ½" through 6"
- Sealing sleeves on conduit side of hub
- Sizes available are ½" to 2"
- For sizes 2½" - 6", the length of the sleeve extension(s) shall be at least 2"

Applications:

Allied PVC Conduit Hubs are used to terminate conduit runs into electrical enclosures. Conduit hubs are available with or without grounding lug. PVC coating and internal urethane coating provide for superior corrosion protection. Electrical continuity is maintained across assembled joints.



Certifications and Compliances:

- UL Listed File #E308159
- NEC/CEC:
 - Class I, Division 2,
 - Class II, Division 1 & 2
 - Class III, Division 1 & 2
 - Class I, Zone 1, AEx e II
 - Class I, Zone 1, Ex e II
- All Screw-tight Hubs are manufactured in accordance with NEMA type enclosures 2, 3, 3R, 4, 4x, 11 and 12



Part Number	Trade Size (in)	A (in)	B (in)	C (in)	Max Wall Thickness (in)	Weight Per 100 (lbs)
PV0500ST1	½	1.84	2.00	1.31	0.125	20
PV0700ST2	¾	2.22	2.25	1.66	0.125	30
PV1000ST3	1	2.66	2.50	2.03	0.125	40
PV1200ST4	1¼	2.94	3.25	2.28	0.125	40
PV1500ST5	1½	3.19	3.50	2.53	0.125	60
PV2000ST6	2	3.75	4.25	3.09	0.125	120
PV2500ST7	2½	4.22	4.75	3.28	0.125	150
PV3000ST8	3	4.31	5.25	3.38	0.125	210
PV3500ST9	3½	4.38	5.50	3.44	0.125	300
PV4000ST10	4	4.44	6.25	3.50	0.125	350
PV5000ST11	5	4.94	7.50	4.00	0.125	540
PV6000ST12	6	5.00	8.50	4.00	0.125	690

All dimensions are for informational purposes only *Tolerances +/- 5%

PVC Coated Conduit

PVC Coated Conduit Bodies - LB Form 8

Features:

- Exterior PVC coating thickness is a minimum 0.040"
- Interior urethane coating thickness is a minimum 0.002"
- Specialized corrosion resistant coating provided on threads
- Fittings are supplied with plastic encapsulated stainless steel screws
- Sizes available are 1/2" to 4"

Applications:

Allied offers the full line of LB Form 7 PVC Coated Conduit Bodies. Conduit Bodies are installed in conduit systems to; act as pull outlets for conductors being installed, provide openings for making splices in conductors, and to provide access to conductors for maintenance and future system changes. All fittings are supplied with PVC coated cast iron covers. The sleeved threaded ends offer complete protection against corrosion while maintaining full ground continuity throughout the installed system.



Certifications and Compliances:

- UL Listed Standard 514B
- UL Listed File # E307133
- CSA Standard: C22.2 No. 18
- Verified NEMA 4X Rated

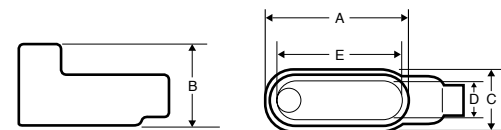

Part Number	Trade Size (in)	Metric Size (mm)	A (in)	B (in)	C (in)	D (in)	E (in)	Weight / 100 (lbs)
PV0500LB18	1/2	16	5.48	2.26	1.42	1.00	3.31	150
PV0700LB28	3/4	21	6.35	2.48	1.60	1.19	3.94	200
PV1000LB38	1	27	7.51	2.85	1.79	1.38	4.56	290
PV1200LB48	1 1/4	35	8.82	3.38	2.23	1.75	5.31	410
PV1500LB58	1 1/2	41	10.67	4.07	2.79	2.13	6.50	650
PV2000LB68	2	53	13.04	4.85	3.79	3.00	8.56	829
PV2500LB78	2 1/2	63	15.98	6.17	5.04	4.25	10.88	1,820
PV3000LB888	3	78	15.98	6.54	5.04	4.25	10.88	2,120
PV3500LB98	3 1/2	91	14.73	7.60	6.29	5.44	13.44	3,120
PV4000LB108	4	103	14.73	7.85	6.29	5.44	13.44	3,200

All dimensions are for informational purposes only *Tolerances +/- 5%

Course Overview

The Allied Certified Installer Program provides the proper procedures and proven techniques to ensure a quality corrosion resistant conduit system. With proper installation, one can expect a long lasting, superior corrosion resistant conduit system that requires little to no maintenance.

Course Content

Standards Review

- ▶ Review of the industry standards applicable to PVC coated conduit systems.

Field Installation Topics

- ▶ **Cutting**
 - Highlight the various tools and techniques for cutting and preparing coated conduit for threading and bending in field setting.
- ▶ **Clamping**
 - Demonstrate proper use of recommended clamping devices and additional tools required to ensure integrity of PVC coating over UL galvanized rigid conduit GRC.
- ▶ **Threading**
 - List the appropriate threading tools and machinery for each trade size of coated conduit.
- ▶ **Bending**
 - Proper bending techniques for custom field bending on coated conduit.
- ▶ **Repair**
 - Recommended procedures for repairing areas of damaged coating on PVC coated conduit systems. Properly repaired coating is essential for a long lasting corrosion resistant system.
- ▶ **Certification Process**
 - Written examination.

Class Curriculum

Certified Installer Program

- ▶ 30 minutes - Plant Operations Tour
- ▶ 1 hour - Classroom Instruction: Understanding Corrosion and its Consequences and Prevention
- ▶ 2 hours - Training Center - Hands-on Training
- ▶ 1 hour - Classroom Instruction - Standards, Installation Tools
- ▶ 30 minutes - Written Test Administered
- ▶ Closing - Presentation of Course Completion Materials

65% Practical 35% Theory

Qualification

- Allied Certified Installer

Who should attend

- Installers and electricians who install Allied PVC Coated Conduit Systems

Benefits of attending the course

- Quality installation by trained professionals
- Meet industry specifications requiring certified installers of PVC coated conduit systems
- Lower Cost of Ownership
- Extends product warranty from 2 years to 5 years

Course objectives

- To have a full understanding for current applicable specifications along with the skills and expertise to install Allied PVC Coated Conduit Systems

Prerequisites

- Suggested 2 years experience installing PVC coated conduit systems

Course locations

- Santa Paula, CA
- Hobart, IN
- * On-Site Training requires minimum of 5 participants. Pre-registration and a \$100/ per attendee fee that will be applied to next purchase of Allied.

Job References

Denver International Airport
9100 Pena Ave
Denver CO 80249
6 / 8 / 20

Amazon Hub
191 Wandell H. Ford Blvd
Erlander, KY 41018
1 / 18 / 21

Canonsburg WWTP
315 Curry Hill Rd
Canonsburg, PA 15317
2 / 3 / 21

Natural Fuel Gas Co
350 Hemstreet Rd
East Aurora, NY 14052
3 / 17 / 21

Fargo WWTP
3400 Broadway N
Fargo, ND 58102
2 / 16 / 21

New Jersey Turnpike
East Rutherford NJ 08846
10 / 8 / 21





Allied Tube & Conduit ^ AFC Cable Systems ^ Heritage Plastics ^ Unistrut
Unistrut Construction ^ Cope ^ US Tray ^ Calbrite ^ Calbond ^ Kaf-Tech
Columbia-MBF ^ Eastern Wire + Conduit ^ ACS/Uni-Fab ^ Marco
Power-Strut ^ Calconduit ^ Razor Ribbon ^ Calpipe Security ^ Cii
FRE Composites ^ Queen City Plastics ^ Vergokan ^ Flexicon

Atkore
6451 Northwind Pkwy
Hobart, IN 46342

TOLL FREE / 800-844-6884
FAX / 219-536-2248

alliedeg.us

Want to join a company that helps you build
the mindset, skill set and tool set for success?
Visit us at atkore.com/careers