

# Cor-Tek™

## Submittal Package

Alterations to this document by any agency other than Atkore International voids the certification.



**Atkore™**  
Allied Tube  
& Conduit

# Cor-Tek™ Cellular Core Conduit

Cellular Core conduit is manufactured using the same resin as solid wall PVC, through a co-extrusion process that creates three firmly bonded layers. Two of these layers are traditional solid wall skin, the third inner layer is the cellular core. The expanded cell structure of the cellular core creates a conduit that weighs less and is more flexible, while still meeting UL standards.

It's a great solution for large diameter high volume projects or if the job consists of multiple duct banks, significant elevation changes or bending challenges. Cellular Core conduit is available in 3-6 inch diameters for both schedule 40 and 80 conduit in 10-20 foot lengths.

## Features and Benefits

- Meets UL 651 performance standards
- 25% lighter on average compared to traditional PVC
- More flexible, allowing tighter radius field bends and reducing the need for external heat sources
- Less brittle in cold weather environments, reducing field breakage during handling and installation. Interchangeable with standard schedule 40/80 stock fittings.

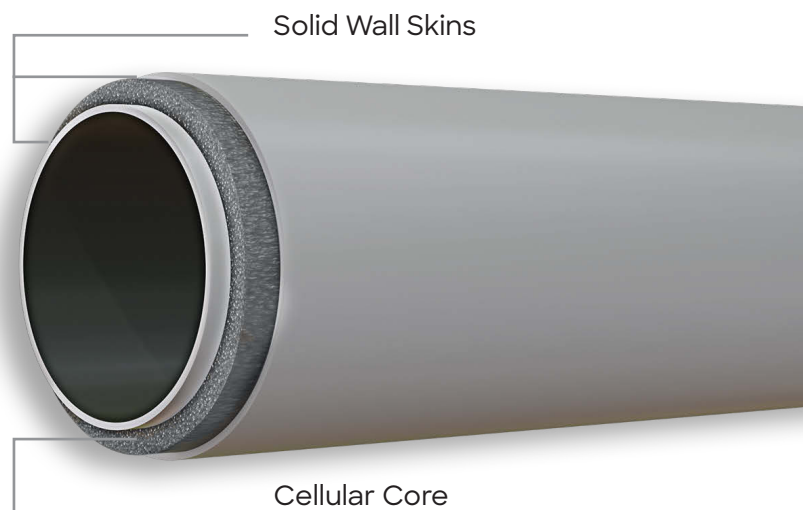

# Schedule 40 Cellular Core Rigid PVC Conduit

## Cor-Tek™

### Conforms to UL 651 and NEMA TC 2

- Rated for use with 90 degree C wiring
- Sunlight resistant per UL 651

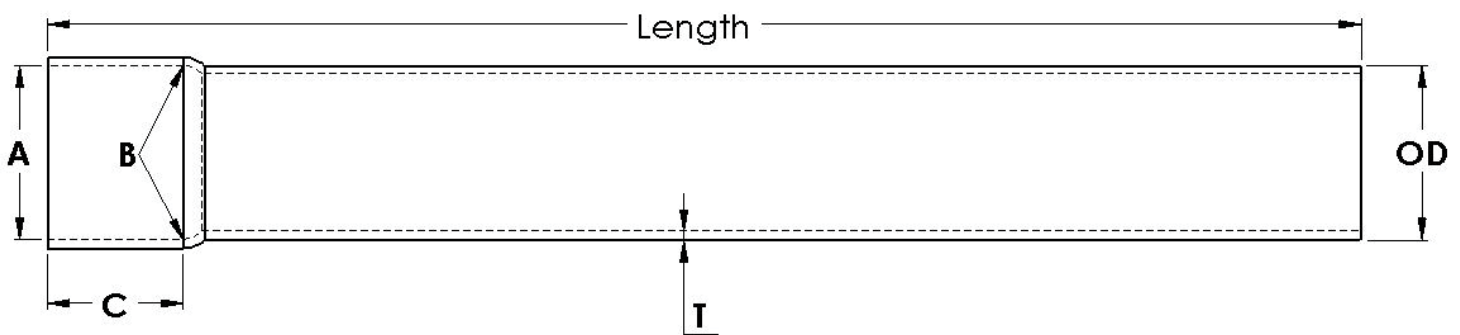

Trade Size	Part Number		Dimensions (in)			Bell Dimensions (in)			Approximate Weight per 100' (lbs)	Crate Quantity (ft)	
	10-foot	20-foot	Avg OD	Min Avg ID	Min Wall Thickness	A	B	C		10-foot	20-foot
<b>Cellular Core</b>											
3	4030010COR	4030020COR	3.500	3.008	0.216	3.515	3.492	4.00	124	880	1,760
3½	4035010COR	4035020COR	4.000	3.486	0.226	4.015	3.992	4.00	153	630	1,260
4	4040010COR	4040020COR	4.500	3.961	0.237	4.515	4.491	5.00	167	570	1,140
5	4050010COR	4050020COR	5.563	4.975	0.258	5.593	5.553	5.75	231	380	760
6	4060010COR	4060020COR	6.625	5.986	0.280	6.658	6.614	6.50	316	260	520

Standard UL 651 and NEMA TC-3 conduit fittings are used with both Solid Wall and Cellular Core conduit

# Schedule 80 Cellular Core Rigid PVC Conduit

## Cor-Tek™

### Conforms to UL 651 and NEMA TC 2

- Rated for use with 90 degree C wiring
- Sunlight resistant per UL 651

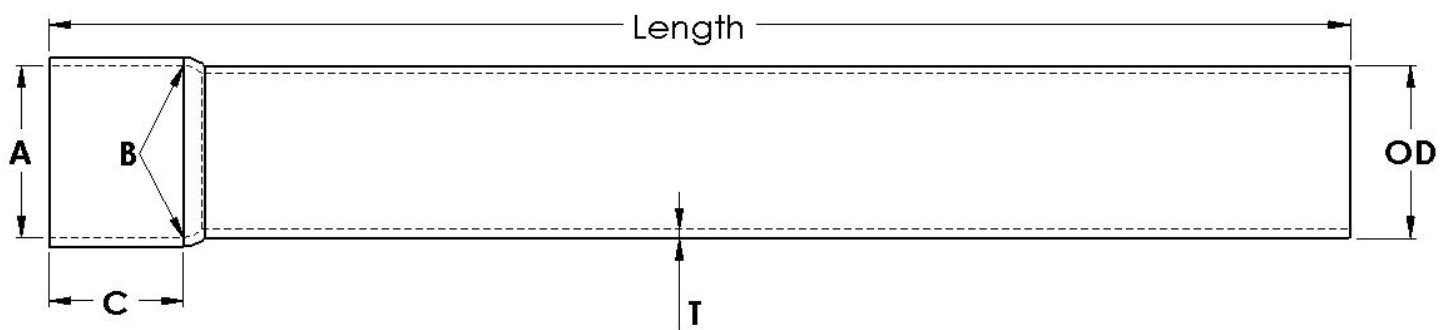

Trade Size	Part Number		Dimensions (in)			Bell Dimensions (in)			Approximate Weight per 100' (lbs)	Crate Quantity (ft)	
	10-foot	20-foot	Avg OD	Min Avg ID	Min Wall Thickness	A	B	C		10-foot	20-foot
<b>Cellular Core</b>											
3	8030010COR	8030020COR	3.500	2.820	0.300	3.515	3.492	4.00	165	880	1,760
4	8040010COR	8040020COR	4.500	3.737	0.337	4.515	4.491	5.00	236	570	1,140
5	8050010COR	8050020COR	5.563	4.713	0.375	5.593	5.553	5.75	299	380	760
6	8060010COR	8060020COR	6.625	5.646	0.432	6.658	6.614	6.50	448	260	520

Standard UL 651 and NEMA TC-3 conduit fittings are used with both Solid Wall and Cellular Core conduit

## Cor-Tek

This product specification is written according to the Construction Specifications Institute  
*MasterFormat*, 2018 Update.

### SECTION 26 05 33.13

## CONDUIT FOR ELECTRICAL SYSTEMS – Schedule 40 / Schedule 80 Cellular Core PVC Conduit

### PART 1 - GENERAL

#### 1.1 RELATED DOCUMENTS

- A. Drawings and general provisions of the Contract, including General and Supplementary Conditions and Division 01 Specification Sections apply to this Section.

#### 1.2 SUMMARY

- A. This Section includes the following:
- B. Schedule 40 and Schedule 80 Cellular Core PVC conduit
- C. Related Sections
  - 1. Section 26 05 26 “Grounding and Bonding for Electrical Systems”
  - 2. Section 26 05 29 “Hangers and Supports for Electrical Systems”
  - 3. Section 26 05 33.16 “Boxes for Electrical Systems”
  - 4. Section 27 05 33 “Conduits and Backboxes for Communications Systems”
  - 5. Section 25 05 28.33 “Conduits and Backboxes for Integrated Automation”

#### 1.3 REFERENCES

- A. UL 651 Safety Standard– *Schedule 40, 80, Type EB and A Rigid PVC Conduit and Fittings*
- B. NEMA TC-2 *Electrical Polyvinyl Chloride (PVC) Conduit*
- C. NEMA TC-3 *Polyvinyl Chloride (PVC) Fittings for Use with Rigid PVC Conduit and Tubing*
- D. NFPA 70 – *National Electrical Code® (NEC®)*
- E. NECA NEIS 111 – *National Electrical Installation Standard for Installing Nonmetallic Raceways*

#### 1.4 SUBMITTALS

- A. Manufacturer’s Product Data
- B. Certifications to applicable standards
- C. Domestic certifications: When required to Buy American Act or Buy America Act, comply with the provisions of Section 01 33 13

## 1.5 QUALITY ASSURANCE

- A. Schedule 40 and Schedule 80 Cellular Core PVC Conduit shall be listed to UL 651 and manufactured in accordance with NEMA TC-2 (conduit).
- B. Electrical equipment and materials shall be new and within one year of manufacture, complying with the latest codes and standards. No used, re-built, refurbished and/or re-manufactured electrical equipment and materials shall be furnished on this project.
- C. Testing Agency Qualifications: Testing/listing agency shall be one of the following Nationally Recognized Testing Laboratories:
  - 1. Underwriters Laboratories (UL)
  - 2. Intertek Testing Services (ETL)
  - 3. NSF International

## 1.6 STORAGE AND HANDLING

- A. Storage: Whenever possible, store the conduit indoors to prevent possible discoloration, the accumulation of dirt and to extend the life of the product. If conduit is stored outdoors, it shall be stored in such a way as to allow air circulation and water drain-off and shall not be directly covered with plastic.
- B. Schedule 40 and Schedule 80 Cellular Core PVC conduit shall be listed to UL 651 for use outdoors and where exposed to direct sunlight.

## PART 2 – PRODUCTS

### 2.1 BRANDS

- A. Cor-Tek

### 2.2 SCHEDULE 40 AND SCHEDULE 80 CELLULAR CORE PVC CONDUIT

- A. Cellular Core PVC Conduit shall be available in trade sizes 3” – 6”.
- B. Cellular Core PVC Conduit shall be listed to UL 651 and manufactured in accordance with NEMA TC-2.
- C. Cellular Core PVC Conduit shall be labeled or marked showing evidence of third-party listing to product standard.
- D. Cellular Core PVC Conduit shall be listed as sunlight resistant.
- E. Cellular Core PVC Conduit shall be listed for use with 90° conductors.

### 2.3 INTEGRAL COUPLINGS

- A. Integral couplings shall be listed to UL 651 and manufactured in accordance with NEMA TC-2.

### 2.4 ELBOWS

- A. Standard UL 651 conduit elbows are used with both Solid Wall and Cellular Core conduit
- B. Elbows shall be listed to UL 651 and manufactured in accordance with NEMA TC-3.

## 2.5 FITTINGS

- A. Standard UL 651 and NEMA TC-3 conduit fittings are used with both Solid Wall and Cellular Core conduit
- B. Fittings, including fabricated fittings, junction-box adapters, expansion joints, threaded adapters and service entrance heads shall be listed to UL 651 and manufactured in accordance with NEMA TC-3.
- C. Fittings for use in wet locations shall be listed for use in wet locations.

## PART 3 – EXECUTION

### 3.1 INSTALLATION

- A. Cellular Core Schedule 40 and Schedule 80 PVC Conduit shall be installed in compliance with the latest version of the National Electrical Code® (NEC®) and other applicable codes and standards as indicated elsewhere in these specifications.
- B. Cellular Core Schedule 40 and Schedule 80 PVC Conduit shall be installed in accordance with NECA National Electrical Installation Standard (NEIS) 111, *Standard for Installing Nonmetallic Raceways*.
- C. Cellular Core Schedule 40 PVC conduit shall be acceptable where not subject to physical damage.
- D. Cellular Core Schedule 80 PVC conduit shall be acceptable where subject to physical damage.



16100 South Lathrop Avenue  
Harvey, IL 60426

Office 708-339-1610

Phone 800-882-5543

Web atkore.com

**CERTIFICATE OF CONFORMANCE  
BUY AMERICA, BUY AMERICAN  
INFRASTRUCTURE INVESTMENT AND JOBS ACT (BABA)  
PVC ELECTRICAL CONDUIT**

January 1, 2024

To Whom It May Concern:

This certifies that Rigid Schedule 40 and Schedule 80 PVC electrical conduit and Elbows supplied by Atkore Plastic Pipe Corporation complies with the Buy America requirements of 49 U.S.C. 5323(j)(1) and the applicable regulations in 49 CFR part 661, with the Buy American Act of 1933 (FAR 52.225, Sections 9-12) and Buy American Preferences under 49 U.S.C. §50101, and of The Build America Buy America Act. For domestic compliance letters specific to a customer, project name, or PVC fittings, please contact [IndustryAffairs@atkore.com](mailto:IndustryAffairs@atkore.com) for further assistance.

Atkore Plastic Pipe Corporation is made up of the following manufacturers: Heritage Plastics, Allied Tube & Conduit, and Cor-Tek. Rigid Schedule 40 and Schedule 80 PVC conduit supplied by Atkore Plastic Pipe Corporation may be branded Heritage/Allied/Cor-Tek/Queen City Plastics. It is all listed to UL Safety Standard 651 but may be marked with a certification mark from Underwriters Laboratories (UL), Intertek (ETL) or National Sanitation Foundation (NSF).

The UL, NSF, or ETL mark on Atkore PVC conduit verifies that it has been independently tested by a Nationally Recognized Testing Laboratory (NRTL) and is compliant with the appropriate safety standard (UL 651). In addition, the mark indicates that the manufacturing site has been audited by the testing agency and meets follow-up inspections for verification of continued conformance to the standard.

Atkore Schedule 40 and Schedule 80 PVC conduit meet and/or exceed performance standards set by NEMA and UL. Atkore PVC electrical conduit is typically used for industrial, commercial, and residential applications. These include, but are not limited to, residential single and multi-family dwellings, and street and highway lighting.

Atkore PVC electrical conduit is manufactured from PVC compounds complying with the UL 651 standard in standard specifications for rigid PVC compounds ASTM D 1784 (cell classification 12123). Our PVC electrical conduit is subject to in-process quality control to assure compliance with appropriate manufacturing and performance standards.

Atkore PVC electrical conduit conforms to NEMA TC-2, is listed to UL 651, and allowed for use with 90° C conductors in accordance with the National Electrical Code®. It also meets all requirements from the UL 651 standard "Sunlight Resistance Rating"

Atkore electrical conduit is manufactured in Eugene and Pendleton, OR; Kirkwood, NY; Louisville, KY; Milford, UT; Tampa, FL; Thomasville, GA; Fort Mill, SC; and Weatherford and Dallas, TX.

This certification has been issued for only the products listed above for domestic compliance and is valid for 180 days. Alterations to this document by any agency other than Atkore International, Inc. voids the certification.

Please contact me with any questions regarding this certification.

**Atkore Industry Affairs Team**

Direct **1.800.882.5543**

Email **Industryaffairs@atkore.com**



# ENVIRONMENTAL PRODUCT DECLARATION

IN ACCORDANCE WITH ISO 14025 AND ISO 21930:2017, OPT. EN 15804+A2

SmartEPD-2024-021-0125-01

## Cellular Core PVC Conduit

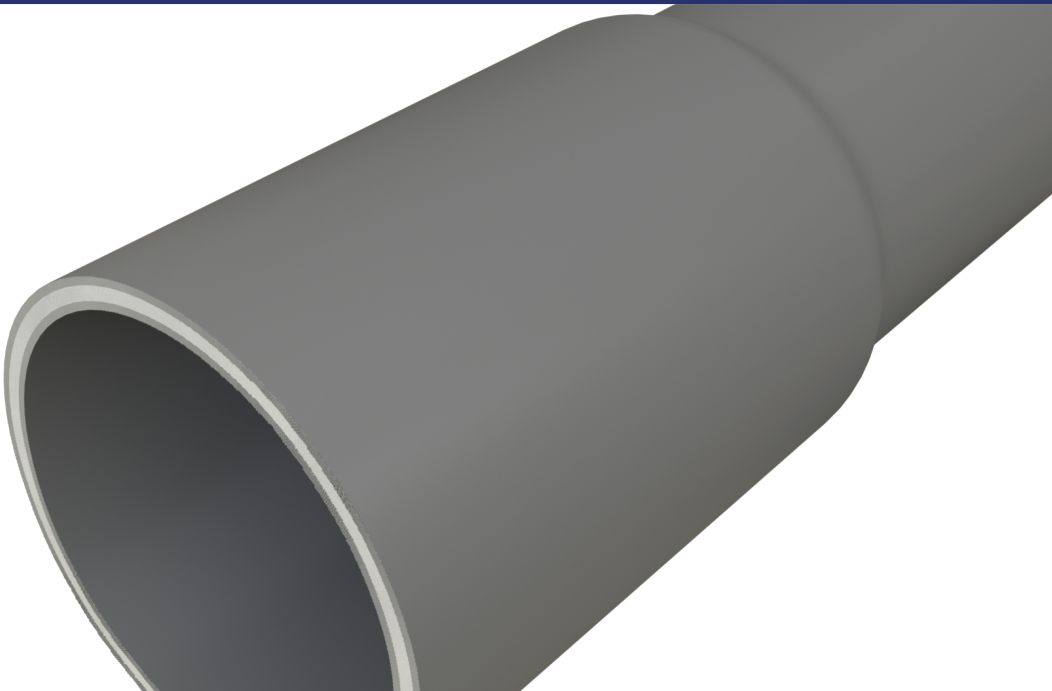

**Date of Issue:**  
May 14, 2024

**Expiration:**  
May 14, 2029

**Last updated:**  
May 15, 2024



## General Information

### Atkore

📍 16100 South Lathrop Ave, Harvey, IL, 60426

📞 (708) 915 1547

✉️ rhorner@atkore.com 🌐 [atkore.com](https://www.atkore.com)

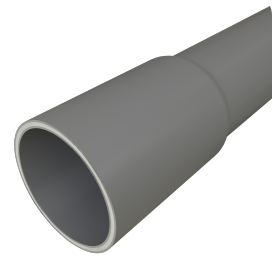

Product Name:	Cellular Core PVC Conduit
Declared Unit:	1 m of conduit product
Declaration Number:	SmartEPD-2024-021-0125-01
Date of Issue:	May 14, 2024
Expiration:	May 14, 2029
Last updated:	May 15, 2024
EPD Scope:	Cradle to gate with other options A1 - A3, C1 - C4, D
Market(s) of Applicability:	North America

## Reference Standards

Standard(s):	ISO 14025 and ISO 21930:2017, opt. EN 15804+A2
Core PCR:	Smart EPD® Part A Product Category Rules for Building and Construction Products and Services v.1.01, ISO 21930:2017 Date of issue: January 15, 2024
Sub-category PCR:	Smart EPD® Part B PCR for Electrical and Telecommunications Conduit v.1 Date of issue: January 31, 2024 Valid until: January 31, 2029
Sub-category PCR review panel:	📄 Contact Smart EPD for more information.
General Program Instructions:	📄 Smart EPD General Program Instructions v.1.0, November 2022

## Verification Information

ACLCA PCR Guidance Version:	2022 ACLCA PCR Guidance Process and Methods Toolkit version 1.0
ACLCA PCR Conformance Level:	Transparency
LCA Author/Creator:	🌐 Matthew Neiman   ✉️ <a href="mailto:matt.neiman@truenorthcollective.net">matt.neiman@truenorthcollective.net</a>
EPD Program Operator:	📄 Smart EPD   ✉️ <a href="mailto:info@smartepd.com">info@smartepd.com</a>   🌐 <a href="https://www.smartepd.com">www.smartepd.com</a>   📍 585 Grove St., Ste. 145 PMB 966, Herndon, VA 20170, USA

**Verification:**

Independent critical review of the LCA and data, according to ISO 14044 and ISO 14071 :

External

🌐 Nicole Kennard | 🏢 Consultant | ✉ nicolejjk.17@gmail.com

Independent external verification of EPD, according to ISO 14025 and reference PCR(s) :

External

🌐 Nicole Kennard | 🏢 Consultant | ✉ nicolejjk.17@gmail.com

## Limitations, Liability, and Ownership

The EPD owner has sole ownership, liability, and responsibility for the EPD.

Environmental declarations from different programs (ISO 14025) may not be comparable. Comparison of the environmental performance of products using EPD information shall be based on the product's use and impacts at the building or construction works level, and therefore EPDs may not be used for comparability purposes when not considering the whole building life cycle. EPD comparability is only possible when all stages of a life cycle have been considered. However, variations and deviations are possible. Example of variations: Different LCA software and background LCI datasets may lead to differences in results upstream or downstream of the life cycle stages declared.

The environmental impact results of products in this document are based on a declared unit and therefore do not provide sufficient information to establish comparisons. The results shall not be used for comparisons without knowledge of how the physical properties of the product impact the precise function at the construction level. The environmental impact results shall be converted to a functional unit basis before any comparison is attempted.

## Organization Information

Atkore is a leading manufacturer of electrical and critical infrastructure products for commercial, industrial, data center, telecommunications, water, and solar applications. Significant product categories include metal conduit, plastic conduit, electrical cable and flexible conduit, metal framing, and cable management systems.

Further information can be found at: <https://www.atkore.com/>

## Product Description

Cor-Tek™ PVC Schedule 40 and Schedule 80 Rigid Conduit has a cellular core, is up to 25% lighter than standard solid-wall PVC conduit, and is more flexible than standard PVC conduit for tighter field bends. It conforms to UL 651 and NEMA TC 2, making it suitable for above-ground and underground applications. Offered as Atkore brands Allied Tube & Conduit, Heritage Plastics, and Queen City Plastics.

Further information can be found at: <https://www.atkore.com/Products/Conduit/PVC-Conduit/PVC-Schedule-40-Cellular-Core-Rigid-Conduit>  
<https://www.atkore.com/Products/Conduit/PVC-Conduit/PVC-Schedule-80-Cellular-Core-Rigid-Conduit>

## Product Information

Declared Unit:	1 m of conduit product
Mass:	2.49 kg
Product Specificity:	✓ Product Average
	✗ Product Specific

**Averaging:**

This EPD covers Schedule 40 and Schedule 80 cellular core rigid PVC conduit products manufactured by Atkore including straight conduit, elbows and sweeps. It is a product-average, manufacturer-average EPD, that is a declaration of an average product as an average from several of the manufacturer's plants. Product variations include differences in inner and outer diameter, wall thickness, length, bends, colors and labels. In particular, both Schedule 40 and Schedule 80 cellular core conduit are represented in this EPD.

Data tables, including product and packaging components, LCIA indicators, and other non-LCIA inventory metrics are reported for the production-weighted average of cellular core PVC products offered by Atkore. Values were normalized to the mass of conduit products and averaging was weighted by the total production mass of each product.

Results in this EPD are reported per declared unit (1 m) of Schedule 40 cellular core PVC conduit products of trade size 4". The data tables were calculated by multiplying the mass-normalized average values by the linear density of 4" Schedule 40 cellular core PVC conduit, as described in the PCR. Details on extrapolating results to other conduit types and trade sizes are provided in the section on Environmental Impacts.

Products in this category undergo primary manufacturing at two facilities belonging to Atkore. There are no secondary manufacturing facilities for PVC conduit. The entire production of Schedule 40 and Schedule 80 cellular core PVC conduit products manufactured during the reference year was included in the LCA study. This comprises all products manufactured across all relevant plants.

**Variation in GWP Result (Products):** -0.51% to +1.23%  
**Variation in GWP Result (Facilities):** -0.41% to +5.6%

## Plants

 **Atkore**  
6700 Enterprise Dr, Louisville, KY 40214, USA

 **Atkore**  
4950 McKennon Rd, Pendleton, OR 97801, USA

## Product Specifications

<b>Product SKU(s):</b>	4" Schedule 40 cellular core PVC rigid conduit
<b>Product Classification Codes:</b>	EC3 - UtilityPiping Masterformat - SECTION 26 05 33.13
<b>Outer diameter:</b>	1.14E+02 mm
<b>Inner diameter:</b>	1.01E+02 mm
<b>Wall thickness:</b>	6.02E+00 mm
<b>Material density:</b>	1135 kg/m <sup>3</sup>
<b>Mass per meter:</b>	2.49E+00 kg
<b>Performance standards:</b>	UL Std 651, NEMA Std TC 2, CSA Std C22.2 No. 211.2

## Material Composition

Material/Component Category	Origin	% Mass
PVC resin	None	82.41
Calcium carbonate	None	11.9
Additives	None	5.69

Packaging Material	Origin	kg Mass
Lumber	None	3.03E-03
PET banding	None	1.54E-03

Biogenic Carbon Content	kg C per m of conduit product
Biogenic carbon content in product	None
Biogenic carbon content in accompanying packaging	0.0732

Hazardous Materials
No regulated hazardous or dangerous substances are included in this product.

## EPD Data Specificity

- Primary Data Year: 2021
- Manufacturing Specificity:
- Industry Average
  - Manufacturer Average
  - Facility Specific

## Software and LCI Data Sources

- LCA Software: SimaPro v. 9.5
- LCI Foreground Database(s): Ecoinvent v. 3.9.1 | Cut-off | DATASmart LCI Package v. 2021 | Cut-off
- LCI Background Database(s): Ecoinvent v. 3.9.1 | Cut-off | Ecoinvent v. 2 | Cut-off

## Renewable Electricity

Renewable electricity is used: No

## System Boundary

Production	A1	Raw material supply	✓
	A2	Transport	✓
	A3	Manufacturing	✓
Construction	A4	Transport to site	ND
	A5	Assembly / Install	ND
Use	B1	Use	ND
	B2	Maintenance	ND
	B3	Repair	ND
	B4	Replacement	ND
	B5	Refurbishment	ND
	B6	Operational Energy Use	ND
	B7	Operational Water Use	ND
End of Life	C1	Deconstruction	✓
	C2	Transport	✓
	C3	Waste Processing	✓
	C4	Disposal	✓
Benefits & Loads Beyond System Boundary	D	Recycling, Reuse Recovery Potential	✓

## Product Flow Diagram

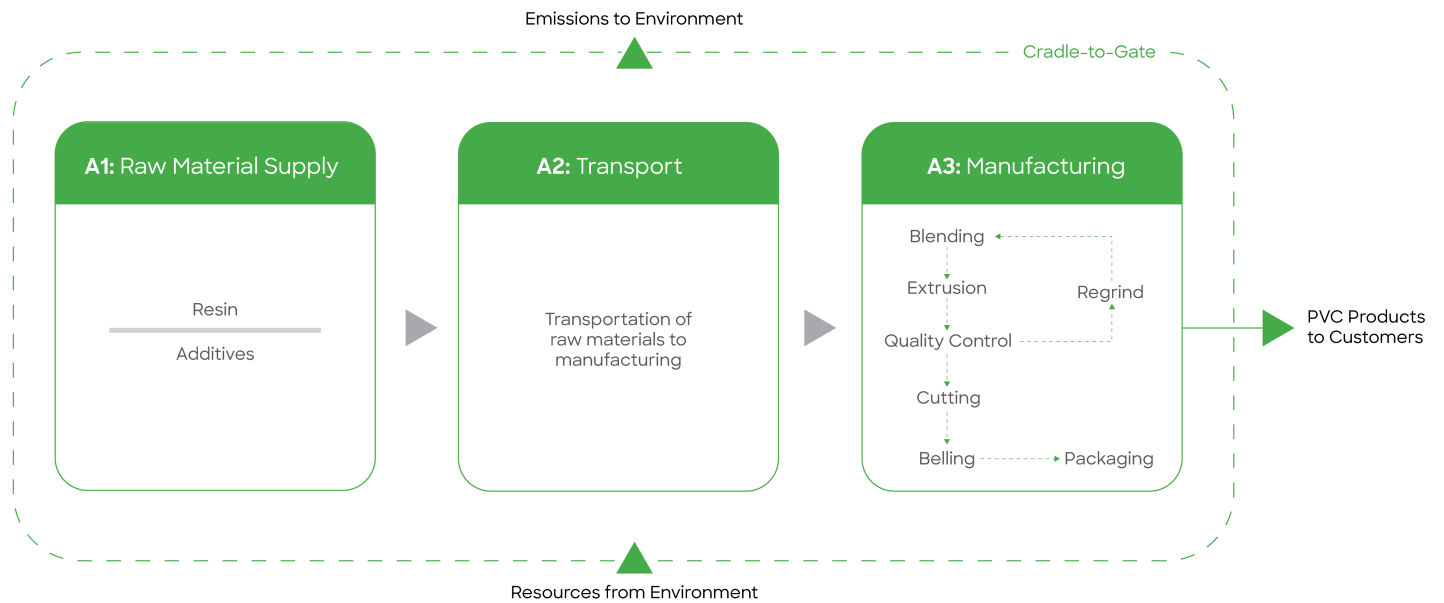

## Life Cycle Module Descriptions

### A1, extraction and upstream production

The information module “extraction and upstream production” covers raw material extraction and processing and processing of secondary material input (e.g. recycling processes). This is inclusive of generation of electricity, steam and heat from energy resources used for extraction and processing of raw materials, including their extraction, refining and transport.

In PVC conduit manufacturing, A1 includes all upstream impacts associated with the production of raw materials used, including PVC resin, calcium carbonate and additives.

### A2, transport to factory

The information module “transport to factory” covers transport of raw materials and other inputs from the supplier to the factory. Primary data was collected on transport distances and modes for this project. Where more than one supplier provided identical raw materials, a mass-weighted average distance was determined per mode. Average distances apply to the entire quantity of supplied materials, inclusive of any excess weight required to account for yield losses.

Impacts from the A2 stage are driven by the transport of the major components of PVC conduit manufacturing by weight. These are PVC resin with an average distance of 25 kilometers by truck and 3340 kilometers by rail and calcium carbonate with an average distance of 1360 kilometers by truck.

### A3, manufacturing

The information module “manufacturing” includes:

- production of ancillary materials or pre-products
- generation of electricity, steam and heat from primary energy resources used in manufacturing, including their extraction, refining and transport
- manufacturing of products and co-products, including their extraction, manufacturing and transport
- manufacturing of packaging, including their extraction, manufacturing and transport
- waste management from manufacturing packaging and manufacturing wastage including transport up to the recycler or disposal

Manufacturing of PVC rigid conduit products includes several processing steps:

1. PVC resin is blended with additives and stored in holding silos.



2. This mixture is fed into the extruder lines for pipe forming. Solid skins are co-extruded with a PVC core which has been processed in a way that creates an expanded cellular structure.
3. The extruded conduit is cooled with water and air.
4. Conduit is assessed for quality and off-spec parts are sent to be ground and recycled into new product.
5. The on-spec pipe is cut to length.
6. Conduit may receive additional processing such as belling of the ends or bending into elbows.
7. The finished product is strapped together in bundles with polyester strapping and wooden frames. The packages are stacked for storage prior to shipment.
8. 100% of scrap produced at factories is recycled.

## LCA Discussion

### Allocation Procedure

The inputs and outputs to the manufacturing plant are allocated per the stepwise method detailed in ISO 21930, Section 7.2.4, 7.2.5, and 7.2.6. Most plant inputs and outputs are assigned across total production (inclusive of cellular core PVC conduit products and other products) using mass-based allocation. Subdivision for product and packaging raw material inputs and scrap amounts was made possible through product bills of materials (BOMs). No co-products are generated in conduit manufacturing requiring allocation.

This study uses the cut-off approach method for recycling. According to this approach, the first life of a material bears the environmental burdens of its production (e.g., raw material extraction and processing) and the second life (e.g., scrap input) bears the burdens of refurbishment (e.g., collection and refining of scrap). The burdens from waste treatment are taken on by the next life of the product and not included in this study. Potential environmental benefits and burdens related to recycled materials are addressed in information module D.

### Cut-off Procedure

For the processes within the system boundary, all energy and material flows were included in the model. No known flows were excluded. All upstream and downstream activities were included using a combination of primary and secondary data. While the majority of inventory data were sourced from primary resources, representative proxies were used to close gaps in the absence of primary data.

### Data Quality Discussion

Foreground data were sourced from primary information provided by the Atkore and suppliers and has been reviewed by TrueNorth Collective to ensure precision and completeness. In order to balance out seasonal variations, operations data over a 12-month period, corresponding to the 2021 calendar year, was used to represent production activities. In addition, key model inputs such as mass balance, energy balance and emission inventory were reviewed by the Parallel and TrueNorth Collective teams. As all facilities involved in cellular core PVC conduit manufacturing were involved in this study, full representativeness of primary data was achieved in terms of geography, technology and production scale.

Ecoinvent v3.9.1 was used as the main database for background data. This version was published in 2023. Ecoinvent is widely used in research and industry to support life cycle assessment practices. Each version of this database goes through thorough review process and documentation of precision and completeness is available by the provider. DATASMART v2021 was used for US state specific manufacturing electricity. DATASMART is based on the US electricity grid in 2018. Both ecoinvent and DATASMART use the cut-off approach to allocation of materials for recycling.

Assessment of data quality, representativeness, and potential sources of uncertainty is performed using the Enhanced Pedigree Matrix proposed in the guidance for "Assessing Data Quality of Background Life Cycle Inventory (LCI) Datasets" published by the ACLCA in 2022. No major concerns were found to exist regarding data quality. Minor data gaps in packaging quantities and supplier transportation distances were resolved using estimates from related flows or expert judgement. Secondary data were assessed and deemed to be adequate for temporal, geographical and technological representativeness. Per the PCR, the background process chosen to represent PVC resin was based on the most recent American Chemistry Council report, which comprises PVC production data from plants based in the United States.

## Results

### Environmental Impact Assessment Results

#### TRACI 2.1

per 1 m of conduit product.

LCIA results are relative expressions and do not predict impacts on category endpoints, the exceeding of thresholds, safety margins or risks.

Impact Category	Method	Unit	A1	A2	A3	A1A2A3	C1	C2	C3	C4	D
GWP-total	TRACI 2.1	kg CO2 eq	5.73e+0	5.62e-1	5.41e-1	6.83e+0	0	3.82e-2	0	1.84e-1	0
ODP	TRACI 2.1	kg CFC 11 eq	8.18e-7	8.67e-9	2.66e-8	8.53e-7	0	6.50e-10	0	7.63e-10	0
AP	TRACI 2.1	kg SO2 eq	1.72e-2	4.38e-3	1.40e-3	2.30e-2	0	1.63e-4	0	5.72e-4	0
EP	TRACI 2.1	kg N eq	8.31e-3	7.57e-4	7.39e-4	9.81e-3	0	3.68e-5	0	1.98e-2	0
POCP	TRACI 2.1	kg O3 eq	2.10e-1	1.29e-1	1.55e-2	3.54e-1	0	4.25e-3	0	4.84e-3	0

**Abbreviations:**

GWP = Global Warming Potential, 100 years (may also be denoted as GWP-total, GWP-fossil (fossil fuels), GWP-biogenic (biogenic sources), GWP-luluc (land use and land use change)), ODP = Ozone Depletion Potential, AP = Acidification Potential, EP = Eutrophication Potential, SFP = Smog Formation Potential, POCP = Photochemical oxidant creation potential, ADP-Fossil = Abiotic depletion potential for fossil resources, ADP-Minerals&Metals = Abiotic depletion potential for non-fossil resources, WDP = Water deprivation potential, PM = Particulate Matter Emissions, IRP = Ionizing radiation, human health, ETP-fw = Eco-toxicity (freshwater), HTP-c = Human toxicity (cancer), HTP-nc = Human toxicity (non-cancer), SQP = Soil quality index.

The minimum system boundary per the PCR is cradle-to-gate with modules A1-A3, covering supplied raw materials (A1), transport from suppliers to Atkore (A2), and production of manufactured products (A3). Additionally, for conduit products which are not buried or encased in concrete, the end-of-life stage should be declared, encompassing modules C1 (deconstruction), C2 (transport), C3 (waste processing), and C4 (disposal). Module D must also be declared, specifying potential loads and benefits of secondary material, secondary fuel or recovered energy leaving the product system based on scenarios.

The conduit products referenced in this EPD may be used in applications where they are buried or encased in concrete but may also be used for other applications. A cradle-to-gate with end-of-life system boundary was thus adopted for the study. In cases where the user or reader wishes to apply the findings to a buried/encased application, they may leverage the cradle-to-gate results.

Comparisons cannot be made between product-specific or industry average EPDs at the design stage of a project, before a building has been specified. Comparisons may be made between product-specific or industry average EPDs at the time of product purchase when product performance and specifications have been established and serve as a functional unit for comparison. Environmental impact results shall be converted to a functional unit basis before any comparison is attempted. Any comparison of EPDs shall be subject to the requirements of ISO 21930 or EN 15804. EPDs are not comparative assertions and are either not comparable or have limited comparability when they have different system boundaries. EPDs are not comparative assertions and are either not comparable or have limited comparability when they have different system boundaries, are based on different product category rules or are missing relevant environmental impacts. Such comparison can be inaccurate, and could lead to erroneous selection of materials or products which are higher-impact, at least in some impact categories.

**Resource Use Indicators**  
per 1 m of conduit product.

Indicator	Unit	A1	A2	A3	A1A2A3	C1	C2	C3	C4	D
RPRE	MJ, LHV	1.67e+0	1.65e-1	3.81e+0	5.64e+0	0	7.16e-3	0	1.15e-2	0
RPRM	MJ, LHV	0	0	6.66e-1	6.66e-1	0	0	0	0	0
RPRT	MJ, LHV	1.67e+0	1.65e-1	4.48e+0	6.32e+0	0	7.16e-3	0	1.15e-2	0
NRPRE	MJ, LHV	8.30e+1	7.75e+0	7.52e+0	9.83e+1	0	5.79e-1	0	6.78e-1	0
NRPRM	MJ, LHV	4.42e+1	0	3.28e-2	4.42e+1	0	0	0	0	0
NRPRT	MJ, LHV	1.27e+2	7.75e+0	7.56e+0	1.42e+2	0	5.79e-1	0	6.78e-1	0
SM	kg	0	0	0	0	0	0	0	0	0
RSF	MJ, LHV	0	0	0	0	0	0	0	0	0
NRSF	MJ, LHV	0	0	0	0	0	0	0	0	0
RE	MJ, LHV	0	0	0	0	0	0	0	0	0
ADPF	MJ, LHV	1.58e+1	9.75e-1	9.20e-1	1.77e+1	0	7.63e-2	0	8.80e-2	0
FW	m <sup>3</sup>	5.92e-2	1.24e-3	2.95e-3	6.34e-2	0	8.06e-5	0	6.55e-4	0

Abbreviations:

RPRE or PERE = Renewable primary resources used as energy carrier (fuel), RPRM or PERM = Renewable primary resources with energy content used as material, RPRT or PERT = Total use of renewable primary resources with energy content, NRPRE or PENRE = Non-renewable primary resources used as an energy carrier (fuel), NRPRM or PENRM = Non-renewable primary resources with energy content used as material, NRPRT or PENRT = Total non-renewable primary resources with energy content, SM: Secondary materials, RSF = Renewable secondary fuels, NRSF = Non-renewable secondary fuels, RE = Recovered energy, ADPF = Abiotic depletion potential, FW = Use of net freshwater resources, VOCs = Volatile Organic Compounds.

**Waste and Output Flow Indicators**  
per 1 m of conduit product.

Indicator	Unit	A1	A2	A3	A1A2A3	C1	C2	C3	C4	D
HWD	kg	0	0	0	0	0	0	0	0	0
NHWD	kg	0	0	0	0	0	0	0	2.49e+0	0
HLRW	kg	0	0	0	0	0	0	0	0	0
ILLRW	kg	0	0	0	0	0	0	0	0	0
CRU	kg	0	0	0	0	0	0	0	0	0
MFR	kg	0	0	0	0	0	0	0	0	0
MER	kg	0	0	0	0	0	0	0	0	0
EE	MJ, LHV	0	0	0	0	0	0	0	0	0

Abbreviations:

HWD = Hazardous waste disposed, NHWD = Non-hazardous waste disposed, RWD = Radioactive waste disposed, HLRW = High-level radioactive waste, ILLRW = Intermediate- and low-level radioactive waste, CRU = Components for re-use, MFR or MR = Materials for recycling, MER = Materials for energy recovery, MNER = Materials for incineration, no energy recovery, EE or EEE = Recovered energy exported from the product system, EET = Exported thermal energy.

## Carbon Emissions and Removals

per 1 m of conduit product.

Indicator	Unit	A1	A2	A3	A1A2A3	A5	C1	C2	C3	C4	D
BCRK	kg CO2	0	0	7.32e-2	7.32e-2	0	0	0	0	0	-1.46e-2
BCEK	kg CO2	0	0	0	0	5.83e-2	0	0	0	0	0

Abbreviations:

BCRP = Biogenic Carbon Removal from Product, BCEP = Biogenic Carbon Emission from Product, BCRK = Biogenic Carbon Removal from Packaging, BCEK = Biogenic Carbon Emission from Packaging, BCEW = Biogenic Carbon Emission from Combustion of Waste from Renewable Sources Used in Production Processes, CCE = Calcination Carbon Emissions, CCR = Carbonation Carbon Removals, CWNR = Carbon Emissions from Combustion of Waste from Non-Renewable Sources used in Production Processes, GWP-luc = Carbon Emissions from Land-use Change.

The biogenic removals and emissions are determined following the ACLCA Guidance to Calculating Non-LCIA Inventory Metrics in Accordance with ISO 21930:2017.

Biogenic carbon removals in information module A3 stem from the supply of lumber used to secure conduit in "frames". Assumed recycling rates of this packaging was 20%, taken from the PCR Part A. Emissions in module A5 come from the proportional part of the frames which is landfilled and/or incinerated. The negative removal in module D shows the biogenic carbon leaving the system through recycling. There is a net zero flow of biogenic carbon across all information modules: all biogenic carbon which enters the system in A3 is either emitted in A5 or exits the system in module D.

## Impact Scaling Factors

Trade Size	Outer Diameter (mm)	Inner Diameter (mm)	Minimum Wall Thickness (mm)	Linear Density (kg per m)	Scaling Factor (per m)	Scaling Factor (per 10 ft)
Schedule 40 3"	8.89E+01	7.64E+01	5.49E+00	1.85E+00	7.43E-01	2.26E+00
Schedule 40 3-1/2"	1.02E+02	8.85E+01	5.74E+00	2.28E+00	9.16E-01	2.79E+00
Schedule 40 4"	1.14E+02	1.01E+02	6.02E+00	2.49E+00	1.00E+00	3.05E+00
Schedule 40 5"	1.41E+02	1.26E+02	6.55E+00	5.67E+00	2.28E+00	4.22E+00
Schedule 40 6"	1.68E+02	1.52E+02	7.11E+00	4.71E+00	1.89E+00	5.77E+00
Schedule 80 3"	8.89E+01	7.16E+01	7.62E+00	2.45E+00	9.82E-01	2.99E+00
Schedule 80 4"	1.14E+02	9.49E+01	9.58E+00	3.52E+00	1.41E+00	4.31E+00
Schedule 80 5"	1.41E+02	1.20E+02	9.53E+00	4.46E+00	1.79E+00	5.46E+00
Schedule 80 6"	1.68E+02	1.43E+02	1.10E+01	6.68E+00	2.68E+00	8.18E+00

The results in this EPD are reported for 1 m (the declared unit) of 4" Schedule 40 cellular core rigid PVC conduit (the reference product). Environmental impacts of other types and trades sizes (product-specific results) can be calculated using the equation  $Results\_PS = Results\_Ref \times Multiplier\_PS$  where Results\_PS is the product-specific result per declared unit, Results\_Ref is the result per declared unit of the reference product and Multiplier\_PS is the product-specific declared unit multiplier.

The impact scaling factor table provides the product-specific declared unit multipliers, Multiplier\_PS (marked as "Scaling Factor" in the table), which are calculated as (specific product's mass per declared unit)/(reference product's mass per declared unit), that is, the quotient between the linear density of a specific type and trade size and that of 4" Schedule 40 cellular core rigid PVC conduit. Scaling factors are also provided for calculating impacts per 10-foot section of conduit.

This calculation method can be used to derive a result for any or all declared indicators and for any reported life module(s). When using this equation, the EPD user defines which indicator and life cycle stage(s) they are using to calculate a product-specific result. The Results\_PS and Results\_Ref values must align with the same indicator and life cycle stage(s) included.

## Scenarios

### End of Life

C1 - C4 Modules

#### Collection Process

Collected with Mixed Construction Waste: 2.49 kg

#### Recovery

Landfill: 2.49 kg

#### Disposal

Product or Material for Final Disposal: 2.49 kg

Removals of Biogenic Carbon: 0.0732 kg CO<sub>2</sub>

#### Assumptions for scenario development:

C1, deconstruction/demolition includes dismantling or demolition, of the construction product from the construction works and the energy use for this, including initial on-site sorting of the materials. For conduit, removal at the end of life requires only human labor and does not contribute to lifetime environmental impacts.

C2, transportation to waste processing or disposal, includes the transportation of the discarded construction product as part of the waste processing, for example to a recycling site and transportation of waste, for example to final disposal. Per the PCR, transport was assumed to be 100 kilometers by truck.

C3, waste processing, which includes, for example collection of waste fractions from the deconstruction, recovery and waste processing of material flows resulting in materials for reuse, secondary materials, secondary fuels or export of recovered energy. As conduit is not recycled, the C3 modules is included but has zero impacts.

C4, disposal of waste which includes physical pre-treatment and management of the disposal site, including provision and transport of all materials, products and related energy and water use. Per the PCR, conduit was assumed to be landfilled at End of Life.

## Reuse, Recovery and / or Recycling Potentials & Relevant Scenario Information

D Module

#### Further assumptions for scenario development:

Module D information declares potential loads and benefits of secondary material, secondary fuel or recovered energy leaving the product system based on scenarios. The impacts associated with module D are calculated by identifying the point of substituted functional equivalence where the secondary material substitutes primary production and subtracting the impacts resulting from the substituted production of the product.

There are no flows of recovered materials into or out from the cellular core PVC conduit product system. Although PVC is recyclable, the PCR specifies a product recycling rate of 0% for "other materials", under which PVC is classified. In addition, biogenic carbon removals associated with packaging materials leaving the system boundary through recycling during A5 are declared in module D.

## Interpretation

The contribution analysis indicates that the majority of the potential impacts occur as a result of raw material supply (A1) with an important contribution coming also from supplier transport (A2) and manufacturing (A3). PVC resin is the main material contributing to impacts in A1. The exception is for the impact category "Eutrophication Potential", where direct emissions from landfilling the conduit at end of life (C4) is the major driver.

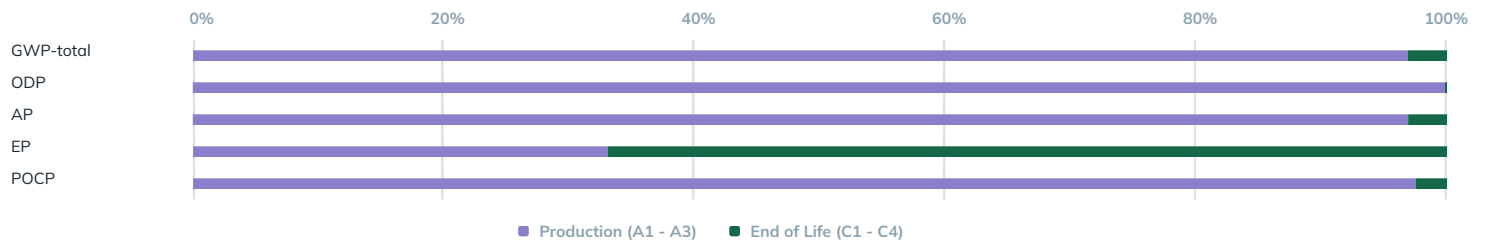

## Additional Environmental Information

Atkore PVC conduit does not contain any substances identified as hazardous according to the normative requirements in standards or regulations applicable in the markets where they are sold, and the additional standards listed in PCR Part A 8.4.1.

Atkore PVC conduit does not release any dangerous substances as classified by the standards listed in PCR Part A 8.4.1.

## Further Information

### Secondary data contributing >30% to disclosed environmental impact categories.

Component or Input	Dataset Used	Database
PVC Resin	Custom dataset modeled after the 2021 report, prepared by Franklin Associates, entitled Cradle-to-Gate Life Cycle Analysis of Polyvinyl (PVC) Resin	Custom
Electricity	Various state-specific grid mixes from DATAS-MART LCI Package	DATASMART v2021
Truck Transport	Transport, freight, lorry, unspecified {RoW}  market for transport, freight, lorry, unspecified   Cut-off, U	ecoinvent 3.9.1
Landfilling of PVC	Waste polyvinylchloride {RoW}  treatment of waste polyvinylchloride, sanitary landfill   Cut-off, U	ecoinvent 3.9.1

## References

- ACLCA. (2019). ACLCA Guidance to Calculating Non-LCIA Inventory Metrics in Accordance with ISO 21930:2017. ACLCA.
- Bare, J., Gloria, T., & Norris, G. (2006). Development of the Method and U.S. Normalization Database for Life Cycle Impact Assessment and Sustainability Metrics. Environmental Science & Technology .
- Bare, J., Norris, G., Pennington, D., & McKone, T. (2003). TRACI: The Tool for the Reduction and Assessment of Chemical and Other Environmental Impacts. Journal of Industrial Ecology .
- IPCC, I. P. (2013). IPCC Fifth Assessment report. The Physical Science Basis. Retrieved from <http://www.ipcc.ch/report/ar5/wg1/>.
- ISO. (2006). ISO 14025:2006: Environmental labels and declarations — Type III environmental declarations — Principles and procedures. International Organization for Standardization.
- ISO. (2006). ISO 14044:2006 Environmental management - Life cycle assessment - Requirements and guidelines. International organization for Standardization (ISO).

- ISO. (2006). ISO14040:2006/Amd 1:2020 -- Environmental management -- Life cycle assessment -- Principles and framework. International Organization for Standardization.
- ISO. (2014). ISO 14046:2014 Environmental management - Water footprint - Principles, requirements and guidelines.
- ISO 21930. (2017). Sustainability in buildings and civil engineering works — Core rules for environmental product declarations of construction products and services.
- Long Trail Sustainability. (2020). DATASMART LCI Package.
- Mukherjee, A., & Bhat, C. G. (2022). Assessing Data Quality of Background Life Cycle Inventory (LCI) Datasets. ACLCA.
- Smart EPD. (2024). Part A Product Category Rules for Building and Construction Products and Services (Smart EPD, Standard 1000, Version 1.01).
- Smart EPD. (2024). Part B Product Category Rules for Electrical and Telecommunications Conduit (Smart EPD, Standard 1000-001 Version 1.0).
- Weidema B P, B. C. (2013). Overview and methodology. Data quality guideline for the ecoinvent database version 3. St. Gallen: The ecoinvent Centre.



Allied Tube & Conduit ▲ AFC Cable Systems ▲ Heritage Plastics ▲ Unistrut  
Unistrut Construction ▲ Cope ▲ US Tray ▲ Calbrite ▲ Calbond ▲ Kaf-Tech  
Columbia-MBF ▲ Eastern Wire + Conduit ▲ ACS/Uni-Fab ▲ Cii  
Power-Strut ▲ Calconduit ▲ Razor Ribbon ▲ Calpipe Security  
Vergokan ▲ Flexicon ▲ Marco

## **Atkore**

16100 South Lathrop Avenue  
Harvey, IL 60426

**TOLL FREE / 800-882-5543**  
**FAX / 708-339-7814**

[atkore.com/power-strut](http://atkore.com/power-strut)

Want to join a company that helps you build  
the mindset, skill set and tool set for success?  
Visit us at [atkore.com/careers](http://atkore.com/careers)