

CABLE MANAGEMENT SOLUTIONS

Version 16

Alterations to this document by any agency other than Atkore International voids the certification.



Atkore[™]
Cope



Thomas Jefferson Cope founded T.J. Cope in Philadelphia, Pennsylvania in 1887. At that time, T.J. Cope's primary business was designing and manufacturing cable installation/pulling equipment for overhead and underground applications.

In 1948, T.J. Cope introduced the first modular Cable Tray System. The tray system was fabricated from sheet metal with the edges turned up forming a trough shape. This type of installation offered a more flexible and economical alternative to the traditional use of conduit.

In 1957, T.J. Cope was purchased by the Rome Cable Corporation, which in turn, was purchased by Alcoa in 1959. The Cyprus Mines Corporation purchased T. J. Cope six years later when the U. S. Justice Department forced Alcoa to divest its holdings of the Rome Cable Company.

T.J. Cope was merged into Allied Tube & Conduit Corporation in 1996. The Cope brand is owned by Allied Tube & Conduit Corporation and is part of the Electrical and Support Division. Allied Tube & Conduit Corporation is a world leading manufacturer of galvanized steel tubing, including electrical

conduit; its affiliate, AFC Cable Systems, provides AC/MC cable and flexible conduits; and its other affiliate, Unistrut International Corporation, provides Power-Strut and Unistrut metal framing systems. Allied Tube & Conduit Corporation, a part of Atkore International, serves the electrical, mechanical, and construction markets worldwide.

Our mission is to be our customers' first choice by providing unmatched quality, delivery, and value.

Headquarters:

Atkore
16100 S Lathrop
Harvey, IL 60426
Tel: 708-339-1610
Toll Free: 800-882-5543





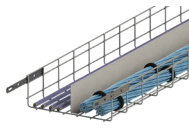
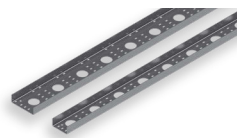

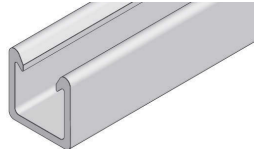
Manufacturing:

Atkore
11500 Norcom Rd,
Philadelphia, PA 19154

Atkore
11539 North Houston
Rosslyn Road
Houston, TX 77088

Atkore
560 Wharton Circle,
Suite E
Atlanta, GA 30336



Features & Technical Data.....	5	
C-Channel Swage Ladder.....	11	
I-Beam Ladder.....	57	
Trof.....	83	
Eagle Basket.....	125	
Channel.....	157	
Glas.....	167	
Aickinstrut.....	213	
Reference Data.....	257	

FEATURES

SWAGE

I-BEAM

TROF

EAGLE BASKET

CHANNEL

GLAS

AICKINSTRUT

DATA

Cope Cable Tray Solutions for your Infrastructure Requirements

This complete catalog is designed for ease of use and to provide the basic information needed to select the proper cable tray system for your needs.

The first section of the catalog provides comprehensive product information, definitions, and technical data needed to select the proper tray.

The second section provides industry standards and guidelines for the manufacture and installation of cable tray.



Cope aluminum and steel Swaged C-Channel ladder trays use our swaging system of rung attachment. This system of attachment provides a very rigid tray without welding that is easy to handle and install. The flange out design provides the maximum access to your cables, even in narrow or divided cable trays.

Cope's aluminum I-Beam tray provides a heavy duty welded cable tray for clients requiring I-Beam side rails. It is perfect for long span locations, and offers best in class loading properties.

Cope's solid or ventilated bottom Trof provides the ultimate in cable support for your small diameter, flexible cable. With 1" ribs located every 2" on center, drooping of cable is virtually eliminated.

Cope Eagle Basket provides the superior flexibility and ease of installation required by datacom installations. The exclusive Quick-Latch system speeds cable tray installation.

Cope's Channel provides an excellent support system for those applications where only a few cables are needed. It can also be used for separation of services in ladder or trof trays.

Cope Glas™ and Aickinstrut fiberglass framing systems provide the answer to many adverse environments. Life cycle costs, long span capability and easy field modification make Cope Glas™ and Aickinstrut an ideal choice for industrial, chemical, and petro-chemical facilities.

Our Sales Team is available to assist with questions about application, installation, and availability of our products.

Thank you for considering Cope for your cable tray requirements.



Product Features

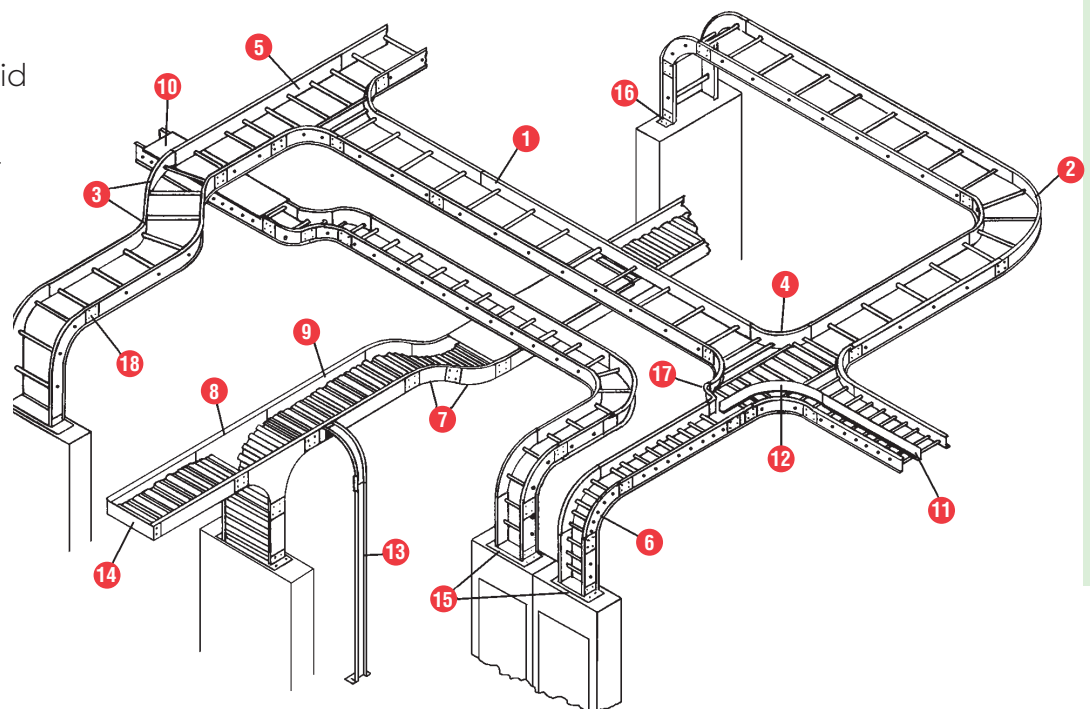
Selecting a Cope Cable Tray System

A number of factors must be considered when selecting the proper cable tray system and planning the installation:

- Material and Finish
- Types of Cable Tray
- NEMA Class
- Cavity Size – Load/Depth/Width of Tray
- Length of Straight Sections
- Rung Spacing
- Radius of Fittings
- Cable Tray Support Locations
- Electrical Grounding

Cable Tray System Drawing Legend

- | | |
|---|-------------------------------------|
| 1. Straight Section, Ladder | 12. Barrier Strip |
| 2. Horizontal Elbow, 90°, Ladder Type | Flexible-Horizontal Fitting |
| 3. Horizontal Elbow, 30°, 45°, or 60° | 13. Straight Section, Channel |
| 4. Horizontal Cross, Ladder Type | 14. Blind End |
| 5. Horizontal Tee, Ladder Type | 15. Box Connector |
| 6. Vertical Elbow, Outside, 90° | 16. Angle Connector |
| 7. Vertical Elbow, Outside & Inside, 30°, 45°, or 60° | 17. Reducing Connector |
| 8. Vertical Tee, Solid Bottom Trof Type | 18. Universal Curvilinear Connector |
| 9. Straight Section, Solid Bottom Trof | |
| 10. Flanged Solid Cover | |
| 11. Barrier Strip–Straight Section | |

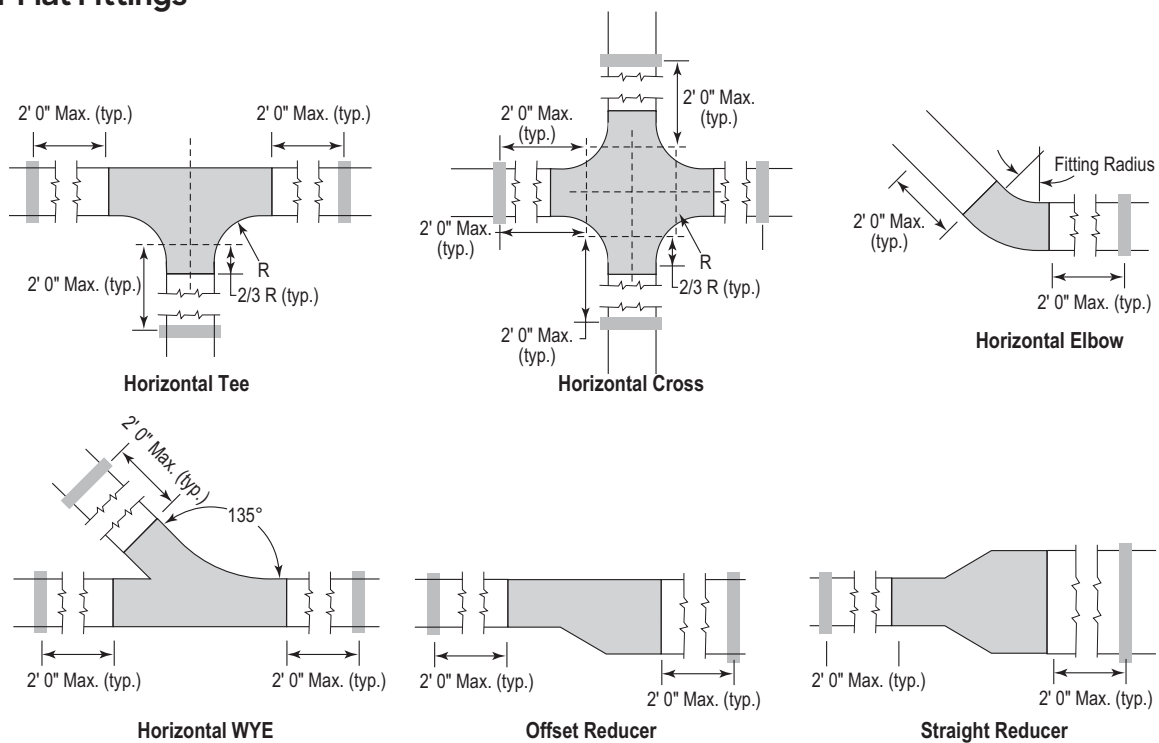


Cable Tray Fittings

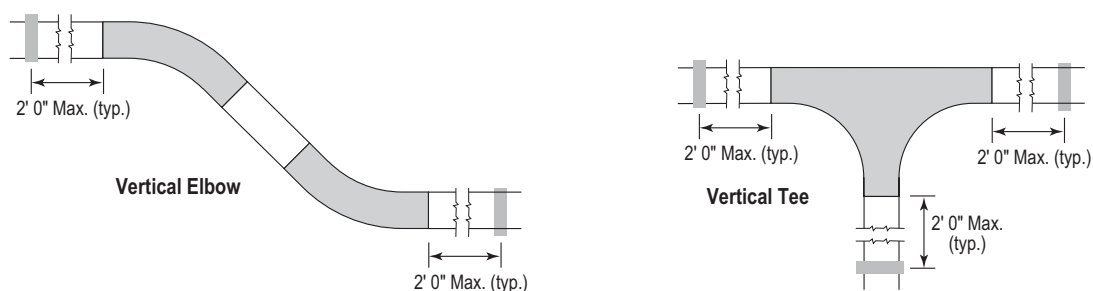
Fittings are used to change the size and/or direction of the cable tray. A wide variety of standard fittings are offered to simplify installation of a tray system. Horizontal and vertical bends are offered for each tray width and with angles of 30°, 45°, 60°, or 90°. The radius of the bend, whether horizontal or vertical, can be 12", 24", 36", or even greater on a custom basis. Specification of the radius of the bend involves a trade-off between available space, minimum bending radius of cables, ease of cable pulling, and cost. The most common radius is 24". Fittings are not subject to NEMA/CSA load ratings and the diagrams below illustrate how the tray should be supported near the fittings.

When a standard angle will not work, field fittings or adjustable elbows can be used. Refer to NEMA VE2 Installation Guidelines for suggested support locations for these situations.

Support for Flat Fittings



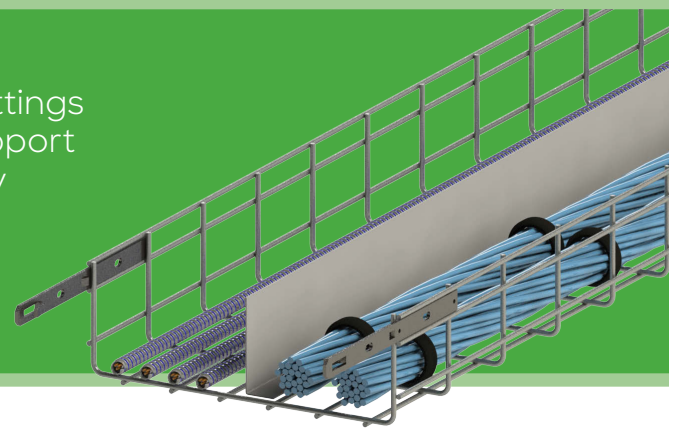
Support for Vertical Fittings



Cable Tray 101

Types Of Cable Tray

Any assembly of cable tray straight sections, fittings and accessories that form a rigid system to support cables is a cable tray. The different types of tray designs are described below.



C-Channel Swage Ladder

Two aluminum or steel C-Channel profile side rails with transverse ladder rungs; provides the most rigid ladder tray system. Ideal for high vibration environments.

I-Beam Ladder

Two extruded aluminum I-Beam profile side rails with transverse welded rungs. Best in class loading capacities provide long support span capability and versatility.

Ventilated Trof

Two steel C-Channel flange in and welded corrugated bottom construction. Trof cable trays are the best choice for smaller cables. Ventilated trofs offer some airflow while completely eliminating cable sagging.

Solid Trof

Two steel C-Channel flange in and welded solid bottom construction. Solid bottom cable trays completely eliminate cable sagging and offer the most protection for the cables.

Eagle Basket

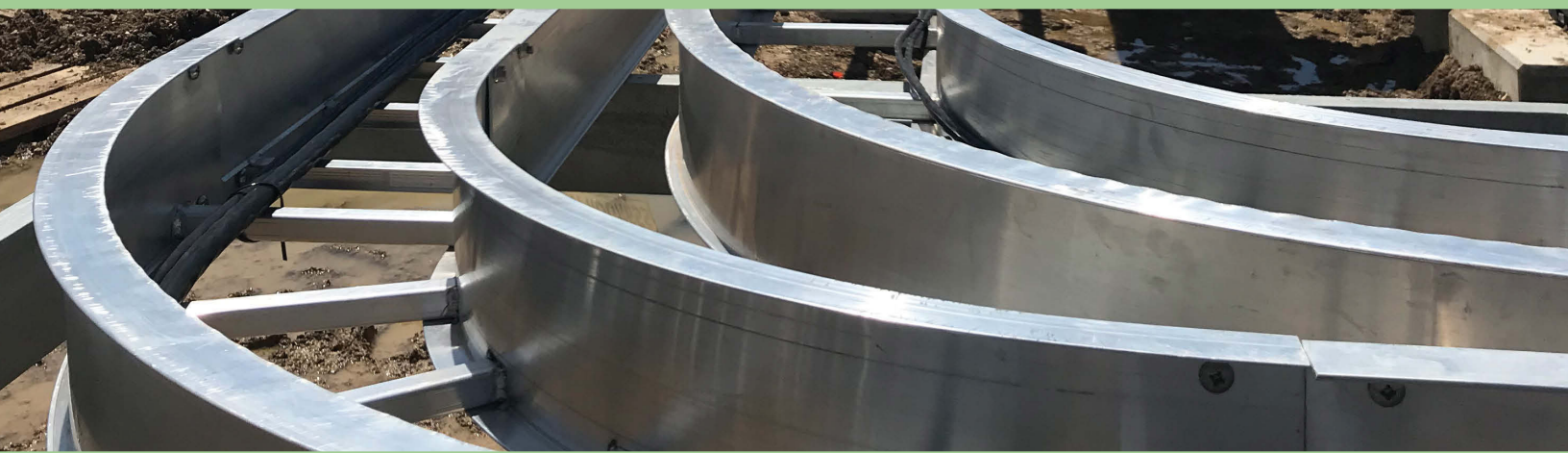
Provides the superior flexibility and ease of installation require by power and data-com installations. The exclusive Quick-Latch system provides industry leading installation time. Offered in a variety of materials and finishes, the 2"x4" wire mesh grid construction allows for maximum airflow.

Cable Channel

Metal U-Shaped construction available with ventilated or solid bottom. Ideal for branch power circuits, control, signal, and tubing systems.

Cope-Glas™

Fiberglass cable tray provides the answer to many adverse environments. Life cycle costs, long span capability and easy field modification make Cope-Glas™ an ideal choice for industrial, chemical, and petro-chemical facilities.



Materials and Finish

The material selection is based on the environmental conditions and economic considerations for the project.

Aluminum

Aluminum material in accordance with AA-6063-T6. Aluminum trays are suitable for most outdoor applications and offer reductions in total installed costs.

Steel - Pre-Galvanized

Hot Dip Mill-Galvanized steel (ASTM-A-653-G90 CS) is zinc coated by a hot dip process. Steel strip from a coil is fed through a continuous zinc coater which cleans, fluxes and coats the steel with molten zinc. After cooling, the steel is recoiled. The pre-galvanized coating provides a total weight of 0.90 oz. of zinc for both sides of one square foot of material.

Mill-galvanized ladder is made of pre-galvanized steel and generally used indoors or in locations not exposed to the elements or corrosives.

Steel - Hot Dip Galvanized after Fabrication

In hot dip galvanizing after fabrication (HDGAF), the finished part is immersed in a bath of molten zinc (ASTM 123). This method results in complete zinc coverage and a thicker coating than pre-galvanized or electro-plated steel.

The zinc coating is typically 2.6 mils or 1.5 oz./sq. ft. of surface area.

This is the coating of choice for applications where protection from severe corrosion is a design factor.

Stainless Steel

Type 304 and Type 316 stainless steel material in accordance with ASTM-A-240.

Fiberglass

For extremely corrosive areas, Cope offers the most complete line of fiberglass cable trays available. In addition, a full line of Aickinstrut and channel fiberglass products is available to support your full raceway installation.

Complementary Products

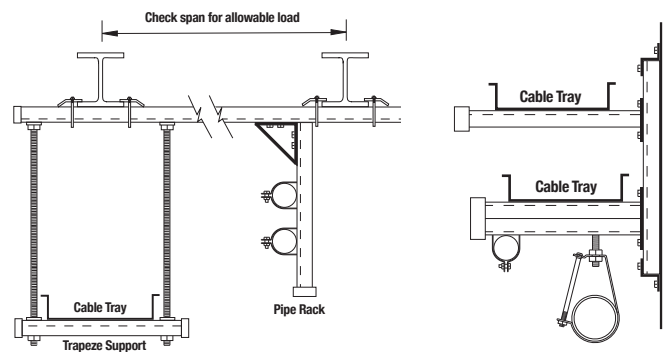
Building Better Together

Cope is a part of Atkore, a company focused on providing solutions that power and protect the world. Look to our full portfolio of nearly century-old trusted sub-brands as solutions for your construction needs including:

Metal Framing & Trapezes

With industry leading sub-brands such as Unistrut® and Powerstrut®, we lead the way with the most comprehensive line of channels and fittings, along with a complete line of hangers, pipe clamps, concrete inserts, and accessories, in a variety of finishes and materials. Elevate your cable management system with trapezes customized to your application. Backed by a worldwide network of engineering and distribution centers, Atkore is the number one choice for all your metal framing and cable management securing needs.

Visit www.unistrut.us or www.power-strut.com for more info.

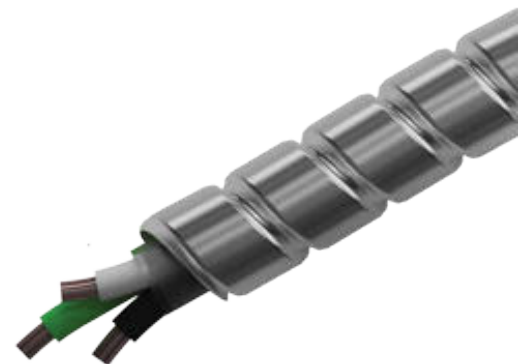


MC Cable & Flexible Conduit

Couple your cable management solutions with our armored cables and flexible conduits under the trusted AFC Cable Systems® sub-brand. Demonstrating reliability since 1926, our cable solutions include

- Aluminum MC Cable
- Steel MC Cable
- Aluminum AC Cable
- Steel AC Cable
- Fire Alarm Cable
- Liquid Tight Flexible Conduit
- Reduced Wall Conduit
- Aluminum Flexible Conduit

Visit www.afcweb.com or www.kaf-tech.com for more info.



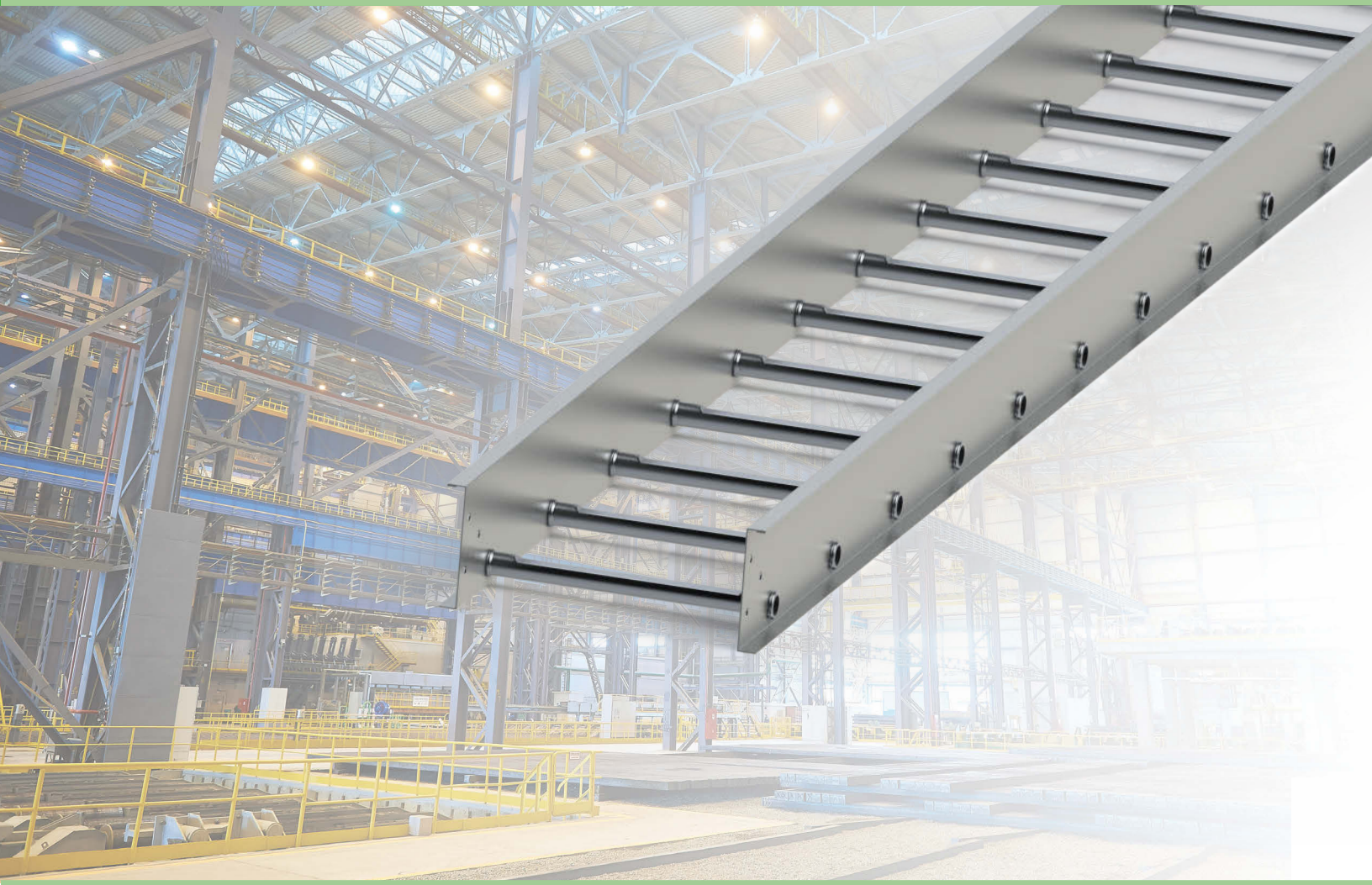
Quotation Check List for Cable Trays

Name:			Date:						
Contractor:			Location:						
Distributor:									
Contact:									
Email/Phone:									
TRAY TYPE:	<input type="checkbox"/> Ladder	<input type="checkbox"/> Marine Rung	<input type="checkbox"/> Vent Trof	<input type="checkbox"/> Solid Trof					
	<input type="checkbox"/> Channel	<input type="checkbox"/> Wire Basket	<input type="checkbox"/> I-Beam						
TRAY MATERIAL:	<input type="checkbox"/> Aluminum	<input type="checkbox"/> Steel, Pre-Galvanized	<input type="checkbox"/> Steel, HDGAF	Other,					
	<input type="checkbox"/> 304 Stainless Steel	<input type="checkbox"/> 316 Stainless Steel	<input type="checkbox"/> Fiberglass	<input type="checkbox"/> _____					
TRAY MATERIAL: (Fiberglass Only)	<input type="checkbox"/> Polyester	<input type="checkbox"/> Vinyl Ester							
TRAY LENGTH:	<input type="checkbox"/> 10'	<input type="checkbox"/> 12'	<input type="checkbox"/> 20'	<input type="checkbox"/> 24'	<input type="checkbox"/> 30'				
TRAY WIDTH:	<input type="checkbox"/> 6"	<input type="checkbox"/> 9"	<input type="checkbox"/> 12"	<input type="checkbox"/> 18"					
	<input type="checkbox"/> 24"	<input type="checkbox"/> 30"	<input type="checkbox"/> 36"	<input type="checkbox"/> 42" or <input type="checkbox"/> 48" Note: Ladder Tray Only, not NEMA Standard					
TRAY WIDTH: (Wire basket Only)	<input type="checkbox"/> 2"	<input type="checkbox"/> 4"	<input type="checkbox"/> 6"	<input type="checkbox"/> 8"	<input type="checkbox"/> 12"	<input type="checkbox"/> 16"	<input type="checkbox"/> 18"	<input type="checkbox"/> 20"	<input type="checkbox"/> 24"
RUNG SPACING:	<input type="checkbox"/> 6"	<input type="checkbox"/> 9"	<input type="checkbox"/> 12"	<input type="checkbox"/> 18"					
LOAD DEPTH:	<input type="checkbox"/> 2"	<input type="checkbox"/> 3"	<input type="checkbox"/> 4"	<input type="checkbox"/> 5"	<input type="checkbox"/> 6"				
FITTING RADIUS:	<input type="checkbox"/> 12"	<input type="checkbox"/> 24"	<input type="checkbox"/> 36"						
STRUCTURAL REQUIREMENTS: (NEMA CLASS) OR,	<input type="checkbox"/> 8A	<input type="checkbox"/> 8B	<input type="checkbox"/> 8C						
	<input type="checkbox"/> 12A	<input type="checkbox"/> 12B	<input type="checkbox"/> 12C						
	<input type="checkbox"/> 16A	<input type="checkbox"/> 16B	<input type="checkbox"/> 16C						
	<input type="checkbox"/> 20A	<input type="checkbox"/> 20B	<input type="checkbox"/> 20C	<input type="checkbox"/> 20C+					
CABLE WEIGHT SUPPORT SPAN									
SPECIAL REQUIREMENTS:									
DELIVERY REQUIREMENTS:									

If you need assistance, contact one of our Technical Product Engineers who will be happy to help at CopeMarketing@atkore.com



C-Channel Swage Ladder



**Cable Ladder System for Power, Control,
Instrumentation Cable & Pneumatic Tubing**



General & Technical Information

Pictorial Index 13
 Selection Chart: Cope Ladder - Aluminum 14
 Selection Chart: Cope Ladder - Steel 16
 Overview 18
 Part Number Overview 21
 Electrical Grounding Chart & Ladder Specs 24
 CSA Selection Chart: Steel 26
 Fitting System..... 27

Cope Ladder Fittings

Horizontal Elbows
 90° 28
 60° 28
 45° 29
 30° 29
 Horizontal Tee 30
 Horizontal Cross 31
 Horizontal Tapped Tee 32
 Horizontal Tapped Cross 34
 Left and Right Hand Reducers 36
 Straight Reducer 37
 45° Y Branch (Left & Right) 38
 Adjustable Elbow 38
 Vertical Elbows
 90° & 60° Vertical Elbows (Inside and Outside) 39
 45° & 30° Vertical Elbows (Inside and Outside) 40
 90° Vertical Cable Support Elbow 41
 Vertical Tee 41

Connectors & Hardware

Universal Curvilinear Connector, Expansion, Mid-Span Splice & Expansion Plate,
 Horiz. and Vert. Adjustable, Stepdown and 90° Connector 42
 Reducing Connector & General Hardware..... 43

Covers

Covers 44
 Cover Accessories (Hold down clamps, elevated and peaked cover connectors)... 46

Accessories

Box Connector, Drop Out, Blind End, Bonding Jumper, Ground Clamp 48
 Ground Cable Retainer Clamp, Conduit Clamp, Wall Sleeve 49
 Barrier Strips and Barrier Strip Clamps 50
 Hold Down Clamp and Expansion Guide, Seismic Hold Down 52
 Cable Clamp, Support Brackets, Tray Hangers, Trapeze Supports 53

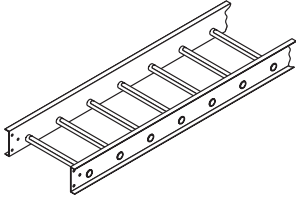


Pictorial Index

Ladder Pictorial Index

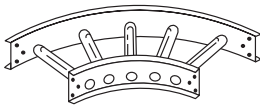
Straight Length

Page 22



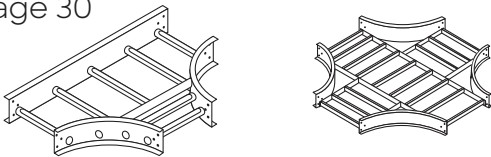
Horizontal Elbows

Page 28



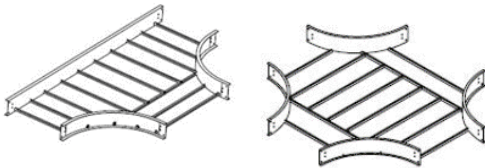
Horizontal Tee & Cross

Page 30



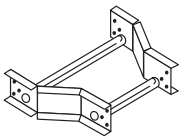
Horizontal Tapped Tee & Cross

Page 32



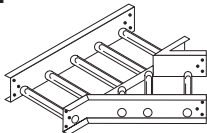
Reducers

Page 36



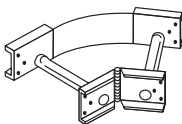
45° Y Branch

Page 38



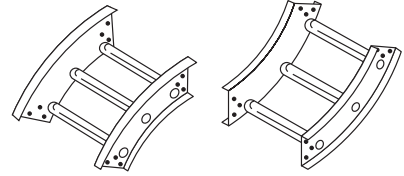
Adjustable Elbows

Page 38



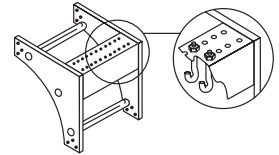
Vertical Elbows

Page 39



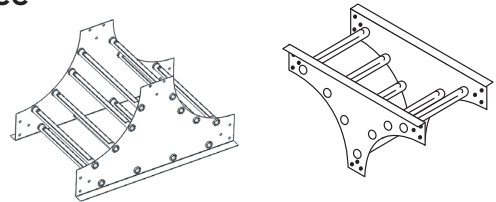
90° Vertical Cable Support Elbow

Page 41



Vertical Tee

Page 41



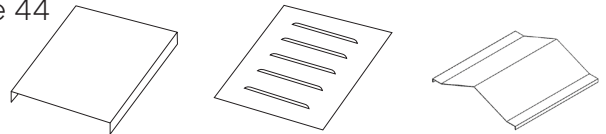
Connectors

Page 42



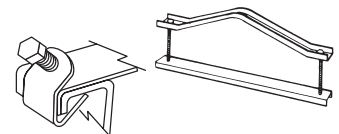
Covers

Page 44



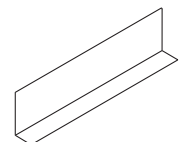
Cover Accessories

Page 46



Accessories

Page 48



FEATURES

SWAGE

I-BEAM

TROF

EAGLE BASKET

CHANNEL

GLAS

AICKINSTRUT

DATA

Aluminum Tray

NEMA Standard VE-1 Load/ Span Class	NEMA Ld/Span	System Number	Systems Certified by CSA	Actual Load Depth		Side Rail Height		Flange Width	1 Sect. Mod. of 2 Rails	Moment of Inertia for 2 Rails Ix	Min X-Sect. Area of 2 Rails per NEC 392.7
8A-12A	50 lb./ft. 12' span	RT38	1B38	3"	(76mm)	4 ¼"	(108mm)	13/16"	0.898"	1.822"	.60"
		RT48	1B48	4"	(102mm)	5 ¼"	(133mm)	13/16"	1.142"	2.872"	.60"
		RT58	—	5"	(127mm)	6 ¼"	(159mm)	13/16"	1.614"	4.720"	1.00"
		RT68	—	6"	(152mm)	7 ¼"	(184mm)	13/16"	1.874"	6.568"	1.00"
12B	75 lb./ft. 12' span	3B38	—	3"	(76mm)	4 ¼"	(108mm)	13/16"	1.148"	2.270"	.60"
		1B48	1B48	4"	(102mm)	5 ¼"	(133mm)	13/16"	1.142"	2.872"	.60"
		3B58	—	5"	(127mm)	6 ¼"	(159mm)	13/16"	1.614"	4.720"	1.00"
		1B68	—	6"	(152mm)	7 ¼"	(184mm)	13/16"	1.874"	6.568"	1.00"
12C	100 lb./ft. 12' span	5B38	—	3"	(76mm)	4 ¼"	(108mm)	13/16"	1.646"	3.350"	1.00"
		3B48	—	4"	(102mm)	5 ¼"	(133mm)	13/16"	1.522"	3.734"	1.00"
		5B58	—	5"	(127mm)	6 ¼"	(159mm)	13/16"	1.944"	5.866"	1.00"
		5B68	—	6"	(152mm)	7 ¼"	(184mm)	13/16"	2.576"	9.032"	1.00"
16A	50 lb./ft. 16' span	5B38	—	3"	(76mm)	4 ¼"	(108mm)	13/16"	1.646"	3.350"	1.00"
		7448	7448	4"	(102mm)	5 ¼"	(133mm)	1 ¼"	2.396"	6.292"	1.50"
		1D58	1D58	5"	(127mm)	6 ¼"	(159mm)	1 ¼"	2.378"	7.202"	1.00"
		5D68	5D68	6"	(152mm)	7 ¼"	(184mm)	1 ¼"	4.874"	17.188"	2.00"
16B	75 lb./ft. 16' span	3D38	3D38	3"	(76mm)	4 ¼"	(108mm)	1 ¼"	2.242"	4.406"	1.50"
		7448	7448	4"	(102mm)	5 ¼"	(133mm)	1 ¼"	2.396"	6.292"	1.50"
		1D58	1D58	5"	(127mm)	6 ¼"	(159mm)	1 ¼"	2.378"	7.202"	1.00"
		5D68	5D68	6"	(152mm)	7 ¼"	(184mm)	1 ¼"	4.874"	17.188"	2.00"
16C	100 lb./ft. 16' span	5D38	5D38	3"	(76mm)	4 ¼"	(108mm)	1 ¼"	2.782"	5.738"	1.50"
		3D48	3D48	4"	(102mm)	5 ¼"	(133mm)	1 ¼"	3.434"	8.746"	2.00"
		5D58	5D58	5"	(127mm)	6 ¼"	(159mm)	1 ¼"	3.542"	10.748"	2.00"
		5D68	5D68	6"	(152mm)	7 ¼"	(184mm)	1 ¼"	4.874"	17.188"	2.00"
20A	50 lb./ft. 20' span	3D38	3D38	3"	(76mm)	4 ¼"	(108mm)	1 ¼"	2.242"	4.406"	1.50"
		7448	7448	4"	(102mm)	5 ¼"	(133mm)	1 ¼"	2.396"	6.292"	1.50"
		1D58	—	5"	(127mm)	6 ¼"	(159mm)	1 ¼"	2.378"	7.202"	1.00"
		5D68	5D68	6"	(152mm)	7 ¼"	(184mm)	1 ¼"	4.874"	17.188"	2.00"
20B	75 lb./ft. 20' span	3D48	—	4"	(102mm)	5 ¼"	(133mm)	1 ¼"	3.434"	8.746"	2.00"
		5D58	5D58	5"	(127mm)	6 ¼"	(159mm)	1 ¼"	3.542"	10.748"	2.00"
		5D68	5D68	6"	(152mm)	7 ¼"	(184mm)	1 ¼"	4.874"	17.188"	2.00"
20C	100 lb./ft. 20' span	7D38	—	3"	(102mm)	4 ¼"	(133mm)	1 ¼"	3.512"	6.956"	2.00"
		5D48	—	4"	(102mm)	5 ¼"	(133mm)	1 ¼"	3.910"	10.020"	2.00"
		7D58	7D58	5"	(127mm)	6 ¼"	(159mm)	1 ¼"	4.186"	12.024"	2.00"
		5D68	5D68	6"	(152mm)	7 ¼"	(184mm)	1 ¼"	4.874"	17.188"	2.00"
EXTRA HEAVY DUTY - VERY LONG SPAN TRAYS- 6, 9 OR 12 RUNG SPACING											
20C+		9D58		5"	(127mm)	6 ¼"	(159mm)	1 ¼"	5.130"	15.700"	2.00"
		7G58		5"	(127mm)	6 ¼"	(159mm)	2"	5.804"	17.456"	2.00"



Ladder Cable Tray System

Aluminum Tray

Load And Deflection Data For Aluminum Ladder Working (Allowable) Load Capacity, Evenly Distributed-Tested per NEMA Standard VE-1, Simple Beam - SAFETY FACTOR 1.5

System Number	6 foot Span			8 foot Span			10 foot Span			12 foot Span			16 foot Span			20 foot Span			24 foot Span			25 foot Span			
	w	d	k	w	d	k	w	d	k	w	d	k	w	d	k	w	d	k	w	d	k	w	d	k	
RT38	222	0.35	0.002	125	0.63	0.005	80	0.99	0.012	55	1.42	0.026													
RT48	324	0.33	0.001	173	0.56	0	117	0.87	0.007	77	1.26	0.016													
RT58	359	0.22	†	191	0.37	0.002	115	0.55	0.005	75	0.74	0.010													
RT68	416	0.18	†	221	0.31	0.001	133	0.46	0.003	87	0.62	0.007													
3B38	354	0.45	0.001	191	0.76	0.004	117	1.14	0.010	78	1.57	0.020													
1B48	324	0.33	0.001	182	0.59	0.003	117	0.87	0.007	77	1.26	0.016													
3B58	359	0.22	†	191	0.37	0.002	115	0.55	0.005	75	0.74	0.010													
1B68	416	0.18	†	221	0.31	0.001	133	0.46	0.003	87	0.62	0.007													
5B38	448	0.39	†	251	0.69	0.003	161	1.08	0.007	112	1.55	0.014													
3B48	394	0.31	†	222	0.55	0.002	142	0.86	0.006	100	1.24	0.012													
5B58	480	0.24	†	257	0.40	0.002	156	0.60	0.004	102	0.81	0.008													
5B68	540	0.17	†	286	0.29	0.001	172	0.43	0.003	111	0.57	0.005													
5B38				251	0.69	0.003	161	1.08	0.007	112	1.55	0.014	51	2.26	0.04	25	2.75	0.11							
7448				349	0.51	0.001	223	0.80	0.004	155	1.15	0.007	79	1.85	0.02	51	2.89	0.06							
1D58				380	0.49	0.001	222	0.69	0.003	154	1.00	0.006	78	1.61	0.02	50	2.51	0.05							
5D68										316	0.86	0.003	161	1.38	0.01	103	2.16	0.02							
3D38				342	0.72	0.002	219	1.12	0.005	152	1.61	0.011	82	2.74	0.03	52	4.27	0.08							
7448				349	0.51	0.001	223	0.80	0.004	155	1.15	0.007	79	1.85	0.02	51	2.89	0.06							
1D58				380	0.49	0.001	222	0.69	0.003	154	1.00	0.006	78	1.61	0.02	50	2.51	0.05							
5D68										316	0.86	0.003	161	1.38	0.01	103	2.16	0.02							
5D38				444	0.71	0.002	284	0.70	0.002	188	1.53	0.008	106	2.73	0.03	65	4.07	0.06							
3D48				525	0.55	0.001	336	0.86	0.003	233	1.24	0.005	119	2.01	0.02	76	3.14	0.04							
5D58										229	1.00	0.004	116	1.60	0.01	75	2.50	0.03							
5D68										316	0.86	0.003	161	1.38	0.01	103	2.16	0.02							
3D38										152	1.61	0.011	82	2.74	0.03	52	4.27	0.08							
7448										155	1.15	0.007	79	1.85	0.02	51	2.89	0.06							
1D58										154	1.00	0.006	78	1.61	0.02	50	2.51	0.05							
5D68										316	0.86	0.003	161	1.38	0.01	103	2.16	0.02							
3D48										233	1.24	0.005	119	2.01	0.02	76	3.14	0.04							
5D58										229	1.00	0.004	116	1.60	0.01	75	2.50	0.03							
5D68										316	0.86	0.003	161	1.38	0.01	103	2.16	0.02							
7D38										277	2.03	0.007	156	3.61	0.02	100	5.64	0.06							
5D48										290	1.35	0.005	156	2.30	0.02	100	3.59	0.04							
7D58							404	0.76	0.002	281	1.09	0.004	158	1.94	0.01	101	3.02	0.03							
5D68										316	0.86	0.003	161	1.38	0.01	103	2.16	0.02							
EXTRA HEAVY DUTY - VERY LONG SPAN TRAYS- 6, 9 OR 12 RUNG SPACING																									
9D58										412	1.22	0.003	214	2.00	0.01	131	3.01	0.02	68	3.23	0.05				
7G58										451	1.20	0.003	253	2.14	0.01	162	3.35	0.02	112	4.79	0.04	104	5.24	0.05	

NOTE: Special Applications Available. Please Contact Factory.
 NOTE: To convert 1.5 safety factor to 2.0 multiply w, d, k by 0.75.
 NOTE: Indicates items included in our Quick Ship Program. Consult factory for lead times on other systems.
 W = Pounds per linear foot
 Metric: for kg/m multiply w by 1.48 d=Deflection (inches)
 k= Deflection (in.) for each pound of load
 †= Denotes k is less than .001 inch

FEATURES
 SWAGE
 I-BEAM
 TROF
 EAGLE BASKET
 CHANNEL
 GLAS
 AICKINSTRUT
 DATA

Steel Tray

NEMA Class, Physical and Structural Properties

NEMA Standard VE-1 Class	NEMA Ld/Span	Mill-Galv. System Number	HDGAF System Number	304 SS System Number	Actual Load Depth		Side Rail Height		Flange Width	1 Sect. Mod. of 2 Rails	Moment of Inertia for 2 Rails I _x	Min X-Sect. Area of 2 Rails per NEC 392.7
8A-12A	75 lb./ft. 12' span	8B36	6237	8B3T	3"	(76mm)	4 ¼"	(108mm)	1 3/16"	0.678 in ³	1.370 in ⁴	0.40 in ²
		8246	6247	824T	4"	(102mm)	5 ¼"	(133mm)	1 3/16"	0.816 in ³	2.142 in ⁴	0.40 in ²
		8256	6257	825T	5"	(127mm)	6 ¼"	(159mm)	1 3/16"	1.072 in ³	3.352 in ⁴	0.70 in ²
		8B66	6B67	8B6T	6"	(152mm)	7 ¼"	(184mm)	1 3/16"	1.574 in ³	5.516 in ⁴	0.70 in ²
12C	100 lb./ft. 12' span	6B36	6B37	6B3T	3"	(76mm)	4 ¼"	(108mm)	1 3/16"	0.834 in ³	1.690 in ⁴	0.70 in ²
		8B46	6B47	8B4T	4"	(102mm)	5 ¼"	(133mm)	1 3/16"	0.924 in ³	2.321 in ⁴	0.40 in ²
		6256	6257	625T	5"	(127mm)	6 ¼"	(159mm)	1 3/16"	1.330 in ³	4.158 in ⁴	0.70 in ²
		8B66	6267	8B6T	6"	(152mm)	7 ¼"	(184mm)	1 3/16"	1.574 in ³	5.516 in ⁴	0.70 in ²
16A	50 lb./ft. 16' span	8D36	6D37	8D3T	3"	(76mm)	4 ¼"	(108mm)	1 3/16"	0.852 in ³	1.736 in ⁴	0.40 in ²
		8D46	6447	8D4T	4"	(102mm)	5 ¼"	(133mm)	1 3/16"	1.146 in ³	2.894 in ⁴	0.70 in ²
		8456	6457	845T	5"	(127mm)	6 ¼"	(159mm)	1 3/16"	1.330 in ³	4.156 in ⁴	0.70 in ²
		6466	6467	646T	6"	(152mm)	7 ¼"	(184mm)	1 3/16"	2.062 in ³	7.478 in ⁴	1.00 in ²
16B	75 lb./ft. 16' span	6D36	6D37	6D3T	3"	(76mm)	4 ¼"	(108mm)	1 3/16"	1.056 in ³	2.152 in ⁴	0.70 in ²
		8D46	6447	8D4T	4"	(102mm)	5 ¼"	(133mm)	1 ¼"	1.146 in ³	2.894 in ⁴	0.70 in ²
		6456	6457	645T	5"	(127mm)	6 ¼"	(159mm)	1 ¼"	1.652 in ³	5.160 in ⁴	1.00 in ²
		6466	6467	646T	6"	(152mm)	7 ¼"	(184mm)	1 ¼"	2.062 in ³	7.478 in ⁴	1.00 in ²
16C	100 lb./ft. 16' span	4D36	4D37	4D3T	3"	(76mm)	4 ¼"	(108mm)	1 ¼"	1.298 in ³	2.652 in ⁴	1.00 in ²
		6446	6447	644T	4"	(102mm)	5 ¼"	(133mm)	1 ¼"	1.280 in ³	3.360 in ⁴	0.70 in ²
		6456	6457	645T	5"	(127mm)	6 ¼"	(159mm)	1 ¼"	1.652 in ³	5.160 in ⁴	1.00 in ²
		8D66	6D67	8D6T	6"	(152mm)	7 ¼"	(184mm)	1 ¼"	1.814 in ³	6.370 in ⁴	0.70 in ²
20A	50 lb./ft. 20' span	6D36	6D37	6D3T	3"	(76mm)	4 ¼"	(108mm)	1 ¼"	1.056 in ³	2.152 in ⁴	0.70 in ²
		6446	6447	644T	4"	(102mm)	5 ¼"	(133mm)	1 ¼"	1.280 in ³	3.360 in ⁴	0.70 in ²
		6456	6457	645T	5"	(127mm)	6 ¼"	(159mm)	1 ¼"	1.652 in ³	5.160 in ⁴	1.00 in ²
		6466	6467	646T	6"	(152mm)	7 ¼"	(184mm)	1 ¼"	2.062 in ³	7.478 in ⁴	1.00 in ²
20B	75 lb./ft. 20' span	2D36	2D37	2D3T	3"	(76mm)	4 ¼"	(108mm)	1 ¼"	1.758 in ³	3.604 in ⁴	1.00 in ²
		4D46	4D47	4D4T	4"	(102mm)	5 ¼"	(133mm)	1 ¼"	1.744 in ³	4.418 in ⁴	1.00 in ²
		6D56	6D57	6D5T	5"	(127mm)	6 ¼"	(159mm)	1 ¼"	1.814 in ³	5.486 in ⁴	1.00 in ²
		6D66	6D67	6D6T	6"	(152mm)	7 ¼"	(184mm)	1 ¼"	2.246 in ³	7.902 in ⁴	1.00 in ²
20C	100 lb./ft. 20' span	2D46	2D47	2D4T	4"	(102mm)	5 ¼"	(133mm)	1 ¼"	2.370 in ³	6.026 in ⁴	1.50 in ²
		4D56	4D57	4D5T	5"	(127mm)	6 ¼"	(159mm)	1 ¼"	2.240 in ³	6.778 in ⁴	1.00 in ²
		4466	4467	446T	6"	(152mm)	7 ¼"	(184mm)	1 ¼"	2.556 in ³	9.264 in ⁴	1.00 in ²
EXTRA HEAVY DUTY - VERY LONG SPAN TRAYS- 6, 9 OR 12 RUNG SPACING												
20C+		2D56	2D57	2D5T	5"	(127mm)	6 ¼"	(159mm)	1 ¼"	3.052 in ³	9.270 in ⁴	1.50 in ²
		11D56	11D57	11D5T	5"	(127mm)	6 ¼"	(159mm)	2"	3.536 in ³	10.630 in ⁴	1.50 in ²

Note: All steel available in 316 upon request.



Ladder Cable Tray System

Steel Tray

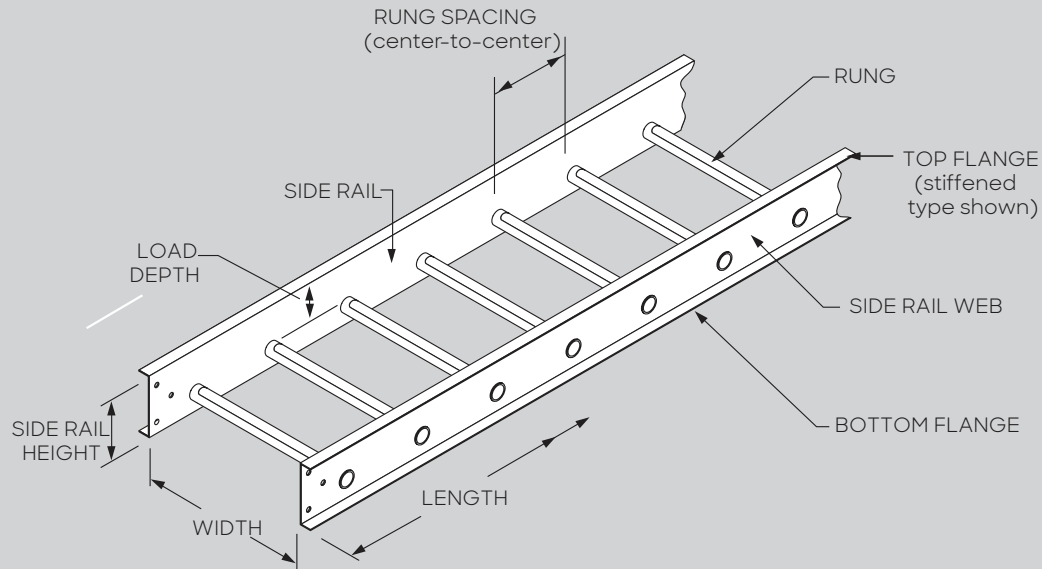
Load and Deflection Data for Steel Ladder Working (Allowable) Load Capacity, Evenly Distributed-Tested per NEMA Standard VE-1, Simple Beam - SAFETY FACTOR 1.5

System Number	6 foot Span			8 foot Span			10 foot Span			12 foot Span			16 foot Span			20 foot Span			24 foot Span			25 foot Span		
	w	d	k	w	d	k	w	d	k	w	d	k	w	d	k	w	d	k	w	d	k	w	d	k
8B36 /6237 /8B3T	360	0.26	†	198	0.46	0.002	124	0.70	0.01	84	1.00	0.01												
8246 /6247 /824T	383	0.18	†	210	0.31	0.001	127	0.46	0.00	83	0.60	0.01												
8256 /6257 /825T	357	0.11	†	194	0.18	†	119	0.28	0.00	79	0.40	0.01												
8B66 /6B67 /8B6T	680	0.12	†	328	0.19	†	182	0.26	0.00	107	0.30	0.00												
6B36 /6B37 /6B3T	453	0.27	†	249	0.47	0.002	156	0.71	0.01	106	1.00	0.01												
8B46 /6B47 /8B4T	456	0.2	†	244	0.33	0.001	152	0.51	0.00	103	0.70	0.01												
6256 /6257 /625T	460	0.11	†	250	0.19		154	0.29	0.00	103	0.40	0.00												
8B66 /6267 /8B6T	680	0.12	†	328	0.19		182	0.26	0.00	107	0.30	0.00												
8D36 /6D37 /8D3T				290	0.53	0.002	182	0.81	0.00	126	1.20	0.01	65	1.9	0.029									
8D46 /6447 /8D4T				382	0.42	0.001	245	0.66	0.00	170	0.90	0.01	86	1.5	0.018									
8456 /6457 /845T				268	0.2	†	166	0.31	0.00	111	0.40	0.00	58	0.7	0.012									
6466 /6467 /646T				372	0.2	†	238	0.24	0.00	178	0.40	0.00	93	0.6	0.007									
6D36 /8D37 /6D3T				381	0.56	0.001	244	0.88	0.00	169	1.30	0.01	88	2.1	0.024									
8D46 /6447 /8D4T				382	0.42	0.001	245	0.66	0.00	170	0.90	0.01	86	1.5	0.018									
6456 /6457 /645T				574	0.35	†	367	0.55	0.00	245	0.80	0.00	123	1.2	0.010									
6466 /6467 /646T				372	0.2	†	238	0.24	0.00	178	0.40	0.00	93	0.6	0.007									
4D36 /4D37 /4D3T				487	0.58	0.001	312	0.91	0.00	216	1.30	0.01	113	2.2	0.019									
6446 /6447 /644T				444	0.42	†	273	0.63	0.00	186	0.90	0.01	100	1.5	0.015									
6456 /6457 /645T				574	0.35	†	367	0.55	0.00	245	0.80	0.00	123	1.2	0.010									
8D66 /6D67 /8D6T				504	0.25	†	306	0.37	0.00	202	0.50	0.00	101	0.8	0.008									
6D36 /6D37 /6D3T										169	1.30	0.01	88	2.1	0.024	52	3	0.057						
6446 /6447 /644T										186	0.90	0.01	100	1.5	0.015	53	1.9	0.037						
6456 /6457 /645T										245	0.80	0.00	123	1.2	0.010	66	1.6	0.024						
6466 /6467 /646T										178	0.40	0.00	93	0.6	0.007	55	0.9	0.017						
2D36 /2D37 /2D3T										304	1.40	0.00	159	2.2	0.014	94	3.2	0.034						
4D46 /4D47 /4D4T										280	1.00	0.00	145	1.7	0.012	85	2.4	0.028						
6D56 /6D57 /6D5T										269	0.80	0.00	139	1.3	0.009	81	1.8	0.022						
6D66 /6D67 /6D6T										291	0.60	0.00	148	1	0.006	85	1.3	0.016						
2D46 /2D47 /2D4T										395	1.10	0.00	206	1.7	0.008	121	2.5	0.021						
4D56 /4D57 /4D5T										296	0.80	0.00	152	1.3	0.008	105	1.9	0.018						
4466 /4467 /446T										379	0.70	0.00	191	1.1	0.005	102	1.4	0.013						
EXTRA HEAVY DUTY - VERY LONG SPAN TRAYS- 6, 9 OR 12 RUNG SPACING																								
2D56 /2D57 /2D5T										490	0.90	0.00	254	1.4	0.006	149	2	0.013	79	1.91	0.024	73	2.38	0.033
11D56 /11D57 /11D5T										434	0.70	†	244	1.2	0.005	156	1.8	0.012	108	2.62	0.024	100	2.85	0.029

Note: To convert 1.5 safety factor to 2.0 multiply w, d, k by 0.75
W=Pounds per linear foot
Metric: for kg/m multiply w by 1.48
d= Deflection (inches)
k= Deflection (in.) for each pound of load
†= Denotes k is less than .001 inch

FEATURES
SWAGE
I-BEAM
TROF
EAGLE BASKET
CHANNEL
GLAS
AICKINSTRUT
DATA

Ladder



Swage Ladder is a structure consisting of two side rails, connected by individual rungs and is manufactured in accordance with NEMA Standard VE-1. Cope rungs are fastened to the side members by an exclusive swaging process. This assembly method ensures a superior mechanical and electrical connection.

Side Members - Cope side members are designed with top and bottom flanges turned outward. This simplifies fastening the cable tray to the supports. Cable tray with outward facing flanges allows complete access within the cable loading area and eliminates the possibility of cable damage from sharp edges within the cable area. The return on the top flange strengthens the side member and allows cable to be smoothly dropped over the side.

Rung - Cope ladder rungs are 1.00" diameter tubing flattened on top to provide a cable bearing surface. This construction allows cable to drop out anywhere without contacting a sharp edge.

Rung Spacing - The interval at which rungs are swaged to the side member is measured from centerline of rung to centerline of rung. Cope manufactures straight lengths with three standard run spacings: 6", 9", and 12". 18" rung spacing is available upon request on widths 24" or smaller. Rung spacing is generally determined by size and type of cable being supported. When in doubt, 9" rung spacing is a typically accepted compromise.

Length - The longitudinal dimensions of standard Cope Cable Ladder are 10', 12', 20', and 24'. Custom lengths may be available upon request.

Ladder Cable Tray System



FEATURES

SWAGE

I-BEAM

TROF

EAGLE BASKET

CHANNEL

GLAS

AICKINSTRUT

DATA

Width – The transverse dimensions of Cope Cable Ladder are measured inside, from side member web to side member web, and are furnished in seven standard widths: 6", 9", 12", 18", 24", 30", and 36". 42" and 48" available upon request.

Overall Width – Overall ladder width is equal to the inside or nominal width plus the width of side member flanges.

Load Depth – Measured from top surface of rung to top of side member, the load depth is not to be confused with overall height. Cope manufactures four loading depths: 3", 4", 5", and 6" in accordance with NEMA Standard VE-1. 2" Nominal load depth is available upon request.

Overall Height – Ladder Tray overall height is equal to the loading depth plus 1 ¼".

Fittings – For changing direction horizontally and vertically, Cope manufactures elbows, tees, and crosses in all widths and loading depths. Fittings are available in three standard radii: 12", 24", and 36". 18" and 48" radii are available upon request. Cope maintains a nominal 9" rung spacing through the centerline of all fittings.

Cope Cable Ladder Features Important Industry - Leading Features:

1. Universal Curvilinear Splice Plate System

The splice plates for rigid connections have a slight curve so they can be used on straight sections or fittings. Tightening of the fastener pulls the plate flush with the side rail. The fasteners are snug and the joint is superior structurally and electrically.

Even when tightened by hand, there is pressure on the fastener to hold it securely.

Note: Heavy Duty, Mid-Span Splice Plates available upon request .

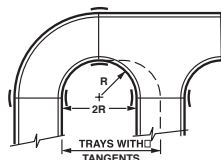
2. Zero Tangent Fittings

Tangent as referred to on cable tray fittings is the straight at the end of the curve to accommodate a flat splice plate. Zero Tangent Fittings facilitate installation when parallel cable trays must be located at minimum distances from each other, such as motor control centers and switch gear centers. Zero tangent fittings can save up to a minimum of 6" per row of tray.

3. Ladder Rung Cable Ladder System Process

The heart of the Cope design is the tubular rung and its connection to the side rail by cold swaging... a process where special machinery compresses and locks the tubular rung material around both the inside and outside of the cable tray side rails. This connection is made without the use of heat, which can potentially disturb the molecular structure of the metal and weaken it.

The tubular rung is flattened during the swaging process to ensure a proper cable bearing surface.



Testing - The superior strength of the swaged ladder tray system has been verified in independent testing conducted by the Pittsburgh Testing Laboratory.

Pullout loads of 2500 lbs were reached. Other tests show the same type rungs, when welded, had a 35% lower pullout load. The

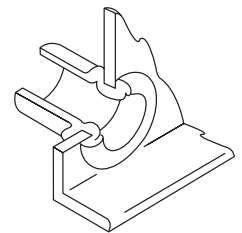
strength of the swage also maintains the 90° relationship of the rungs to the side rail. The tubular rungs, which are very stiff, transmit the cable loads to the side rails resulting in much less deflection than in a similar system with welded rungs.

Ladder Advantages -

Cold swaging allows for the side rails to be turned outward, simplifying cable installation, and provides 100% access to the cables. The cold swaging yields the most rigid tray system in the industry.

The swaged rung connection resists stresses in all directions: up or down, side to side, or in and out. The swaged ladder also resists the camber and warping effects encountered in a typical welded system.

The increased rigidity means that a 24' section of tray can be lifted on one end with little or no twisting or bending of the tray section. This rigid construction makes the trays safer for field personnel to handle and reduces shipping damage.



Electrical Properties - Electrically, the 106 tons of pressure in the swaging process virtually eliminates the interstices and a homogeneous electrical path results.

Resistance of Cope Aluminum Swaged Tray: 31 microhms

Resistance of Cope Steel Swaged Tray: 37.3 microhms

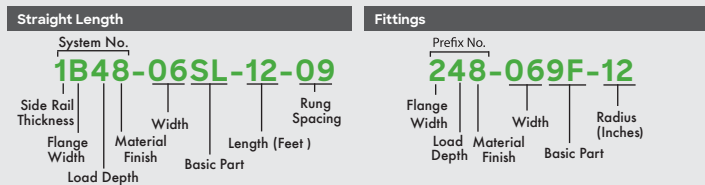
Resistance of Popular Aluminum Welded Tray: 101 microhms

Conclusion - Cold swaging yields a very strong, efficient and aesthetically pleasing system that has stood the test of time and offers installation savings due to its ease of handling.

Ladder Cable Tray System

Part Numbering System

Please pay careful attention to the part numbering structure. Example: Catalog # 1B48-06SL-12-09 is a 4" load depth aluminum ladder with a 13/16" flange, 6" wide, straight length 12' long, rungs on 9" centers. Please make sure to use the system numbers from pages 14 through 17 when ordering.



System Number (Straight Section Only) -

The first four digits make up the system number which identifies the structural, dimensional and material characteristics of the straight length. It is made up of the side rail digits indicating the side rail thickness and flange width, the load depth (inside, in inches), and material finish (aluminum, galvanized, hot dipped, or stainless steel).

Prefix Number (Fittings Only) - Fittings are ordered using the 3-digit prefix number given in the charts on the fitting pages. Fittings do not have stiffened upper flanges.

Width - Identifies the inside width of the tray in inches.

Basic Part Number - Identifies the straight length, fitting, or accessory.

Thickness Aluminum	Thickness Steel	Flange Width	Load Depth	Material Finish
1ga - Thinner	8 - 18ga	2 - 13/16"	3"	6 - Mill-Galv.
3ga	6 - 16ga	B* - 13/16**	4"	7 - HDGAF
5ga**	4 - 14ga	4" - 1 1/4"	5"	8 - Aluminum
7ga	2 - 12ga	D* - 1 1/4"	6"	T - 304SS
9ga - Thicker	11 - 11ga	7 - 2"		
		G* - 2**		

* Note:

*Stiffened upper flange

**Contact factory for 42" and 48" widths (not NEMA Standard)

***18" Rung Spacing only available on widths 24" or less

****Contact factory for 18" and 48" radius (not NEMA Standard)

Secondary Dimension Number - Identifies the length of a straight section in feet, the radius of a fitting in inches, or the second width of a reducer in inches.

Rung Spacing - Identifies the center-to-center distance between rungs on straight length. Nominal 9" (229mm) rung spacing maintained through center line of all fittings.

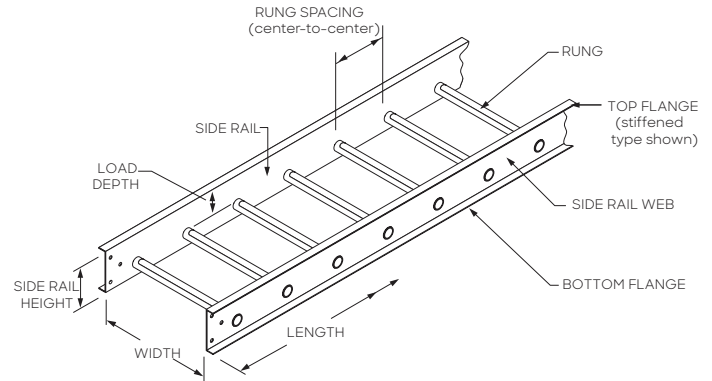
Width**	Part Number	Length	Rung Spacing***
-06=6"	SL (Straight Len.)	10'	-06=6"
-09=9"	9F (90° Horiz. El.)	12'	-09=9"
-12=12"	6F (60° Horiz. El.)	20'	-12=12"
-18=18"	4F (45° Horiz. El.)	24'	-18=18"
-24=24"	3F (30° Horiz. El.)		
-30=30"	90 (90° Out. Vert.El.)		
-36=36"	60 (60° Out. Vert. El.)		
-42=42"	40 (45° Out. Vert. El.)		Radius****
-48=48"	30 (30° Out. Vert. El.)		-12=12"
	9I (90° In. Vert. El.)		-18=18"
	6I (60° In. Vert. El.)		-24=24"
	4I (45° In. Vert. El.)		-36=36"
	3I (30° In. Vert. El.)		-48=48"
	FT (Horiz. Tee)		
	FC (Horiz. Cross)		
	TT (Horiz. Tapped Tee)		
	TC (Horiz. Tapped Cross)		
	VT (Vert. Tee)		
	SR (Vert. Cable Support Elbow)		
	ST (Straight Reducer)		
	RH (Right Hand Reducer)		
	LH (Left Hand Reducer)		
	AF (Adjustable Elbow)		
	LY (45° Left Y Branch)		
	RY (45° Right Y Branch)		

Straight Length [SL]

Straight length ladder is manufactured in 10' (CSA), 12', 20' (CSA), and 24' lengths; 6", 9", 12", 18", 24", 30", and 36" widths; and 3", 4", 5", and 6" load depths. Rungs are 1" diameter tubes with a $\frac{7}{8}$ " flattened cable support surface. 6", 9", 12", and 18" rung spacings are available. Fittings have nominal 9" rung spacing through center line. Dimensions given are inside. For overall widths add two flange widths of the system selected (see Selection Charts). Some systems have stiffened upper (top) flanges to obtain rigidity required (see Selection Charts).

Rungs are assembled to side rails by Cope's exclusive cold swaging process. Outward facing flanges allow full unobstructed access to contents of tray in width and depth.

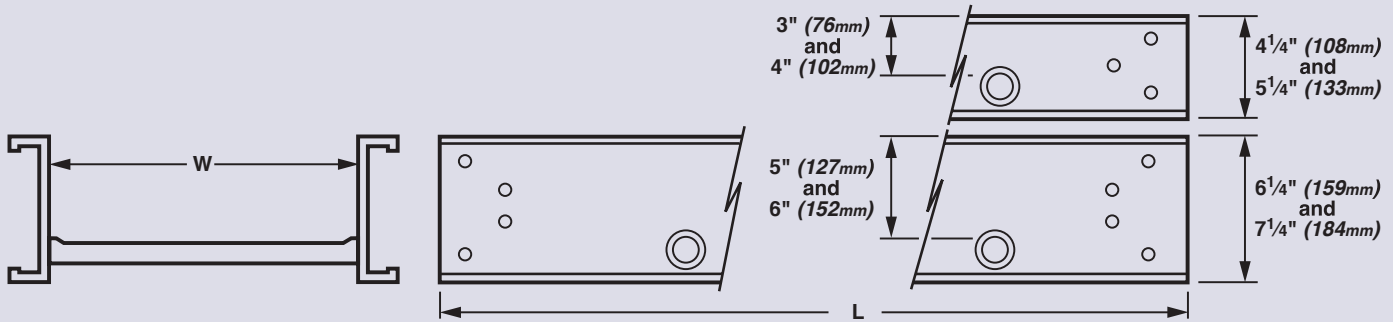
Materials: Aluminum Hot Dip Mill-Galvanized (pre-galvanized) to ASTM A-653, Hot Dip Galvanized After Fabrication (HDGAF) to ASTM A-123, Stainless Steel (Type 304 and 316).



Sufficient connectors are supplied to assemble straight sections and fittings for each order. Connectors for field cuts are to be ordered separately (see Connectors).



Ladder Cable Tray System



Catalog

System	Width	Basic No.	Length NEMA	Rung Spacing
	-06=6"	SL	12'	-06=6"
	-09=9"		24'	-09=9"
See	-12=12"		10'	-12=12"
Pages	-18=18"		20'	-18=18"
14 - 17	-24=24"		CSA	
	-30=30"		-10	
	-36=36"		-20	
	-42=42***			
	-48=48***			

* 10' & 12' all NEMA Classes, 20' & 24' NEMA Classes 16A, 16B, 16C, 20A, 20B, 20C.

** not NEMA standard width

Example: Catalog # 6247-06SL-12-09 is a 4" load depth hot dipped ladder with a 13/16 flange, 6 inches wide, straight length 12 feet long, rungs on 9 centers.

Conversion Table

English	6"	9"	12"	18"	24"	30"	36"
Metric	152mm	229mm	305mm	457mm	610mm	762mm	914mm
English	12'	24'	10'	20'			
Metric	3.7m	7.3m	3m	6m			

Material & Finish Specifications (Ladder Cable Tray)

System	Pre-Galvanized Steel	Hot-Dip Galvanized after fabrication ASTM A-123	Aluminum	Type 304 Stainless Steel
Siderails	ASTM A-653-G90 CS (18 & 16 Gage) ASTM A-653-G90 CS (14 & 12 Gage)	ASTM A-1008 (18 & 16 Gage) ASTM A-1011 (14 & 12 Gage)	AA-6063-T6 Extruded	ASTM A-240; Type 304
Rungs	ASTM A-653-G90 CS	ASTM A-1008	AA-6063-T6 Extruded* AA-6063-T832 Extruded* AA-6063-T52 Extruded*	ASTM A-269; Type 304
Splice Plate Finish	ASTM A-1011 ASTM A-591 Class C	ASTM A-1011 ASTM A-123 Grade 65	AA-5052-H34	ASTM A-240; Type 304, 2B Finish (Typical)
Connector Bolts	SAE J429 Grade 1 (ASTM A-307 Grade A)	SAE J429 Grade 1 (ASTM A-307 Grade A)	SAE J429 Grade 1 (ASTM A-307 Grade A)	AISI Type 304 Stainless Steel
Bolt Plating	ASTM B-633.0002 Zinc	ASTM B-633.0002 Zinc	ASTM B-633.0002 Zinc	AISI Type 304 Stainless Steel
Covers	ASTM A-653-G90 CQ	ASTM A-653-G90 CQ	AA-3003 H14 or 3150 H14	ASTM A-240; Type 304

Electrical Grounding Chart

Table 1 below provides the Minimum Cross Sectional area for two side rails. Using the Fitting Prefix Number (ex: 247), the proper value is determined by the Flange Width (1st column), Load Depth (2nd column), and Material (3rd column). Locate the line containing the Flange Width (column 1) and follow it to the right to the appropriate Load Depth and Material.

Find that value in Table 2, follow it to the right to the Material column to determine the Maximum Ground Fault Amperage.

Table 1

Fitting Prefix Number			Min. X-Sect for 2 Rails (NEC® Table 392.7B)			
			Aluminum		Steel	
Flange	Load Depth	Material	^{13/16} Flange	¹ / ₄ Flange	^{13/16} Flange	¹ / ₄ Flange
			X-Sect Area	X-Sect Area	X-Sect Area	X-Sect Area
2" - ^{13/16} "	3"	6 - Mill Gal	0.60	0.60	0.40	0.70
4" - ¹ / ₄ "	4"	7 - HDGAF	0.60	0.60	0.40	0.70
	5"	8 - Alum.	0.60	1.00	0.70	0.70
	6"		0.60	1.00	0.70	1.00

Table 2

Maximum Ground Fault Amperage (in Amps)		
X-Sect Area	Material	
	Aluminum	Steel
.40 sq ²	-	100
.60 sq ²	1000	-
.70 sq ²	-	200
1.00 sq ²	1200	400

For Example: If the fitting prefix is 248, the Flange is ¹³/₁₆, the Load Depth is 4, and the Material is Aluminum. The Minimum Cross Sectional Area (X-Sect Area) is 0.60 sq. in. The Amperage is 1000.



Ladder Cable Tray System

Typical Specifications

By specifying the NEMA class designation, you will use the simplest, clearest, and most complete method of specification available and automatically incorporate support span in feet, working (allowable) load in pounds per linear foot, a safety factor of 1.5, a concentrated load, if present; and, all other design, manufacturing, and test standards including electrical continuity.

All you need to do is add the desired load depth, rung spacing, radius of fittings, metal, and finish. You may add accessory information pursuant to your project. Here is a typical specification for an outdoor tray system where the working (allowable) load has been determined to be approximately 75 pounds per foot on support spans of 12'-0".

Specification Aluminum Cope Ladder System

Ladder Cable Tray shall be manufactured by a company regularly engaged in the manufacture of metal cable trays and shall be a member of NEMA. Trays shall conform to NEMA Metal Cable Tray Standard Publication VE-1 (latest issue).

1. Ladder Cable Tray shall be NEMA Classification 12B of the widths indicated.
2. Material shall be aluminum alloy with side rails and rungs of 6063.
3. Finish shall be natural.
4. Inside load depth to be NEMA Standard 3.
5. Fittings shall be 12 radius for control cables and 24 radius for power cables. (This must be coensurate with the cable manufacturer's recommended minimum bending radius.)
6. All top level trays in stacks and single runs to have raised, peaked aluminum ventilated covers with heavy duty hold down clamps every 3'-0.
7. Install expansion connectors, expansion guides, and hold down clamps per NEMA Standard VE-1.
8. Where slopes or horizontal bends of trays are not at the Standard NEMA angles, use adjustable connectors. If the angle is too great for cable bending radius, use combinations of fitting and adjustable connectors.
9. Separate all cables of different voltages in the same tray using the manufacturer's standard barriers and barrier hold down system.
10. The Ladder Cable Tray system will be used as an equipment grounding conductor.
11. To save space fittings shall have no tangents. To facilitate field installation, use one pair of universal type connector plates for rigid joints.
12. Ladder Cable Tray shall have outward facing side rails with tubular rungs assembled into side rails by cold swaging. Cable support surface on top of rungs to be flattened. Inside of tray shall not have flanges or other projections. Full access to the contents of the Ladder Cable Tray shall be available.
13. Trays shall be Cope Ladder Cable Tray System Number 3B38 as manufactured by Cope Cable Tray®.

CSA System Selection Chart

Certified CSA Load Class	Cope System	Load Depth		Side Rail		Flange Width	Max. Load (lb/ft)	Maximum Support Span	Deflection at Max Support Span	Meets CSA Elec. Tests
ALUMINUM LADDER TRAY - Safety Factor: 1.5										
C	1B38	3"	(76mm)	4 ¼"	(108mm)	1 ⅜"	65	3m	25.1	Yes
D	3D38	3"	(76mm)	4 ¼"	(108mm)	1 ¼"	45	6m (1)	108.5	Yes
16C	5D38	3"	(76mm)	4 ¼"	(108mm)	1 ¼"	100	4.9m	69.3	Yes
C	1B48	4"	(102mm)	5 ¼"	(133mm)	1 ⅜"	65	3m	22.1	Yes
20A	7448	4"	(102mm)	5 ¼"	(133mm)	1 ¼"	50	6m (1)	73.4	Yes
20B	3D48	4"	(102mm)	5 ¼"	(133mm)	1 ¼"	75	6m (1)	79.8	Yes
20A	1D58	5"	(127mm)	6 ¼"	(159mm)	1 ¼"	50	6m (1)	63.8	Yes
20B	5D58	5"	(127mm)	6 ¼"	(159mm)	1 ¼"	75	6m (1)	54.9	Yes
E	3658	5"	(127mm)	6 ¼"	(159mm)	1 ¾"	75	6m (1)	64.8	Yes
20C	7D58	5"	(127mm)	6 ¼"	(159mm)	1 ¼"	100	6m (1)	76.7	Yes
20C	5D68	6"	(152mm)	7 ¼"	(184mm)	1 ¼"	100	6m (1)	54.9	Yes
Mil Gal STEEL LADDER TRAY Safety Factor: 1.5										
C	8B36	3"	(76mm)	4 ¼"	(108mm)	1 ⅜"	65	3m	17.8	Yes
20A	6456	5"	(127mm)	6 ¼"	(159mm)	1 ¼"	50	6m (1)	40.4	Yes
E	6D56	5"	(127mm)	6 ¼"	(159mm)	1 ¼"	75	6m (1)	46.2	Yes
20C	4D56	5"	(127mm)	7 ¼"	(184mm)	1 ¼"	100	6m (1)	48.5	Yes
12B	8B66	6"	(152mm)	7 ¼"	(184mm)	1 ⅜"	75	3.7m	24.9	Yes
20A	6466	6"	(152mm)	7 ¼"	(184mm)	1 ¼"	50	6m (1)	23.1	Yes
20B	6D66	6"	(152mm)	7 ¼"	(184mm)	1 ¼"	75	6m (1)	33.8	Yes
HDGAF STEEL LADDER TRAY Safety Factor: 1.5										
C	8B37	3"	(76mm)	4 ¼"	(108mm)	1 ⅜"	65	3m	17.8	Yes
20A	6457	5"	(127mm)	6 ¼"	(159mm)	1 ¼"	50	6m (1)	40.4	Yes
E	6D57	5"	(127mm)	6 ¼"	(159mm)	1 ¼"	75	6m (1)	46.2	Yes
12B	8B67	6"	(152mm)	7 ¼"	(184mm)	1 ⅜"	75	3.7m	24.9	Yes
20A	6467	6"	(152mm)	7 ¼"	(184mm)	1 ¼"	50	6m (1)	23.1	Yes
20B	6D67	6"	(152mm)	7 ¼"	(184mm)	1 ¼"	75	6m (1)	33.8	Yes



Certified Ladder Cable Tray Systems That Meet Performance Class CSA Std.C22.2

CSA Loads

Identify the desired load designation needed for your project from the chart below. Both CSA Class and NEMA designations are listed by load capability and span. Then select the CSA Certified Cope System from the table above. Where CSA C22.2 is not mandatory, you may want to consider other Cope systems offered on the selection charts (page 44 - 45).

Load, kg/m (lb/ft)	Span, m (ft)				
	2.4 (8)	3.0 (10)	3.7 (12)	4.9 (16)	6.0 (20)
37 (25)	-	A	-	-	-
67 (45)	-	-	-	-	D
74 (50)	8A	-	12A	16A	20A
97 (65)	-	C	-	-	-
112 (75)	8B	-	12B	16B	E or 20B
149 (100)	8C	-	12C	16C	20C
179 (120)	-	D	-	-	-
299 (200)	-	E	-	-	-

Note: 8A/B/C, 12A/B/C, 16A/B/C, and 20A/B/C have been NEMA designations. A, B, C, D and E are CSA designations.



Ladder Cable Tray System

CSA System Selection Chart

Receiving, Installing, and Maintenance

The proper care and handling of cable trays by the receiver and installers is very important to ensure a safe installation that will meet the intended service life. Cope has an installation guide available to assist the installers and those who will maintain the installed system.

Dimensions and Structural Properties: Cope CSA Systems

The performance of the Cope cable tray systems certified by CSA is given above. Structural properties of straight sections,

though not required to be listed, are given in the Cope NEMA selection charts, in English units. Dimensions of straight sections and certified fittings are furnished in English and metric units for use in layout and/or entry into computerized systems.

Note: For other CSA approved systems please contact the factory at atkore.com/cope

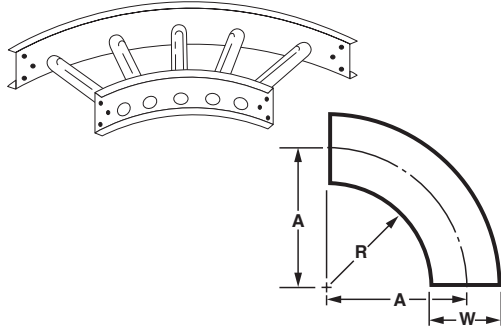
Fittings

Aluminum	
System Fitting	Number Prefix
1B38	238
1B48	248
3B58	258
1B68	268
3B38	238
5B38	238
3B48	248
5B58	258
5B68	268
7448	448
1D58	458
5D68	468
3D38	438
5D38	438
3D48	448
5D58	458
7D38	438
5D48	448
7D58	458
9D58	458
7G58	758
5D68	468

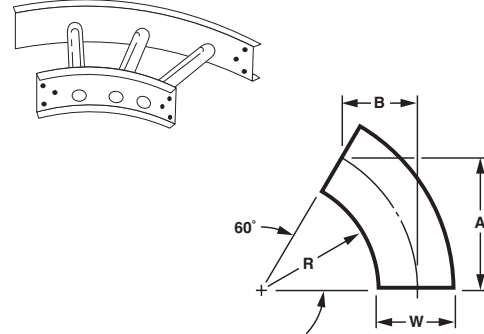
Mill-Galv	
System Fitting	Number Prefix
6B36	236
8246	246
8256	256
8B36	236
8B46	246
8B66	266
6256	256
8D36	436
8D46	446
8456	456
6D36	436
4D36	436
6446	446
6456	456
8D66	466
6466	466
4D46	446
6D56	456
6D66	466
4D56	456
4466	466
2D36	436
2D46	446
2D56	456
11D56	456

HDGAF	
System Fitting	Number Prefix
6237	237
6247	247
6257	257
6B67	267
6B37	237
6B47	247
6267	267
6D37	437
6447	447
6457	457
6467	467
6D37	437
4D37	437
6D67	467
2D37	437
4D37	464
6D57	457
2D47	447
4D57	457
4467	467
2D57	457
11D57	457

90° Horizontal Elbow [9F]



60° Horizontal Elbow [6F]



Radius - R	Width - W	A Dimension	
12" (305mm)	6" (152mm)	15"	(381mm)
	9" (229mm)	16 1/2"	(419mm)
	12" (305mm)	18"	(457mm)
	18" (457mm)	21"	(533mm)
	24" (610mm)	24"	(610mm)
	30" (762mm)	27"	(686mm)
	36" (914mm)	30"	(762mm)
	42" (1067mm)	33"	(838mm)
48" (1219mm)	36"	(914mm)	
24" (610mm)	6" (152mm)	27"	(686mm)
	9" (229mm)	28 1/2"	(724mm)
	12" (305mm)	30"	(762mm)
	18" (457mm)	33"	(838mm)
	24" (610mm)	36"	(914mm)
	30" (762mm)	39"	(991mm)
	36" (914mm)	42"	(1067mm)
	42" (1067mm)	45"	(1143mm)
48" (1219mm)	48"	(1219mm)	
36" (914mm)	6" (152mm)	39"	(991mm)
	9" (229mm)	40 1/2"	(1029mm)
	12" (305mm)	42"	(1067mm)
	18" (457mm)	45"	(1143mm)
	24" (610mm)	48"	(1219mm)
	30" (762mm)	51"	(1295mm)
	36" (914mm)	54"	(1372mm)
	42" (1067mm)	57"	(1448mm)
48" (1219mm)	60"	(1524mm)	

Radius - R	Width - W	A Dimension	B Dimension
12" (305mm)	6" (152mm)	13" (330mm)	7 1/2" (191mm)
	9" (229mm)	14 1/4" (362mm)	8 1/4" (210mm)
	12" (305mm)	15 5/8" (397mm)	9" (229mm)
	18" (457mm)	18 1/4" (464mm)	10 1/2" (267mm)
	24" (610mm)	20 3/4" (527mm)	12" (305mm)
	30" (762mm)	23 3/8" (594mm)	13 1/2" (343mm)
	36" (914mm)	26" (660mm)	15" (381mm)
	42" (1067mm)	28 5/16" (725mm)	16 1/2" (419mm)
48" (1219mm)	31 1/8" (791mm)	18" (457mm)	
24" (610mm)	6" (152mm)	23 3/8" (594mm)	13 1/2" (343mm)
	9" (229mm)	24 3/4" (629mm)	14 1/4" (362mm)
	12" (305mm)	26" (660mm)	15" (381mm)
	18" (457mm)	28 5/8" (727mm)	16 1/2" (416mm)
	24" (610mm)	31 1/4" (794mm)	18" (457mm)
	30" (762mm)	33 3/4" (857mm)	19 1/2" (495mm)
	36" (914mm)	36 3/8" (924mm)	21" (533mm)
	42" (1067mm)	38 15/16" (989mm)	22 1/2" (572mm)
48" (1219mm)	41 9/16" (1056mm)	24" (610mm)	
36" (914mm)	6" (152mm)	33 3/4" (857mm)	19 1/2" (495mm)
	9" (229mm)	35 1/8" (892mm)	20 1/4" (514mm)
	12" (305mm)	36 3/8" (924mm)	21" (533mm)
	18" (457mm)	39" (991mm)	22 1/2" (572mm)
	24" (610mm)	41 5/8" (1057mm)	24" (610mm)
	30" (762mm)	44 1/8" (1121mm)	25 1/2" (648mm)
	36" (914mm)	46 3/4" (1187mm)	27" (686mm)
	42" (1067mm)	49 5/16" (1253mm)	28 1/2" (724mm)
48" (1219mm)	51 15/16" (1319mm)	30" (762mm)	

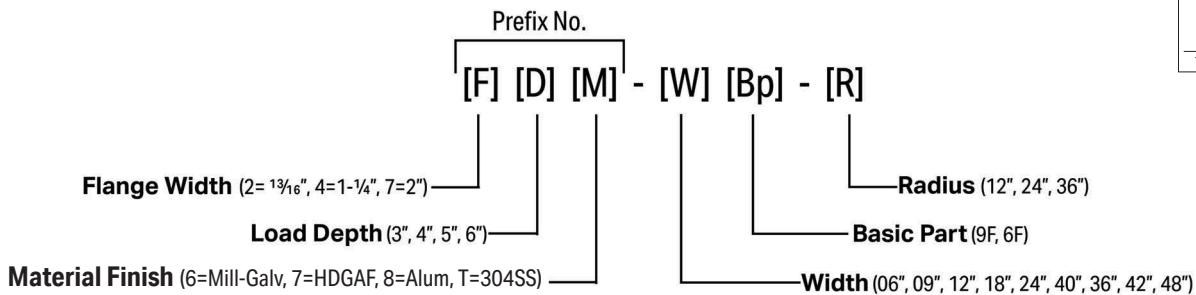
Example: 238-129F-12

Note: Use Adjustable Connectors for odd angles. Nominal 9" rung spacing maintained through centerline of all fittings.

Example: 238-124F-12

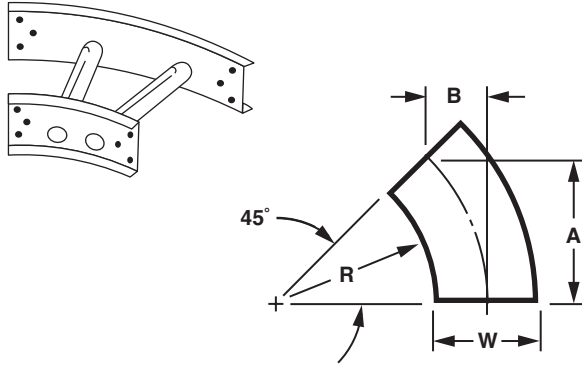
Note: Use Adjustable Connectors for odd angles. Nominal 9" rung spacing maintained through centerline of all fittings.

See Page 24
for Electrical
Grounding Chart

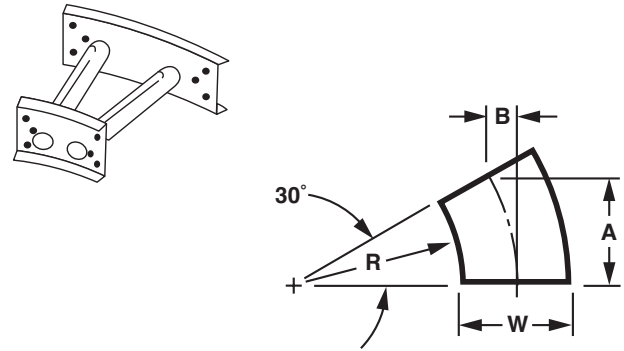


Ladder Cable Tray System

45° Horizontal Elbow [4F]



30° Horizontal Elbow [3F]



Radius - R	Width - W	A Dimension	B Dimension
12" (305mm)	6" (152mm)	10 5/8" (270mm)	4 3/8" (111mm)
	9" (229mm)	11 5/8" (295mm)	4 7/8" (124mm)
	12" (305mm)	12 3/4" (324mm)	5 1/4" (133mm)
	18" (457mm)	14 7/8" (378mm)	6 1/8" (156mm)
	24" (610mm)	17" (432mm)	7" (178mm)
	30" (762mm)	19 7/8" (486mm)	7 7/8" (200mm)
	36" (914mm)	21 1/4" (540mm)	8 3/4" (222mm)
	42" (1067mm)	23 3/16" (592mm)	9 5/8" (244mm)
	48" (1219mm)	25 7/16" (646mm)	10 1/2" (267mm)
24" (610mm)	6" (152mm)	19 1/8" (486mm)	7 7/8" (200mm)
	9" (229mm)	20 1/8" (511mm)	8 3/8" (213mm)
	12" (305mm)	21 1/4" (540mm)	8 3/4" (222mm)
	18" (457mm)	23 3/8" (594mm)	9 5/8" (244mm)
	24" (610mm)	25 1/2" (648mm)	10 1/2" (267mm)
	30" (762mm)	27 5/8" (702mm)	11 1/2" (292mm)
	36" (914mm)	29 3/4" (756mm)	12 3/8" (314mm)
	42" (1067mm)	31 13/16" (808mm)	13 1/8" (333mm)
	48" (1219mm)	33 15/16" (862mm)	14" (356mm)
36" (914mm)	6" (152mm)	27 5/8" (702mm)	11 1/2" (292mm)
	9" (229mm)	28 5/8" (727mm)	11 7/8" (302mm)
	12" (305mm)	29 3/4" (756mm)	12 3/8" (314mm)
	18" (457mm)	31 7/8" (810mm)	13 1/4" (337mm)
	24" (610mm)	34" (864mm)	14 1/8" (359mm)
	30" (762mm)	36 1/8" (918mm)	15" (381mm)
	36" (914mm)	38 1/4" (972mm)	15 7/8" (403mm)
	42" (1067mm)	40 1/4" (1022mm)	16 11/16" (424mm)
	48" (1219mm)	42 3/8" (1076mm)	17 9/16" (446mm)

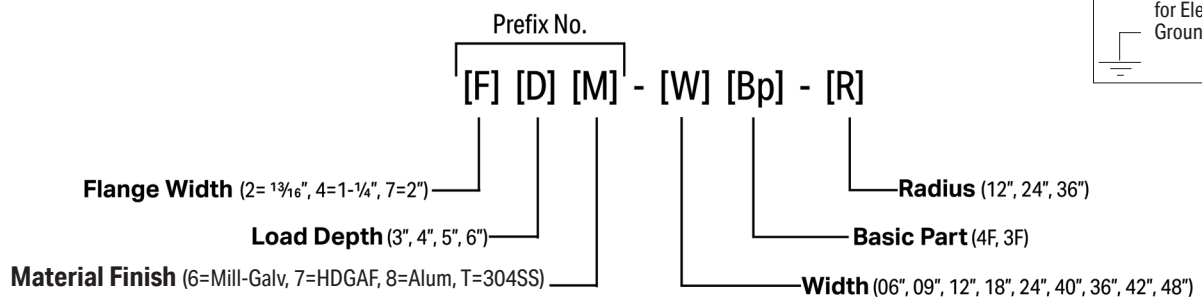
Example: 238-124F-12

Note: Use Adjustable Connectors for odd angles. Nominal 9" rung spacing maintained through centerline of all fittings.

Radius - R	Width - W	A Dimension	B Dimension
12" (305mm)	6" (152mm)	7 1/2" (191mm)	2" (51mm)
	9" (229mm)	8 1/4" (210mm)	2 1/4" (57mm)
	12" (305mm)	9" (229mm)	2 3/8" (60mm)
	18" (457mm)	10 1/2" (267mm)	2 7/8" (73mm)
	24" (610mm)	12" (305mm)	3 1/4" (83mm)
	30" (762mm)	13 1/2" (343mm)	3 5/8" (92mm)
	36" (914mm)	15" (381mm)	4" (102mm)
	42" (1067mm)	16 1/2" (419mm)	4 3/8" (111mm)
	48" (1219mm)	18" (457mm)	4 13/16" (122mm)
24" (610mm)	6" (152mm)	13 1/2" (343mm)	3 5/8" (92mm)
	9" (229mm)	14 1/4" (362mm)	3 7/8" (98mm)
	12" (305mm)	15" (381mm)	4" (102mm)
	18" (457mm)	16 1/2" (419mm)	4 3/8" (111mm)
	24" (610mm)	18" (457mm)	4 7/8" (124mm)
	30" (762mm)	19 1/2" (495mm)	5 1/4" (133mm)
	36" (914mm)	21" (533mm)	5 5/8" (143mm)
	42" (1067mm)	22 1/2" (572mm)	6" (152mm)
	48" (1219mm)	24" (610mm)	6 3/8" (162mm)
36" (914mm)	6" (152mm)	19 1/2" (495mm)	5 1/4" (133mm)
	9" (229mm)	20 1/4" (514mm)	5 1/2" (140mm)
	12" (305mm)	21" (533mm)	5 5/8" (143mm)
	18" (457mm)	22 1/2" (572mm)	6" (152mm)
	24" (610mm)	24" (610mm)	6 1/2" (165mm)
	30" (762mm)	25 1/2" (648mm)	6 7/8" (175mm)
	36" (914mm)	27" (686mm)	7 1/4" (184mm)
	42" (1067mm)	28 1/2" (724mm)	7 5/8" (194mm)
	48" (1219mm)	30" (762mm)	8" (203mm)

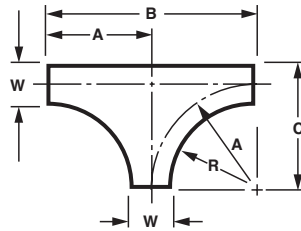
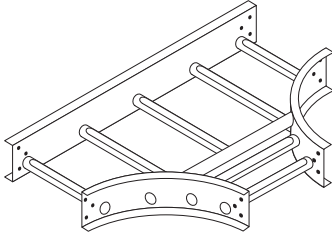
Example: 238-123F-12

Note: Use Adjustable Connectors for odd angles. Nominal 9" rung spacing maintained through centerline of all fittings.



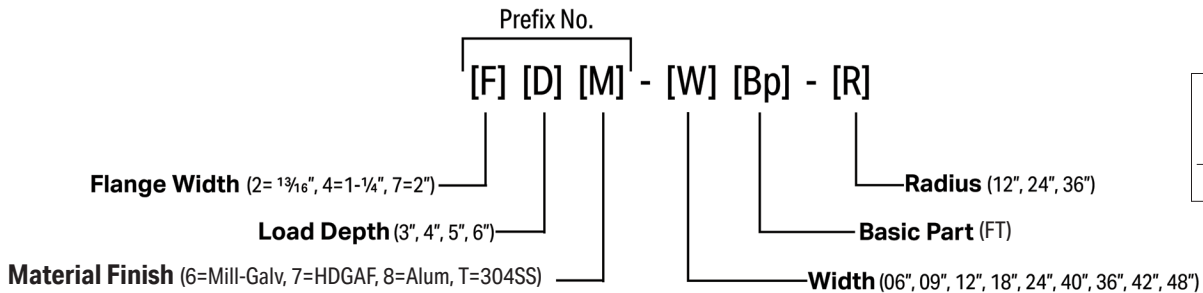
See Page 24
for Electrical
Grounding Chart

Horizontal Tee [FT]



Radius - R	Width - W	A Dimension	B Dimension	C Dimension
12" (305mm)	6" (152mm)	15" (381mm)	30" (762mm)	18" (457mm)
	9" (229mm)	16½" (419mm)	33" (838mm)	21" (533mm)
	12" (305mm)	18" (457mm)	36" (914mm)	24" (610mm)
	18" (457mm)	21" (533mm)	42" (1067mm)	30" (762mm)
	24" (610mm)	24" (610mm)	48" (1219mm)	36" (914mm)
	30" (762mm)	27" (686mm)	54" (1372mm)	42" (1067mm)
	36" (914mm)	30" (762mm)	60" (1524mm)	48" (1219mm)
	42" (1067mm)	33" (838mm)	66" (1676mm)	54" (1372mm)
24" (610mm)	48" (1219mm)	36" (914mm)	72" (1829mm)	60" (1524mm)
	6" (152mm)	27" (686mm)	54" (1372mm)	30" (762mm)
	9" (229mm)	28½" (724mm)	57" (1448mm)	33" (838mm)
	12" (305mm)	30" (762mm)	60" (1524mm)	36" (914mm)
	18" (457mm)	33" (838mm)	66" (1676mm)	42" (1067mm)
	24" (610mm)	36" (914mm)	72" (1829mm)	48" (1219mm)
	30" (762mm)	39" (991mm)	78" (1981mm)	54" (1372mm)
	36" (914mm)	42" (1067mm)	84" (2134mm)	60" (1524mm)
36" (914mm)	42" (1067mm)	45" (1143mm)	90" (2286mm)	66" (1676mm)
	48" (1219mm)	48" (1219mm)	96" (2438mm)	72" (1829mm)
	6" (152mm)	39" (991mm)	78" (1981mm)	42" (1067mm)
	9" (229mm)	40½" (1029mm)	81" (2057mm)	45" (1143mm)
	12" (305mm)	42" (1067mm)	84" (2134mm)	48" (1219mm)
	18" (457mm)	45" (1143mm)	90" (2286mm)	54" (1372mm)
	24" (610mm)	48" (1219mm)	96" (2438mm)	60" (1524mm)
	30" (762mm)	51" (1295mm)	102" (2591mm)	66" (1676mm)
36" (914mm)	54" (1372mm)	108" (2743mm)	72" (1829mm)	
42" (1067mm)	57" (1448mm)	114" (2896mm)	78" (1981mm)	
48" (1219mm)	60" (1524mm)	120" (3048mm)	84" (2134mm)	

Example: 238-12FT-12
Nominal 9" rung spacing maintained through centerline of all fittings.

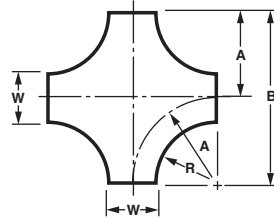
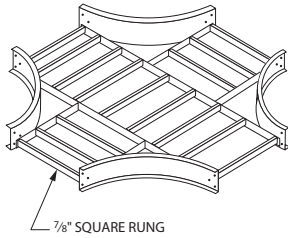


See Page24
for Electrical
Grounding Chart



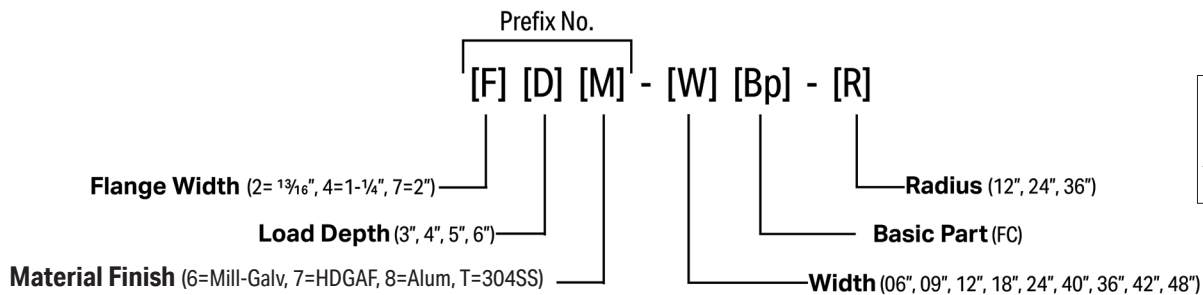
Ladder Cable Tray System

Horizontal Cross [FC]

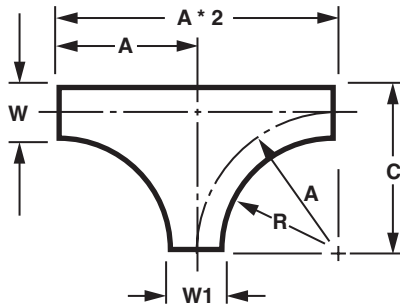
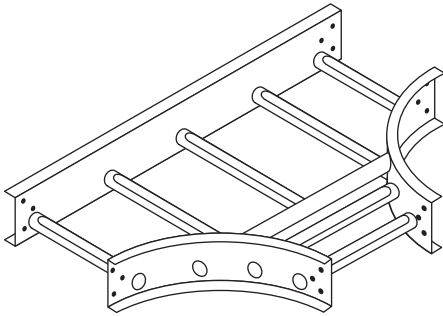


Radius - R	Width - W	A Dimension	B Dimension
12" (305mm)	6" (152mm)	15" (381mm)	30" (762mm)
	9" (229mm)	16 1/2" (419mm)	33" (838mm)
	12" (305mm)	18" (457mm)	36" (914mm)
	18" (457mm)	21" (533mm)	42" (1067mm)
	24" (610mm)	24" (610mm)	48" (1219mm)
	30" (762mm)	27" (686mm)	54" (1372mm)
	36" (914mm)	30" (762mm)	60" (1524mm)
	42" (1067mm)	33" (838mm)	66" (1676mm)
24" (610mm)	48" (1219mm)	36" (914mm)	72" (1829mm)
	6" (152mm)	27" (686mm)	54" (1372mm)
	9" (229mm)	28 1/2" (724mm)	57" (1448mm)
	12" (305mm)	30" (762mm)	60" (1524mm)
	18" (457mm)	33" (838mm)	66" (1676mm)
	24" (610mm)	36" (914mm)	72" (1829mm)
	30" (762mm)	39" (991mm)	78" (1981mm)
	36" (914mm)	42" (1067mm)	84" (2134mm)
36" (914mm)	42" (1067mm)	45" (1143mm)	90" (2286mm)
	48" (1219mm)	48" (1219mm)	96" (2438mm)
	6" (152mm)	39" (991mm)	78" (1981mm)
	9" (229mm)	40 1/2" (1029mm)	81" (2057mm)
	12" (305mm)	42" (1067mm)	84" (2134mm)
	18" (457mm)	45" (1143mm)	90" (2286mm)
	24" (610mm)	48" (1219mm)	96" (2438mm)
	30" (762mm)	51" (1295mm)	102" (2591mm)
36" (914mm)	54" (1372mm)	108" (2743mm)	
42" (1067mm)	57" (1448mm)	114" (2896mm)	
48" (1219mm)	60" (1524mm)	120" (3048mm)	

Example: 238-12FT-12
Nominal 9" rung spacing maintained through centerline of all fittings.



Horizontal Tapped Tee [TT]



Example: 238-12TT-09-12
 Note: Nominal 9" rung spacing maintained through centerline of all fittings.
 Expanding taps available upon request.

See Page 24
 for Electrical
 Grounding Chart

Horizontal Tapped Tee [TT]

Radius - R	Width - W	Width - W1	A Dimension	C Dimension			
12" (305mm)	48" (1219mm)	42" (1067mm)	33" (838mm)	60" (1524mm)			
		36" (914mm)	30" (762mm)				
		30" (762mm)	27" (686mm)				
		24" (610mm)	24" (610mm)				
		18" (457mm)	21" (533mm)				
		12" (305mm)	18" (457mm)				
		9" (229mm)	16 1/2" (419mm)				
12" (305mm)	42" (1067mm)	36" (914mm)	30" (762mm)	54" (1372mm)			
		30" (762mm)	27" (686mm)				
		24" (610mm)	24" (610mm)				
		18" (457mm)	21" (533mm)				
		12" (305mm)	18" (457mm)				
		9" (229mm)	16 1/2" (419mm)				
		6" (152mm)	15" (381mm)				
12" (305mm)	36" (914mm)	30" (762mm)	27" (686mm)	48" (1219mm)			
		24" (610mm)	24" (610mm)				
		18" (457mm)	21" (533mm)				
		12" (305mm)	18" (457mm)				
		9" (229mm)	16 1/2" (419mm)				
		6" (152mm)	15" (381mm)				
		12" (305mm)	30" (762mm)		24" (610mm)	24" (610mm)	42" (1067mm)
18" (457mm)	21" (533mm)						
12" (305mm)	18" (457mm)						
9" (229mm)	16 1/2" (419mm)						
6" (152mm)	15" (381mm)						
12" (305mm)	24" (610mm)			18" (457mm)	21" (533mm)	36" (914mm)	
				12" (305mm)	18" (457mm)		
		9" (229mm)	16 1/2" (419mm)				
		6" (152mm)	15" (381mm)				
		12" (305mm)	18" (457mm)	12" (305mm)	18" (457mm)		30" 7 (762mm)
				9" (229mm)	16 1/2" (419mm)		
				6" (152mm)	15" (381mm)		
12" (305mm)	12" (305mm)	9" (229mm)	16 1/2" (419mm)	24" (610mm)			
		6" (152mm)	15" (381mm)				
9" (229mm)	6" (152mm)	15" (381mm)	21" (533mm)				

Prefix No.
 [F] [D] [M] - [W] [Bp] - [R]

Flange Width (2=1 3/16", 4=1-1/4", 7=2")

Load Depth (3", 4", 5", 6")

Material Finish (6=Mill-Galv, 7=HDGAF, 8=Alum, T=304SS)

Radius (12", 24", 36")

Basic Part (TT)

Width (06", 09", 12", 18", 24", 40", 36", 42", 48")



Ladder Cable Tray System

Horizontal Tapped Tee [TT]					Horizontal Tapped Tee [TT]				
Radius - R	Width - W	Width - W1	A Dimension	C Dimension	Radius - R	Width - W	Width - W1	A Dimension	C Dimension
24" (610mm)	48" (1219mm)	42" (1067mm)	45" (1143mm)	72" (1829mm)	36" (914mm)	48" (1219mm)	42" (1067mm)	57" (1448mm)	84" (2134mm)
		36" (914mm)	42" (1067mm)				36" (914mm)	54" (1372mm)	
		30" (762mm)	39" (991mm)				30" (762mm)	51" (1295mm)	
		24" (610mm)	36" (914mm)				24" (610mm)	48" (1219mm)	
		18" (457mm)	33" (838mm)				18" (457mm)	45" (1143mm)	
		12" (305mm)	30" (762mm)				12" (305mm)	42" (1067mm)	
		9" (229mm)	28 ½" (724mm)				9" (229mm)	40½" (1029mm)	
	6" (152mm)	27" (686mm)	6" (152mm)	39" (991mm)					
	42" (1067mm)	36" (914mm)	42" (1067mm)	66" (1676mm)		42" (1067mm)	36" (914mm)	54" (1372mm)	78" (191mm)
		30" (762mm)	39" (991mm)				30" (762mm)	51" (1295mm)	
24" (610mm)		36" (914mm)	24" (610mm)		48" (1219mm)				
18" (457mm)		33" (838mm)	18" (457mm)		45" (1143mm)				
12" (305mm)		30" (762mm)	12" (305mm)		42" (1067mm)				
9" (229mm)		28 ½" (724mm)	9" (229mm)		40½" (1029mm)				
6" (152mm)		27" (686mm)	6" (152mm)		39" (991mm)				
30" (762mm)	24" (610mm)	36" (914mm)	54" (1372mm)	30" (762mm)	24" (610mm)	48" (1219mm)	66" (1676mm)		
	18" (457mm)	33" (838mm)			18" (457mm)	45" (1143mm)			
	12" (305mm)	30" (762mm)			12" (305mm)	42" (1067mm)			
	9" (229mm)	28 ½" (724mm)			9" (229mm)	40½" (1029mm)			
	6" (152mm)	27" (686mm)			6" (152mm)	39" (991mm)			
24" (610mm)	18" (457mm)	33" (838mm)	48" (1219mm)	24" (610mm)	18" (457mm)	45" (1143mm)	60" (1524mm)		
	12" (305mm)	30" (762mm)			12" (305mm)	42" (1067mm)			
	9" (229mm)	28 ½" (724mm)			9" (229mm)	40½" (1029mm)			
	6" (152mm)	27" (686mm)			6" (152mm)	39" (991mm)			
18" (457mm)	12" (305mm)	30" (762mm)	42" (1067mm)	18" (457mm)	12" (305mm)	42" (1067mm)	54" (1372mm)		
	9" (229mm)	28 ½" (724mm)			9" (229mm)	40½" (1029mm)			
	6" (152mm)	27" (686mm)			6" (152mm)	39" (991mm)			
12" (305mm)	9" (229mm)	28 ½" (724mm)	36" (914mm)	12" (305mm)	9" (229mm)	40½" (1029mm)	48" (1219mm)		
	6" (152mm)	27" (686mm)			6" (152mm)	39" (991mm)			
9" (229mm)	6" (152mm)	27" (686mm)	33" (838mm)	9" (229mm)	6" (152mm)	39" (991mm)	45" (1143mm)		

FEATURES

SWAGE

I-BEAM

TROF

EAGLE BASKET

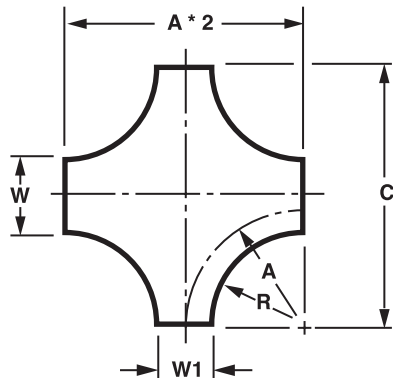
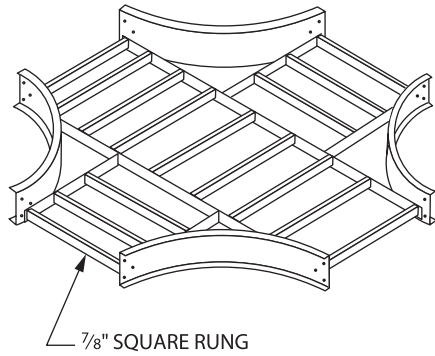
CHANNEL

GLAS

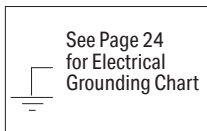
AICKINSTRUT

DATA

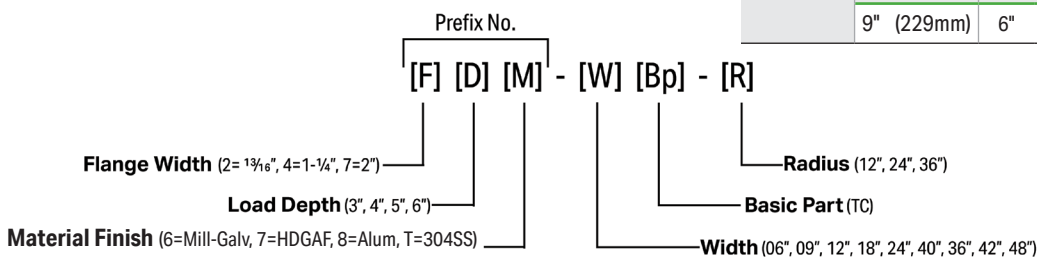
Horizontal Tapped Cross [TC]



Example: 238-36TC-18-12
 Note: Nominal 9" rung spacing maintained through centerline of all fittings.
 Expanding taps available upon request.



Horizontal Tapped Cross [TC]					
Radius - R	Width - W	Width - W1	A Dimension	C Dimension	
12" (305mm)	48" (1219mm)	42" (1067mm)	33" (838mm)	72" (1829mm)	
		36" (914mm)	30" (762mm)		
		30" (762mm)	27" (686mm)		
		24" (610mm)	24" (610mm)		
		18" (457mm)	21" (533mm)		
		12" (305mm)	18" (457mm)		
	42" (1067mm)	36" (914mm)	30" (762mm)	66" (1676mm)	
		30" (762mm)	27" (686mm)		
		24" (610mm)	24" (610mm)		
		18" (457mm)	21" (533mm)		
		12" (305mm)	18" (457mm)		
		9" (229mm)	16 1/2" (419mm)		
36" (914mm)	30" (762mm)	27" (686mm)	60" (1524mm)		
	24" (610mm)	24" (610mm)			
	18" (457mm)	21" (533mm)			
	12" (305mm)	18" (457mm)			
	9" (229mm)	16 1/2" (419mm)			
	6" (152mm)	15" (381mm)			
30" (762mm)	24" (610mm)	24" (610mm)	54" (1372mm)		
	18" (457mm)	21" (533mm)			
	12" (305mm)	18" (457mm)			
	9" (229mm)	16 1/2" (419mm)			
	6" (152mm)	15" (381mm)			
	24" (610mm)	18" (457mm)		21" (533mm)	48" (1219mm)
12" (305mm)		18" (457mm)			
9" (229mm)		16 1/2" (419mm)			
6" (152mm)		15" (381mm)			
18" (457mm)		12" (305mm)	18" (457mm)	42" (1067mm)	
		9" (229mm)	16 1/2" (419mm)		
	6" (152mm)	15" (381mm)			
12" (305mm)	9" (229mm)	16 1/2" (419mm)	36" (914mm)		
	6" (152mm)	15" (381mm)			
9" (229mm)	6" (152mm)	15" (381mm)	33" (838mm)		



Ladder Cable Tray System

Horizontal Tapped Cross [TC]				
Radius - R	Width - W	Width - W1	A Dimension	C Dimension
24" (610mm)	48" (1219mm)	42" (1067mm)	45" (1143mm)	9" (2438mm)
		36" (914mm)	42" (1067mm)	
		30" (762mm)	39" (991mm)	
		24" (610mm)	36" (914mm)	
		18" (457mm)	33" (838mm)	
		12" (305mm)	30" (762mm)	
		9" (229mm)	28 ½" (724mm)	
	6" (152mm)	27" (686mm)		
	42" (1067mm)	36" (914mm)	42" (1067mm)	90" (2286mm)
		30" (762mm)	39" (991mm)	
		24" (610mm)	36" (914mm)	
		18" (457mm)	33" (838mm)	
		12" (305mm)	30" (762mm)	
		9" (229mm)	28 ½" (724mm)	
		6" (152mm)	27" (686mm)	
	36" (914mm)	30" (762mm)	39" (991mm)	84" (2134mm)
		24" (610mm)	36" (914mm)	
		18" (457mm)	33" (838mm)	
		12" (305mm)	30" (762mm)	
		6" (152mm)	27" (686mm)	
	30" (762mm)	24" (610mm)	36" (914mm)	78" (1981mm)
		18" (457mm)	33" (838mm)	
		12" (305mm)	30" (762mm)	
		6" (152mm)	27" (686mm)	
	24" (610mm)	18" (457mm)	33" (838mm)	72" (1829mm)
		12" (305mm)	30" (762mm)	
		6" (152mm)	27" (686mm)	
	18" (457mm)	12" (305mm)	30" (762mm)	66" (1676mm)
9" (229mm)		28 ½" (724mm)		
6" (152mm)		27" (686mm)		
12" (305mm)	9" (229mm)	28 ½" (724mm)	60" (1524mm)	
	6" (152mm)	27" (686mm)		
9" (229mm)	6" (152mm)	27" (686mm)	57" (1448mm)	

Horizontal Tapped Cross [TC]				
Radius - R	Width - W	Width - W1	A Dimension	C Dimension
36" (914mm)	48" (1219mm)	42" (1067mm)	57" (1448mm)	120" (3048mm)
		36" (914mm)	54" (1372mm)	
		30" (762mm)	51" (1295mm)	
		24" (610mm)	48" (1219mm)	
		18" (457mm)	45" (1143mm)	
		12" (305mm)	42" (1067mm)	
		9" (229mm)	40 ½" (1029mm)	
	6" (152mm)	39" (991mm)		
	42" (1067mm)	36" (914mm)	54" (1372mm)	114" (2896mm)
		30" (762mm)	51" (1295mm)	
		24" (610mm)	48" (1219mm)	
		18" (457mm)	45" (1143mm)	
		12" (305mm)	42" (1067mm)	
		9" (229mm)	40 ½" (1029mm)	
		6" (152mm)	39" (991mm)	
	36" (914mm)	30" (762mm)	51" (1295mm)	108" (2743mm)
		24" (610mm)	48" (1219mm)	
		18" (457mm)	45" (1143mm)	
		12" (305mm)	42" (1067mm)	
		6" (152mm)	39" (991mm)	
	30" (762mm)	24" (610mm)	48" (1219mm)	102" (2591mm)
		18" (457mm)	45" (1143mm)	
		12" (305mm)	42" (1067mm)	
		6" (152mm)	39" (991mm)	
	24" (610mm)	18" (457mm)	45" (1143mm)	96" (2438mm)
		12" (305mm)	42" (1067mm)	
		6" (152mm)	39" (991mm)	
	18" (457mm)	12" (305mm)	42" (1067mm)	90" (2286mm)
9" (229mm)		40 ½" (1029mm)		
6" (152mm)		39" (991mm)		
12" (305mm)	9" (229mm)	40 ½" (1029mm)	84" (2134mm)	
	6" (152mm)	39" (991mm)		
9" (229mm)	6" (152mm)	39" (991mm)	81" (2057mm)	

FEATURES

SWAGE

I-BEAM

TROF

EAGLE BASKET

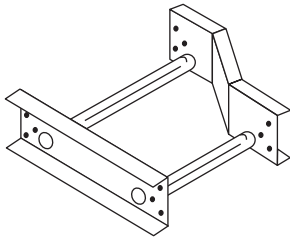
CHANNEL

GLAS

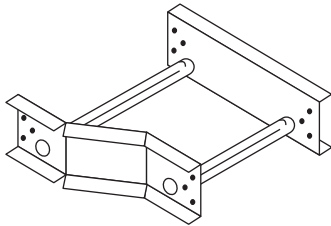
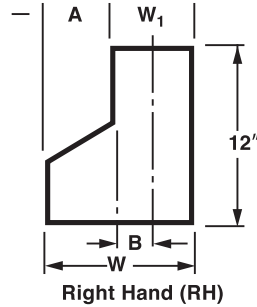
AICKINSTRUT

DATA

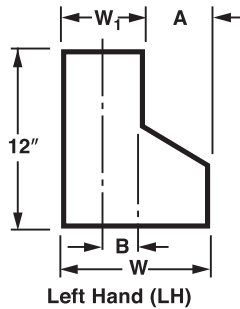
Right Hand [RH] Reducer
Left Hand [LH] Reducer



RIGHT HAND (RH)

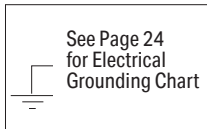


LEFT HAND (LH)



Example: 238-12LH-06

Note: Nominal 9" rung spacing maintained through centerline of all fittings.
Expanding taps available upon request.



Left Hand [LH] & Right Hand [RH] Reducer

Width - W	Width - W1	A Dimension		B Dimension	
48" (1219mm)	42" (1067mm)	6" (152mm)	21" (533mm)	6" (152mm)	21" (533mm)
	36" (914mm)	12" (305mm)	18" (457mm)	6" (152mm)	18" (457mm)
	30" (762mm)	18" (457mm)	15" (381mm)	6" (152mm)	15" (381mm)
	24" (610mm)	24" (610mm)	12" (305mm)	6" (152mm)	12" (305mm)
	18" (457mm)	30" (762mm)	9" (229mm)	6" (152mm)	9" (229mm)
	12" (305mm)	36" (914mm)	6" (152mm)	6" (152mm)	6" (152mm)
	9" (229mm)	39" (991mm)	4 1/2" (114mm)	3" (76mm)	3" (76mm)
	6" (152mm)	42" (1067mm)	3" (76mm)	3" (76mm)	3" (76mm)
42" (1067mm)	36" (914mm)	6" (152mm)	18" (457mm)	6" (152mm)	18" (457mm)
	30" (762mm)	12" (305mm)	15" (381mm)	6" (152mm)	15" (381mm)
	24" (610mm)	18" (457mm)	12" (305mm)	6" (152mm)	12" (305mm)
	18" (457mm)	24" (610mm)	9" (229mm)	6" (152mm)	9" (229mm)
	12" (305mm)	30" (762mm)	6" (152mm)	6" (152mm)	6" (152mm)
	9" (229mm)	33" (838mm)	4 1/2" (114mm)	3" (76mm)	3" (76mm)
36" (914mm)	30" (762mm)	6" (152mm)	15" (381mm)	6" (152mm)	15" (381mm)
	24" (610mm)	12" (305mm)	12" (305mm)	6" (152mm)	12" (305mm)
	18" (457mm)	18" (457mm)	9" (229mm)	6" (152mm)	9" (229mm)
	12" (305mm)	24" (610mm)	6" (152mm)	6" (152mm)	6" (152mm)
	9" (229mm)	27" (686mm)	4 1/2" (114mm)	3" (76mm)	3" (76mm)
	6" (152mm)	30" (762mm)	3" (76mm)	3" (76mm)	3" (76mm)
30" (762mm)	24" (610mm)	6" (152mm)	12" (305mm)	6" (152mm)	12" (305mm)
	18" (457mm)	12" (305mm)	9" (229mm)	6" (152mm)	9" (229mm)
	12" (305mm)	18" (457mm)	6" (152mm)	6" (152mm)	6" (152mm)
	9" (229mm)	21" (533mm)	4 1/2" (114mm)	3" (76mm)	3" (76mm)
24" (610mm)	18" (457mm)	6" (152mm)	9" (229mm)	6" (152mm)	9" (229mm)
	12" (305mm)	12" (305mm)	6" (152mm)	6" (152mm)	6" (152mm)
	9" (229mm)	15" (381mm)	4 1/2" (114mm)	3" (76mm)	3" (76mm)
	6" (152mm)	18" (457mm)	3" (76mm)	3" (76mm)	3" (76mm)
18" (457mm)	12" (305mm)	6" (152mm)	6" (152mm)	6" (152mm)	6" (152mm)
	9" (229mm)	9" (229mm)	4 1/2" (114mm)	3" (76mm)	3" (76mm)
	6" (152mm)	12" (305mm)	3" (76mm)	3" (76mm)	3" (76mm)
12" (305mm)	9" (229mm)	3" (76mm)	4 1/2" (114mm)	3" (76mm)	3" (76mm)
	6" (152mm)	6" (152mm)	3" (76mm)	3" (76mm)	3" (76mm)
9" (229mm)	6" (152mm)	3" (76mm)	3" (76mm)	3" (76mm)	3" (76mm)

Prefix No.
[F] [D] [M] - [W] [Bp] - [R]

Flange Width (2= 1 3/8", 4= 1-1/4", 7= 2")

Load Depth (3", 4", 5", 6")

Material Finish (6=Mill-Galv, 7=HDGAF, 8=Alum, T=304SS)

Radius (12", 24", 36")

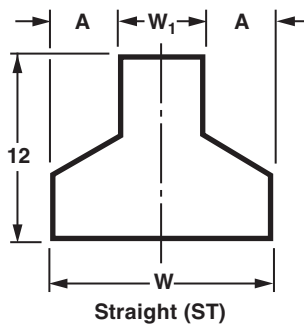
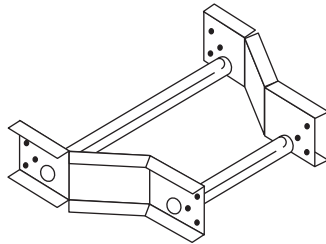
Basic Part (LH, RH)

Width (06", 09", 12", 18", 24", 40", 36", 42", 48")



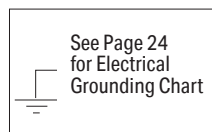
Ladder Cable Tray System

Straight Reducer [ST]



Example: 238-12ST-06

Note: Nominal 9" rung spacing maintained through centerline of all fittings.



Straight Reducer [ST]			
Width - W	Width - W1		A Dimension
48" (1219mm)	42"	(1067mm)	3" (76mm)
	36"	(914mm)	6" (152mm)
	30"	(762mm)	9" (229mm)
	24"	(610mm)	12" (305mm)
	18"	(457mm)	15" (381mm)
	12"	(305mm)	18" (457mm)
	9"	(229mm)	19 1/2" (495mm)
42" (1067mm)	6"	(152mm)	21" (533mm)
	36"	(914mm)	3" (76mm)
	30"	(762mm)	6" (152mm)
	24"	(610mm)	9" (229mm)
	18"	(457mm)	12" (305mm)
	12"	(305mm)	15" (381mm)
	9"	(229mm)	16 1/2" (419mm)
36" (914mm)	6"	(152mm)	18" (457mm)
	30"	(762mm)	3" (76mm)
	24"	(610mm)	6" (152mm)
	18"	(457mm)	9" (229mm)
	12"	(305mm)	12" (305mm)
30" (762mm)	9"	(229mm)	13 1/2" (343mm)
	6"	(152mm)	15" (381mm)
	24"	(610mm)	3" (76mm)
	18"	(457mm)	6" (152mm)
24" (610mm)	12"	(305mm)	9" (229mm)
	9"	(229mm)	10 1/2" (267mm)
	6"	(152mm)	12" (304mm)
18" (457mm)	18"	(457mm)	3" (76mm)
	12"	(305mm)	6" (152mm)
	9"	(229mm)	7 1/2" (191mm)
12" (305mm)	6"	(152mm)	9" (229mm)
	12"	(305mm)	3" (76mm)
	9"	(229mm)	4 1/2" (114mm)
9" (229mm)	6"	(152mm)	6" (152mm)
	6"	(152mm)	1 1/2" (38mm)

Prefix No.
[F] [D] [M] - [W] [Bp] - [R]

Flange Width (2=1 3/8", 4=1-1/4", 7=2")

Load Depth (3", 4", 5", 6")

Material Finish (6=Mill-Galv, 7=HDGAF, 8=Alum, T=304SS)

Radius (12", 24", 36")

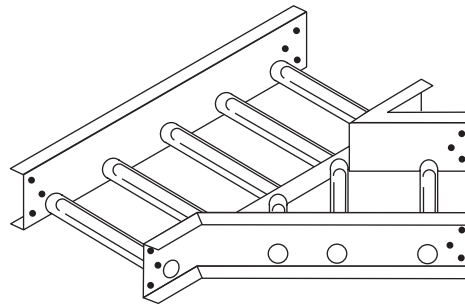
Basic Part (ST)

Width (06", 09", 12", 18", 24", 40", 36", 42", 48")



45° Y Branch Left Hand [LY] & Right Hand [RY]

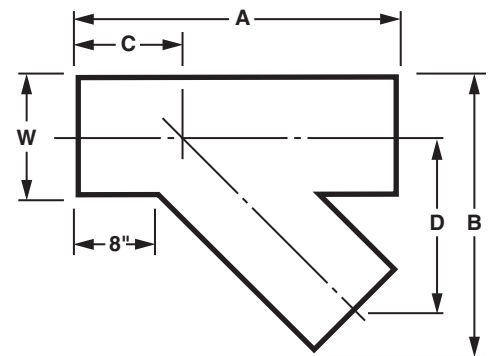
Right Hand (RY) Shown



See Page 24
for Electrical
Grounding Chart

Width - W	A Dim.	B Dim.	C Dim.	D Dim.
6" (152mm)	22½" (571mm)	16¼" (413mm)	9¼" (235mm)	11⅞" (283mm)
9" (229mm)	26¾" (679mm)	21⅜" (543mm)	9⅞" (249mm)	13¾" (349mm)
12" (305mm)	31" (787mm)	26½" (673mm)	10½" (267mm)	16¼" (412mm)
18" (457mm)	39½" (1003mm)	36¾" (933mm)	11¾" (298mm)	21⅞" (543mm)
24" (610mm)	48" (1219mm)	47" (1193mm)	13" (330mm)	26½" (673mm)
30" (762mm)	56⅞" (1432mm)	57¼" (1454mm)	14⅞" (359mm)	31⅞" (803mm)
36" (914mm)	65" (1651mm)	67½" (1714mm)	15½" (394mm)	36¾" (933mm)
42" (1067mm)	73⅞" (1864mm)	77⅞" (1972mm)	16¾" (425mm)	41¾" (1060mm)
48" (1219mm)	81⅞" (2080mm)	87⅞" (2232mm)	18" (457mm)	46⅞" (1191mm)

Example: 238-12LY

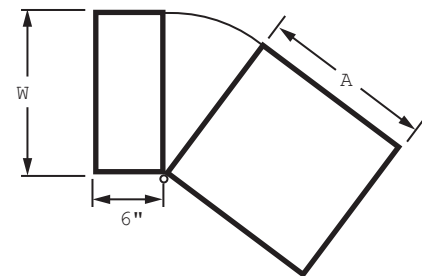
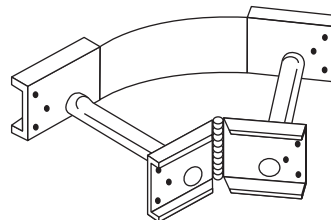


Adjustable Elbow [AF]

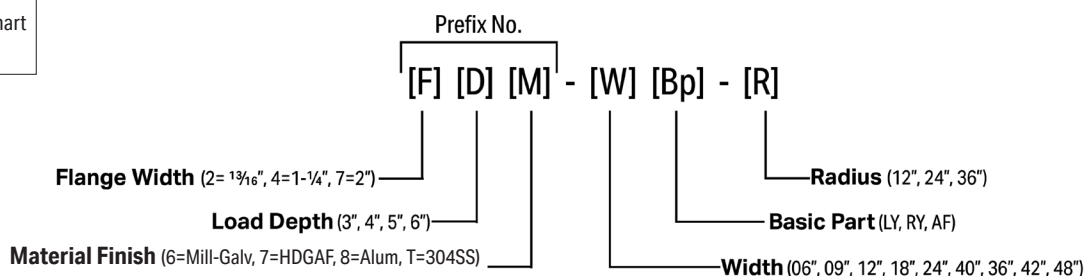
Width - W	A Dimension
6" (152mm)	8" (203mm)
9" (229mm)	11" (279mm)
12" (305mm)	14" (356mm)
18" (457mm)	20" (508mm)
24" (610mm)	26" (660mm)
30" (762mm)	32" (813mm)
36" (914mm)	38" (965mm)
42" (1067mm)	44" (1118mm)
48" (1219mm)	50" (1270mm)

Example: 237-12AF

Note: Nominal 9" rung spacing maintained through centerline of all fittings.

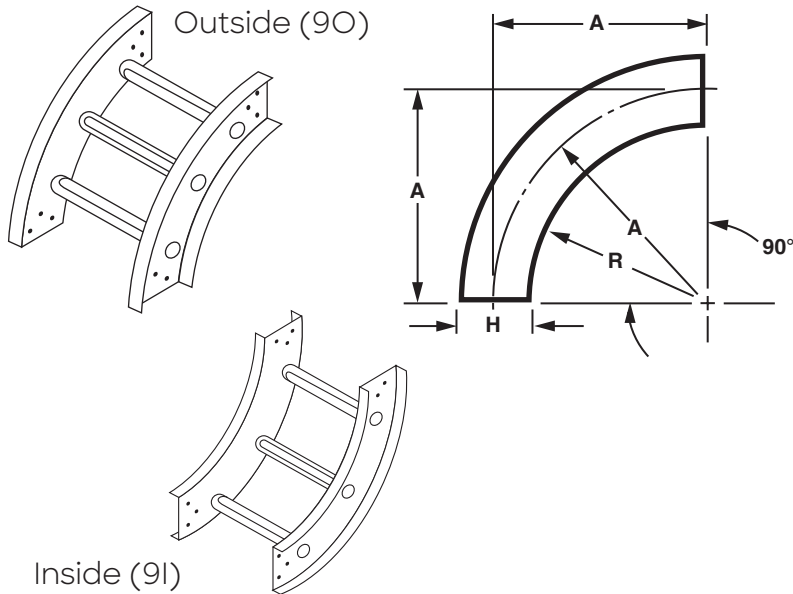


See Page 24
for Electrical
Grounding Chart



Ladder Cable Tray System

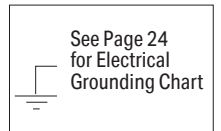
90° Vertical Elbow Outside [90] & Inside [91]



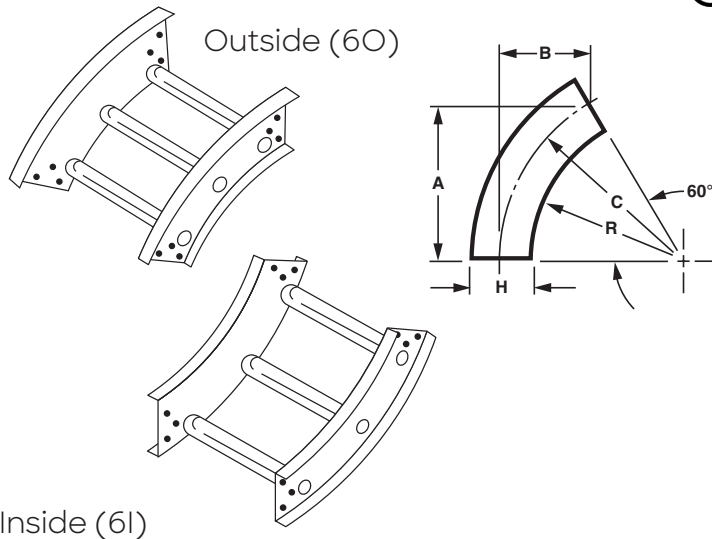
Radius - R	H Dim.	A Dim.
12" (305mm)	4 1/4" (108mm)	14 1/8" (359mm)
	5 1/4" (133mm)	14 5/8" (372mm)
	6 1/4" (159mm)	15 1/8" (384mm)
	7 1/4" (184mm)	15 5/8" (397mm)
24" (610mm)	4 1/4" (108mm)	26 1/8" (664mm)
	5 1/4" (133mm)	26 5/8" (676mm)
	6 1/4" (159mm)	27 1/8" (689mm)
36" (914mm)	4 1/4" (108mm)	38 1/8" (969mm)
	5 1/4" (133mm)	38 5/8" (981mm)
	6 1/4" (159mm)	39 1/8" (994mm)
	7 1/4" (184mm)	39 5/8" (1007mm)

Example: 238-1290-12

Note: Use Adjustable Connectors for odd angles. Nominal 9" rung spacing maintained through centerline of all fittings.



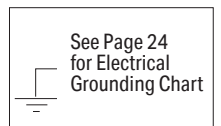
60° Vertical Elbow Outside [60] & Inside [61]



Radius - R	H Dim.	A Dim.	B Dim.	C Dim.
12" (305mm)	4 1/4" (108mm)	12 1/4" (311mm)	7 1/8" (181mm)	14 1/8" (359mm)
	5 1/4" (133mm)	12 5/8" (321mm)	7 3/8" (187mm)	14 5/8" (372mm)
	6 1/4" (159mm)	13 1/8" (334mm)	7 5/8" (194mm)	15 1/8" (384mm)
	7 1/4" (184mm)	13 1/2" (343mm)	7 7/8" (200mm)	15 5/8" (397mm)
24" (610mm)	4 1/4" (108mm)	22 5/8" (575mm)	13 3/8" (334mm)	26 1/8" (664mm)
	5 1/4" (133mm)	23 1/8" (588mm)	13 3/8" (340mm)	26 5/8" (676mm)
	6 1/4" (159mm)	23 1/2" (597mm)	13" (330mm)	27 1/8" (689mm)
36" (914mm)	4 1/4" (108mm)	33" (838mm)	19 1/8" (486mm)	38 1/8" (969mm)
	5 1/4" (133mm)	33 1/2" (851mm)	19 3/8" (492mm)	38 5/8" (981mm)
	6 1/4" (159mm)	33 7/8" (861mm)	19 5/8" (499mm)	39 1/8" (994mm)
	7 1/4" (184mm)	34 3/8" (873mm)	19 7/8" (505mm)	39 5/8" (1007mm)

Example: 238-1260-12

Note: Use Adjustable Connectors for odd angles. Nominal 9" rung spacing maintained through centerline of all fittings.



Prefix No.

[F] [D] [M] - [W] [Bp] - [R]

Flange Width (2= 1 3/16", 4=1-1/4", 7=2")

Load Depth (3", 4", 5", 6")

Material Finish (6=Mill-Galv, 7=HDGAF, 8=Alum, T=304SS)

Radius (12", 24", 36")

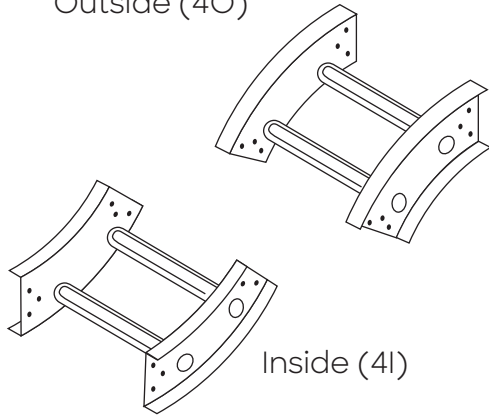
Basic Part (90, 91, 60, 61)

Width (06", 09", 12", 18", 24", 40", 36", 42", 48")

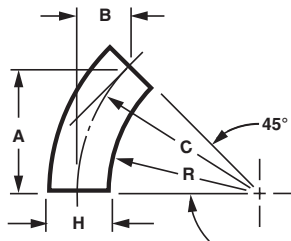
45° Vertical Elbow Outside [40] & Inside [4I]



Outside (40)



Inside (4I)



Radius - R	H Dim.	A Dim.	B Dim.	C Dim.
12" (305mm)	4 1/4" (108mm)	10" (254mm)	4 1/8" (105mm)	14 1/8" (359mm)
	5 1/4" (133mm)	10 3/8" (264mm)	4 1/4" (108mm)	14 5/8" (372mm)
	6 1/4" (159mm)	10 3/4" (273mm)	4 1/2" (114mm)	15 1/8" (384mm)
24" (610mm)	4 1/4" (108mm)	18 1/2" (470mm)	7 5/8" (194mm)	26 1/8" (664mm)
	5 1/4" (133mm)	18 7/8" (480mm)	7 7/8" (200mm)	26 5/8" (676mm)
	6 1/4" (159mm)	19 1/4" (489mm)	8" (203mm)	27 1/8" (689mm)
36" (914mm)	4 1/4" (108mm)	27" (686mm)	11 1/8" (283mm)	38 1/8" (969mm)
	5 1/4" (133mm)	27 3/8" (695mm)	11 3/8" (289mm)	38 5/8" (981mm)
	6 1/4" (159mm)	27 5/8" (702mm)	11 1/2" (292mm)	39 1/8" (994mm)
	7 1/4" (184mm)	8" (711mm)	11 5/8" (295mm)	39 5/8" (1007mm)

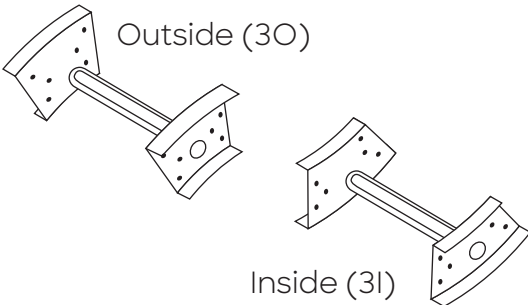
Example: 238-1240-12

Note: Use Adjustable Connectors for odd angles. Nominal 9" rung spacing maintained through centerline of all fittings.

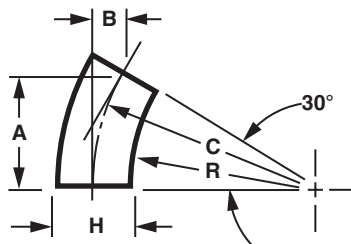
30° Vertical Elbow Outside [30] & Inside [3I]



Outside (30)



Inside (3I)

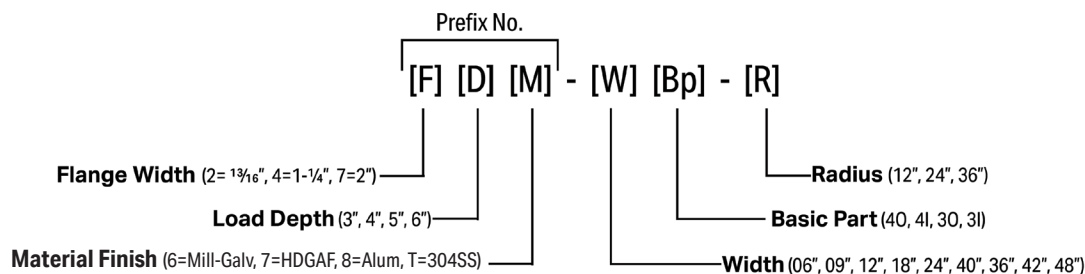


Radius - R	H Dim.	A Dim.	B Dim.	C Dim.
12" 305mm)	4 1/4" (108mm)	7 1/8" (181mm)	1 7/8" (48mm)	14 1/8" (359mm)
	5 1/4" (133mm)	7 3/8" (187mm)	2" (51mm)	14 5/8" (372mm)
	6 1/4" (159mm)	7 5/8" (194mm)	2" (51mm)	15 1/8" (384mm)
24" 610mm)	4 1/4" (108mm)	13 1/8" (334mm)	3 1/2" (89mm)	26 1/8" (664mm)
	5 1/4" (133mm)	13 3/8" (340mm)	3 5/8" (92mm)	26 5/8" (676mm)
	6 1/4" (159mm)	13 5/8" (346mm)	3 3/8" (92mm)	27 1/8" (689mm)
36" 914mm)	4 1/4" (108mm)	19 1/8" (486mm)	5 1/8" (130mm)	38 1/8" (969mm)
	5 1/4" (133mm)	19 3/8" (492mm)	5 1/4" (133mm)	38 5/8" (981mm)
	6 1/4" (159mm)	19 5/8" (499mm)	5 1/4" (133mm)	39 1/8" (994mm)
	7 1/4" (184mm)	19 7/8" (505mm)	5 3/8" (137mm)	39 5/8" (1007mm)

Example: 238-1230-12

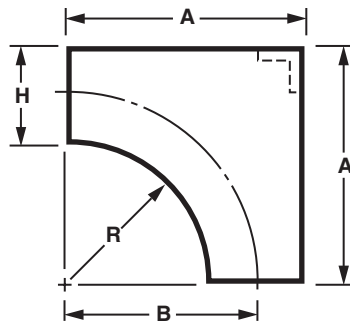
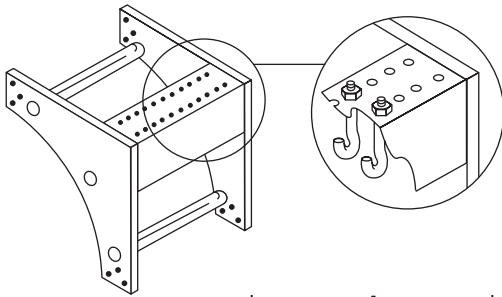
Note: Use Adjustable Connectors for odd angles. Nominal 9" rung spacing maintained through centerline of all fittings.

See Page 24
for Electrical
Grounding Chart



Ladder Cable Tray System

90° Vertical Cable Support Elbow [SR]



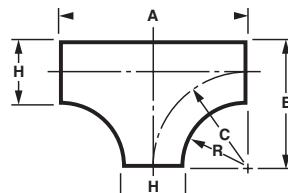
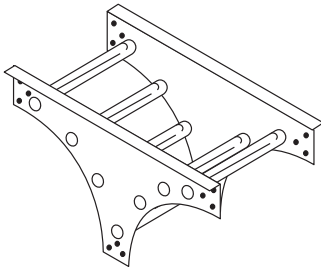
Radius - R	H Dim.	A Dim.	B Dim.
12" (305mm)	4 1/4" (108mm)	16 1/4" (413mm)	14 1/8" (359mm)
	5 1/4" (133mm)	17 1/4" (438mm)	14 5/8" (371mm)
	6 1/4" (159mm)	18 1/4" (464mm)	15 1/8" (384mm)
	7 1/4" (814mm)	19 1/4" (489mm)	15 5/8" (397mm)
24" (610mm)	4 1/4" (108mm)	28 1/4" (718mm)	26 1/8" (664mm)
	5 1/4" (133mm)	29 1/4" (743mm)	26 5/8" (676mm)
	7 1/4" (814mm)	31 1/4" (794mm)	27 5/8" (702mm)
36" (914mm)	4 1/4" (108mm)	40 1/4" (1022mm)	38 1/8" (968mm)
	5 1/4" (133mm)	41 1/4" (1048mm)	38 5/8" (981mm)
	6 1/4" (159mm)	42 1/4" (1073mm)	39 1/8" (994mm)
	7 1/4" (814mm)	43 1/4" (1099mm)	39 5/8" (1006mm)

Example: 238-12SR-12

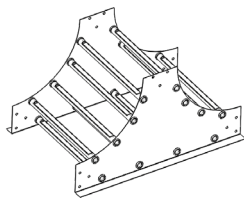
Note: Use Adjustable Connectors for odd angles. Nominal 9" rung spacing maintained through centerline of all fittings.

Vertical Tee - Down [VT] & Up [OT]

Vertical Tee - Down (VT)



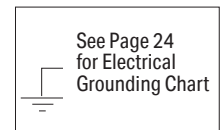
Vertical Tee - Up (OT)



Radius - R	H Dim.	A Dim.	B Dim.
12" (305mm)	4 1/4" (108mm)	16 1/4" (413mm)	14 1/8" (359mm)
	5 1/4" (133mm)	17 1/4" (438mm)	14 5/8" (371mm)
	6 1/4" (159mm)	18 1/4" (464mm)	15 1/8" (384mm)
	7 1/4" (814mm)	19 1/4" (489mm)	15 5/8" (397mm)
24" (610mm)	4 1/4" (108mm)	28 1/4" (718mm)	26 1/8" (664mm)
	5 1/4" (133mm)	29 1/4" (743mm)	26 5/8" (676mm)
	7 1/4" (814mm)	31 1/4" (794mm)	27 5/8" (702mm)
36" (914mm)	4 1/4" (108mm)	40 1/4" (1022mm)	38 1/8" (968mm)
	5 1/4" (133mm)	41 1/4" (1048mm)	38 5/8" (981mm)
	6 1/4" (159mm)	42 1/4" (1073mm)	39 1/8" (994mm)
	7 1/4" (814mm)	43 1/4" (1099mm)	39 5/8" (1006mm)

Example: 238-12VT-12

Note: Use Adjustable Connectors for odd angles. Nominal 9" rung spacing maintained through centerline of all fittings.



Prefix No. [F] [D] [M] - [W] [Bp] - [R]

Flange Width (2= 1 3/16", 4= 1-1/4", 7= 2")

Load Depth (3", 4", 5", 6")

Material Finish (6=Mill-Galv, 7=HDGAF, 8=Alum, T=304SS)

Radius (12", 24", 36")

Basic Part (SR, VT, OT)

Width (06", 09", 12", 18", 24", 40", 36", 42", 48")

Connector Plates

Connector Plates (splice plates) are made of 11 Gauge Steel and are furnished with 3/8"-16 spline bolts & flange nuts unless otherwise specified. Hole patterns match corresponding tray. Three-hole pattern illustrated.

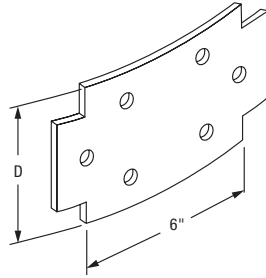
Add -SS for 304 Stainless Steel Hardware and -S1 for 316 Stainless Steel Hardware. Standard hardware is EG.

*HDGAF connector plates are used with Mill-Galv and HDGAF Systems. Mill-Galv connector plates are not available.

Universal Curvilinear Connector [RC]

Load Depth	Finish	Basic No.
3" = 3	7 (HDGAF)*	-02RC
4" = 4	8 (Alum.)	
5" = 5	T (304SS)	
6" = 6		

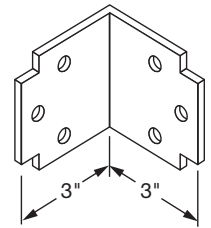
Example: 38-02RC for 3" load depth, Alum, universal curvilinear connector
Note: Sold in pairs.



90° Angle Connector [CA]

Load Depth	Finish	Basic No.
3" = 3	7 (HDGAF)*	-02CA
4" = 4	8 (Alum.)	
5" = 5	T (304SS)	
6" = 6		

Example: 38-02CA for 3" load depth, Alum 90° angle connector
Note: Sold in pairs..

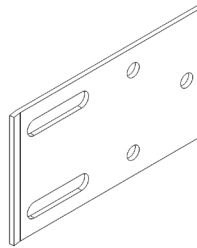


Expansion Connector [CE]

- 3/8"-16 cap screws & Nylok nuts furnished and 3/8"-16 spline bolts & flange nuts furnished

Load Depth	Finish	Basic No.
3" = 3	7 (HDGAF)*	-02CE
4" = 4	8 (Alum.)	
5" = 5	T (304SS)	
6" = 6		

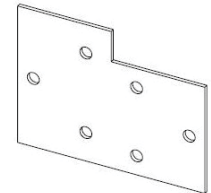
Example: 38-02CE for 3" load depth, Alum expansion connector
Note: Sold in pairs.. Bonding jumpers required and are sold separately.



Stepdown Connector [CD]

Load Depth	Finish	Basic No.	Load Depth 2	Finish 2
4" = 4	7 (HDGAF)*	-02CD	3" = 3	7 (HDGAF)*
5" = 5	8 (Alum.)		4" = 4	T (304SS)
6" = 6	T (304SS)		5" = 5	

Example: 48-02CD-38 for 4" to 3" load depth, Alum, stepdown connector

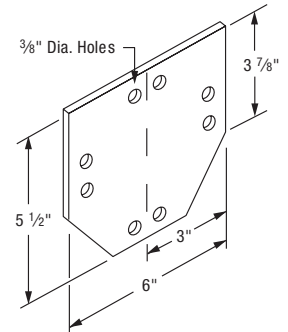


Mid-Span Splice Plate [RC]

Catalog #: 58-02RC-MID

- For use with 20C+ systems

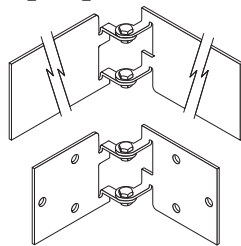
Note: Sold in pairs..



Horizontal Adjustable Connector [CH]

Load Depth	Finish	Basic No.
3" = 3	7 (HDGAF)*	-02CH
4" = 4	8 (Alum.)	
5"/6" = 5	T (304SS)	

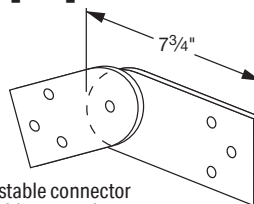
Example: 38-02CH for 3" load depth, Alum, horizontal adjustable connector
Note: Sold in pairs.. Bonding jumpers required and are sold separately.



Vertical Adjustable Connector [CV]

Load Depth	Finish	Basic No.
3"/4" = 3	7 (HDGAF)*	-02CV
5"/6" = 5	8 (Alum.)	
	T (304SS)	

Example: 38-02CV for 3" load depth, Alum, vertical adjustable connector
Note: Sold in pairs.. Bonding jumpers required and are sold separately.

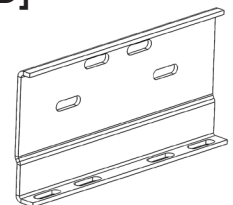


Mid-Span Expansion Plate [CE-MID]

Catalog #: 58-02CE-MID

- For Use with 5" Load Depth Systems

Note: Sold in pairs.

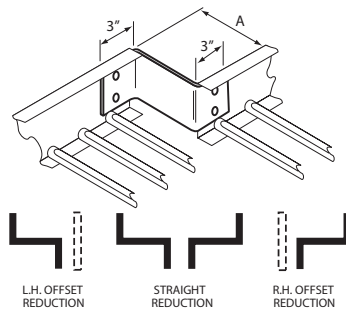


Ladder Cable Tray System

Connector Plates

Reducing Connector [CO]

- 12 Gauge Steel, 0.125" Aluminum
- For offset reductions - use 1 of above with standard connector plate
- For straight reductions- use 2 (of 1/2 reduction dim.). 3/8" -16 spline bolts and flange nuts furnished



Example: 38-03CO for 3" load depth, aluminum, 3" Reducer Connector

Typical Use: 9" to 6", or use 2" for 12" to 6", etc.

Note: Not sold in pairs

Catalog

Load Depth	Finish (Ladder)	Basic Number	A Dim.
3"	6 (Mill-Galv.)	-30CO	30" 762mm
4"	7 (HDGAF)	-27CO	27" 686mm
5"	8 (Alum.)	-24CO	24" 610mm
6"	T (304SS)	-21CO	21" 533mm
		-18CO	18" 457mm
		-15CO	15" 381mm
		-13CO	13 1/2" 343mm
		-12CO	12" 305mm
		-10CO	10 1/2" 267mm
		-09CO	9" 229mm
		-07CO	7 1/2" 191mm
		-06CO	6" 152mm
		-04CO	4 1/2" 114mm
		-03CO	3" 76mm
		-01CO	1 1/2" 38mm

Hardware

Material/ Finish

Electro-galvanized finish standard. Other finishes available; consult factory.

Use following suffix when applicable - use only where indicated.

- **No Suffix** Electro-galvanized carbon steel only
- **-SS** 304 Stainless Steel
- **-S1** 316 Stainless Steel (check factory for availability)

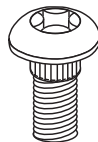
Example: 5003-1-S1, 3/8" x 1 1/2" hex head bolt, 316 stainless steel

Connector Hardware

(Case-hardened steel electro-galvanized)

Catalog # 5003-1

- 3/8" - 16 x 1" spline bolt



Catalog # 5009-1

- 3/8" - 16 hex-flanged nut with serrated washer face



Cover Screw [EM]

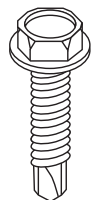
Catalog # EM-CC (electro-galv. steel)

Catalog # EM-CC-SS (stainless steel)

No. 10 x 5/8" long, self drilling-self tapping hex head plated steel screw.

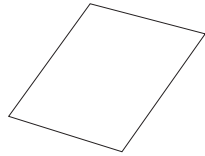
Suggested spacing:

- Indoor: 8 per 12'
- Outdoor: 10 per 12'

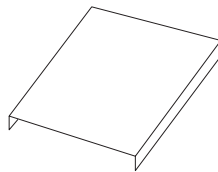


Covers - Ladder

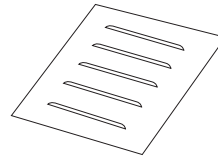
Covers for straight sections shown. Standard Fitting Covers are not NF for HDG systems as NF may warp in the HDG process. Aluminum covers are fabricated from 0.040 aluminum AA-3150-H14; steel covers are fabricated from 20 gauge ASTM A-653-G90 CQ, mill-galvanized steel.



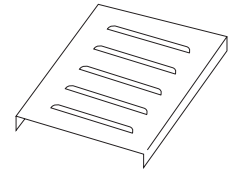
NF - Flat Solid



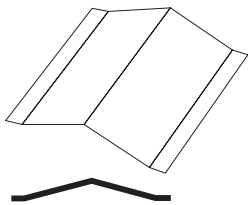
FS - Flanged Solid
w/ 3/8" Flange



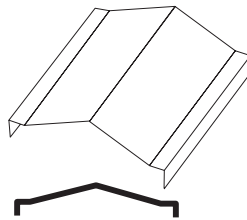
NL - Flat Louvered



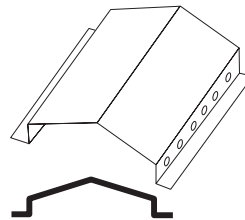
FL - Flanged Louvered
w/ 3/8" Flange



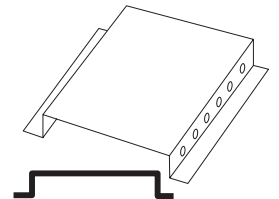
PS - Peaked Solid
(suffix height)



PF - Peaked Flanged
Solid w/ 3/8" Flange
(suffix height)



PH - Peaked Hat Solid
PV - Peaked Hat Vent
(suffix height)



HS - Hat Solid
HV - Hat Vent
(suffix height)



Ladder Cable Tray System

Covers - Ladder

Note: Use EM-CC Cover Screws (see pg. 43) to attach PH, PV, HS & HV covers.

Hot dip covers - straights only 6'

Cover Catalog # - Straight Sections

Type*	Flange	Finish	Basic No. Width	Length	Height**
NF, FS	2" - 1 $\frac{1}{16}$ "	6 - Mill-Galv.	-06SL = 6" (152mm)	-06'	-2*
NL, FL	4" - 1 $\frac{1}{4}$ "	7 - HDGAF	-09SL = 9" (229mm)	-10'	
PS, PF	7" - 2"	8 - Alum.	-12SL = 12" (305mm)	-12'	
PH, PV		T - 304SS	-18SL = 18" (457mm)		
HS, HV			-24SL = 24" (610mm)		
			-30SL = 30" (762mm)		
			-36SL = 36" (914mm)		

*NF, FL, and PS covers are not available in HDGAF

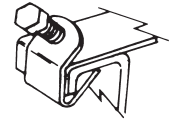
**Peak and hat only, 2 height standard. Consult factory for other heights.

Example: NL46-09SL-10 is a flat louvered mill-galvanized steel cover for a 9" wide mill-galvanized ladder 10' long with a 1 $\frac{1}{4}$ " flange.

Stainless Steel Cover Clip [CCS-SS]

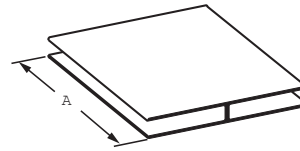
- 1/4" - 28 stainless steel cone point machine screw. Use with any width tray and cover
- Indoor use only
- Suggest spacing 6' max

Not sold in pairs.



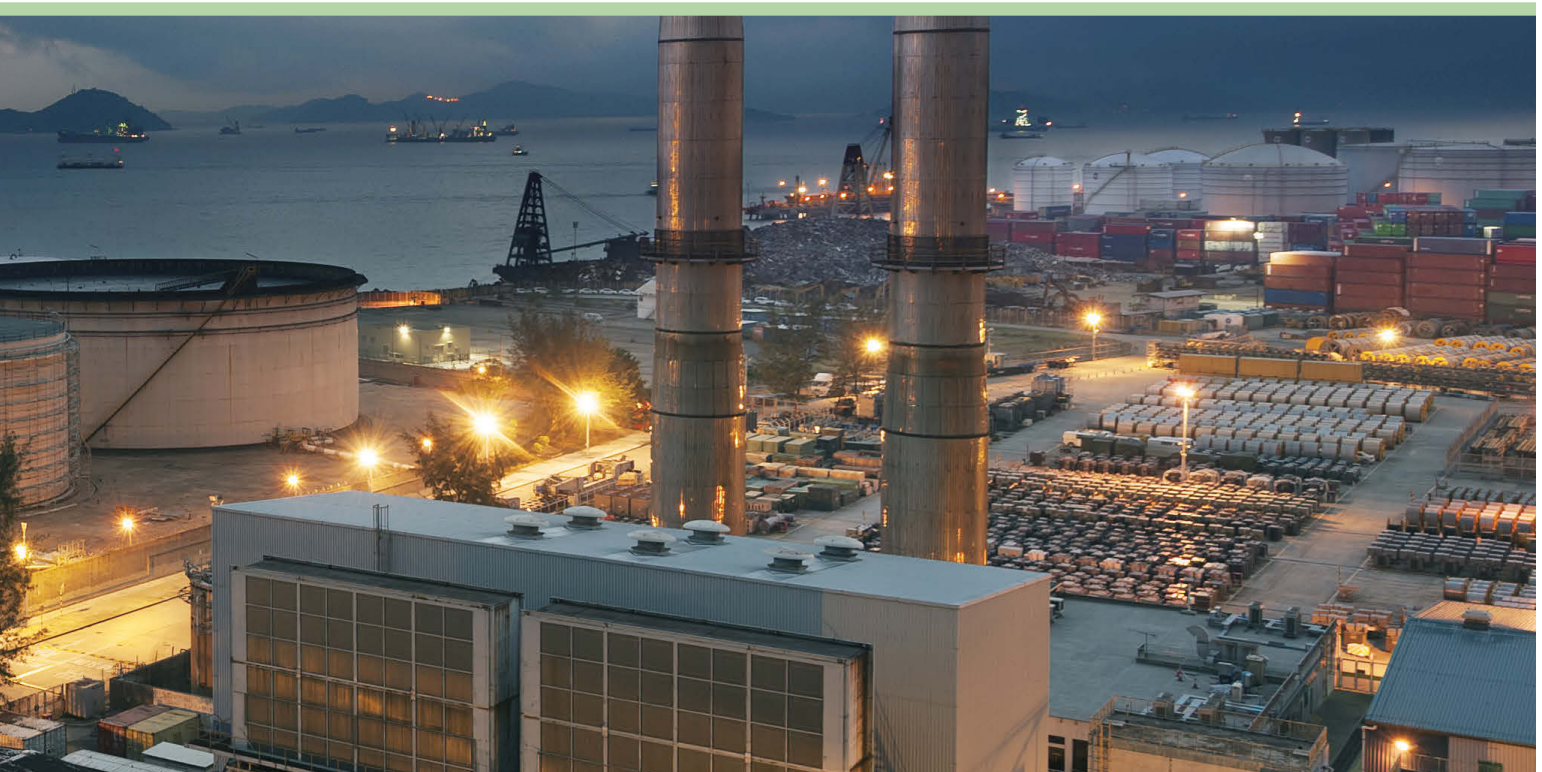
Joint Plate

- Joint plate is black PVC and is offered in 10' lengths to be field cut to desired length, or in pre-cut lengths for specified covers
- JP-120 is joint plate in 10' lengths
- Joint plate for specified covers is specified as follows



Tray Width	Flange Type
JP-06 = 6" (152mm)	-2 = 1 $\frac{1}{16}$ "
JP-09 = 9" (229mm)	-4 = 1 $\frac{1}{4}$ "
JP-12 = 12" (305mm)	-7 = 2"
JP-18 = 18" (457mm)	
JP-24 = 24" (610mm)	
JP-30 = 30" (762mm)	
JP-36 = 36" (914mm)	

Example: JP-06-2 is a joint plate for 6" wide tray with a 1 $\frac{1}{16}$ " flange.

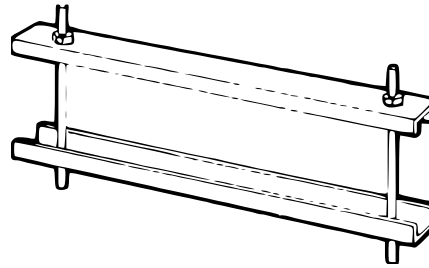


Cover Accessories - Ladder

Double Clamp Connector [DC]

For all covers except hat & peak type.
Furnished with:

- (2) 1/4"-20 all-thread rods
- (4) hex nuts, flat washers, and lock washers
- Suggested spacing:
Indoor: 2 per 12'
Outdoor: 3 per 12'
High Wind: 5 per 12'



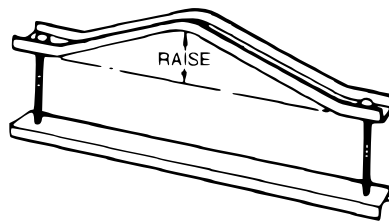
Catalog

Flange	Load Depth	Finish	Width	Type
2=1 ³ / ₁₆ "	3"	6=Mill-Galv.	-06	DC
4=1 ¹ / ₄ "	4"	7=HDGAF	-09	
7=2"	5"	8=Alum.	-12	
	6"	T=304SS	-18	
			-24	
			-30	
			-36	

Example: 238-12DC for 3" load depth, 1³/₁₆" flange, aluminum Double Clamp Connector

Peak Cover Connector [PC]

- Suggested spacing:
Indoor: 2 per 12'
Outdoor: 3 per 12'
High Wind: 5 per 12'
- Note: for PS & PF Covers



Catalog

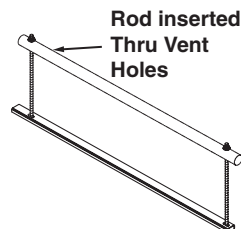
Flange	Load Depth	Finish	Width	Type	Raise*
2= 1 ³ / ₁₆ "	3"	6=Mill-Galv.	-06	PC	-2"
4=1 ¹ / ₄ "	4"	7=HDGAF	-09		
7=2"	5"	8=Alum.	-12		
	6"	T=304SS	-18		
			-24		
			-30		
			-36		

*2 standard raise. Consult factory for other peak heights.

Example: 238-12PC-2 for 3" load depth, 1³/₁₆" flange, aluminum 12" wide, Peak Cover Connector with 2" peak.

Peak Vent Cover Connector [VC]

- Note: for PV Covers



Catalog

Flange	Load Depth	Finish	Width	Type
2=1 ³ / ₁₆ "	3"	6=Mill-Galv.	-06	
4=1 ¹ / ₄ "	4"	7= HDGAF	-09	
7=2"	5"	8=Alum.	-12	
	6"	T=304SS	-18	VC
			-24	
			-30	
			-36	

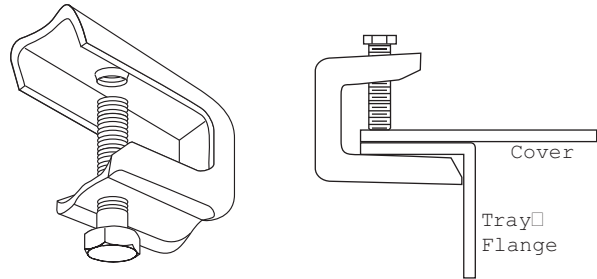
Example: 238-12VC for 3" load depth, 1³/₁₆" flange, 12" wide, Peak Ventilated Cover Connector

Ladder Cable Tray System

Cover Accessories - Ladder

Electro-Galv. Steel Cover Clip [CCS]

- Use with any width tray
- Not sold in pairs
- Indoor use only
- Suggest spacing 6' max.



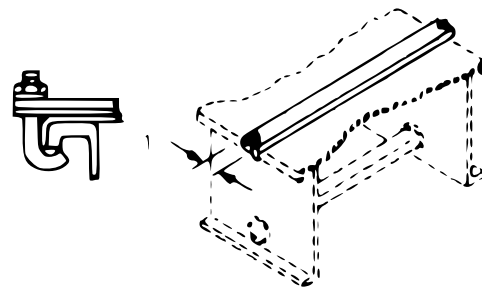
Cover Connector [CC]

- Note: For all covers except hat & peak type

Catalog

Flange	Finish	Width	Type
2=1 ³ / ₈ "	6=Mill-Galv.	-06	CC
4=1 ¹ / ₄ "	7=HDGAF	-09	
7=2"	8=Alum.	-12	
	T=304SS	-18	
		-24	
		-30	
		-36	

Example: 28-12CC for Aluminum, 12" wide Cover Connector



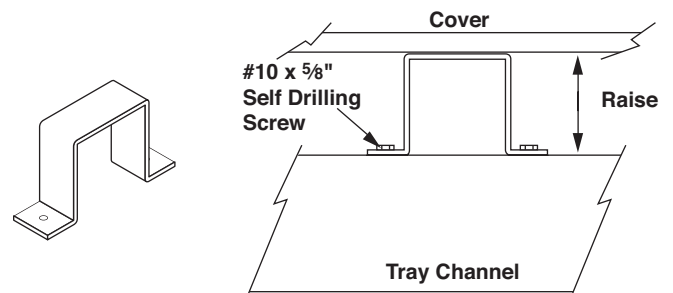
Elevated Cover Connectors [EM-CC]

- Includes:
 - (3) #10 x 5/8" Self drilling screws
- Suggested spacing:
 - Indoor: 2 per 12'
 - Outdoor: 3 per 12'
 - High Wind: 5 per 12'

Catalog

Finish	Type	Raise*
6=Mill-Galv.	EM-CC	-1
7=HDGAF		-2
8=Alum.		-3
T=304SS		

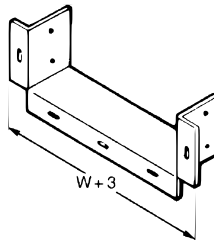
Example: 8-EM-CC-2 for aluminum hot dipped galvanized, Elevated Cover Connector with a 2" raise



Accessories - Ladder

Box Connector [CB]

- 14 Gauge Steel, .080 Aluminum
- Note: ¼"-20 carriage bolts, flat washers, hex nuts furnished



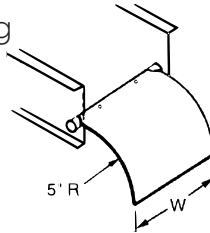
Catalog

Load Depth	Finish	Width
3"	6 (Mill-Galv.)	-06CB = 6 (152mm)
4"	7 (HDGAF)	-09CB = 9 (229mm)
5"	8 (Alum.)	-12CB = 12 (305mm)
6"	T (304SS)	-18CB = 18 (457mm)
		-24CB = 24 (610mm)
		-30CB = 30 (762mm)
		-36CB = 36 (914mm)

Example: 38-12CB for 3" load depth, aluminum, 12" wide, Box Connector.

Drop Out [DO]

- 14 Gauge Steel, .080 Aluminum
- Note: (2) #10 x 5/8" self tapping screws furnished



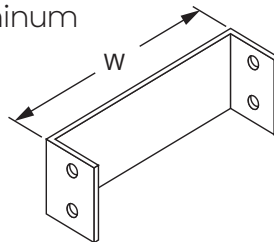
Catalog

Basic Finish	Width
6 (Mill-Galv.)	-06DO = 6" (152mm)
7 (HDGAF)	-09DO = 9" (229mm)
8 (Alum.)	-12DO = 12" (305mm)
T (304SS)	-18DO = 18" (457mm)
	-24DO = 24" (610mm)
	-30DO = 30" (762mm)
	-36DO = 36" (914mm)

Example: 8-12DO for aluminum, 12" wide, Drop Out.

Blind End [BE]

- 22 Gauge Steel, .040 Aluminum
- Note: 3/8"-16 spline bolts and flange nuts furnished



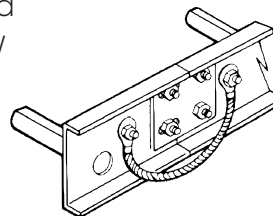
Catalog

Load Depth	Finish	Width
3"	6 (Mill-Galv.)	-06BE = 6" (152mm)
4"	7 (HDGAF)	-09BE = 9" (229mm)
5"	8 (Alum.)	-12BE = 12" (305mm)
6"	T (304SS)	-18BE = 18" (457mm)
		-24BE = 24" (610mm)
		-30BE = 30" (762mm)
		-36BE = 36" (914mm)

Example: 38-12BE for 3" load depth, aluminum, 12" wide Blind End.

Bonding Jumper [CBJ]

- Note: No hardware supplied
- For hardware kit add -HDW
- Ex: CBJ-C-HDW includes
 - 2ea CBJ-C
 - 4ea 5003-1
 - 4ea 5009-1



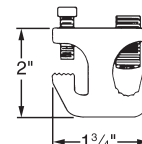
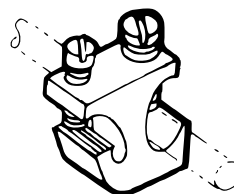
Catalog #	Dimensional Data	Amperes as Equipment Ground
CBJ-C	AWG 1/0 copper wire 15 1/2" long overall	800 amperes
CBJ-4C	AWG 4 copper wire 15 1/2" long overall	1,600 amperes
CBJ-250C	250 MCM copper wire 15 1/2" long overall	2,000 amperes

Cable Tray Ground Clamp [9156]

- Extruded Alum. with Electro-galvanized Hex Head Screws
- Capacity: #6 AWG to 250 kcmil

UL Listed E-24264

Certified File No. LR9795

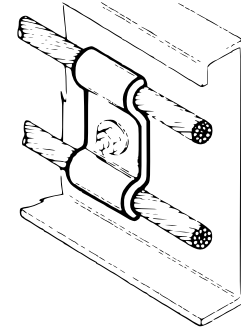


Ladder Cable Tray System

Accessories - Ladder

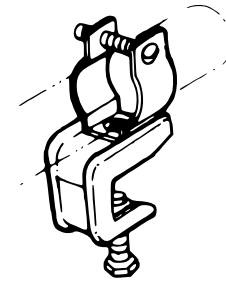
Ground Cable Retainer Clamp

Catalog #	Capacity	Metal & Finish	Dimensions
9056-EP	1/O 2/O 3/O	Electro-Galv. Steel	1" w x 2" long
9057-EP	4/O 250 MCM		1" w x 2 ³ / ₈ " long
9056-SS	1/O 2/O 3/O	Stainless Steel	1" w x 2" long
9057-SS	4/O 250 MCM		1" w x 2 ³ / ₈ " long



Conduit Clamp Bracket

Catalog #	Size-Rigid	Size-EMT
CCB-050	3/8" to 1/2"	1/2"
CCB-075	3/4"	3/4"
CCB-100	1"	1"
CCB-125	-	1 ¹ / ₄ "
CCB-150	1 ¹ / ₄ "	1 ¹ / ₂ "
CCB-200	2"	2"

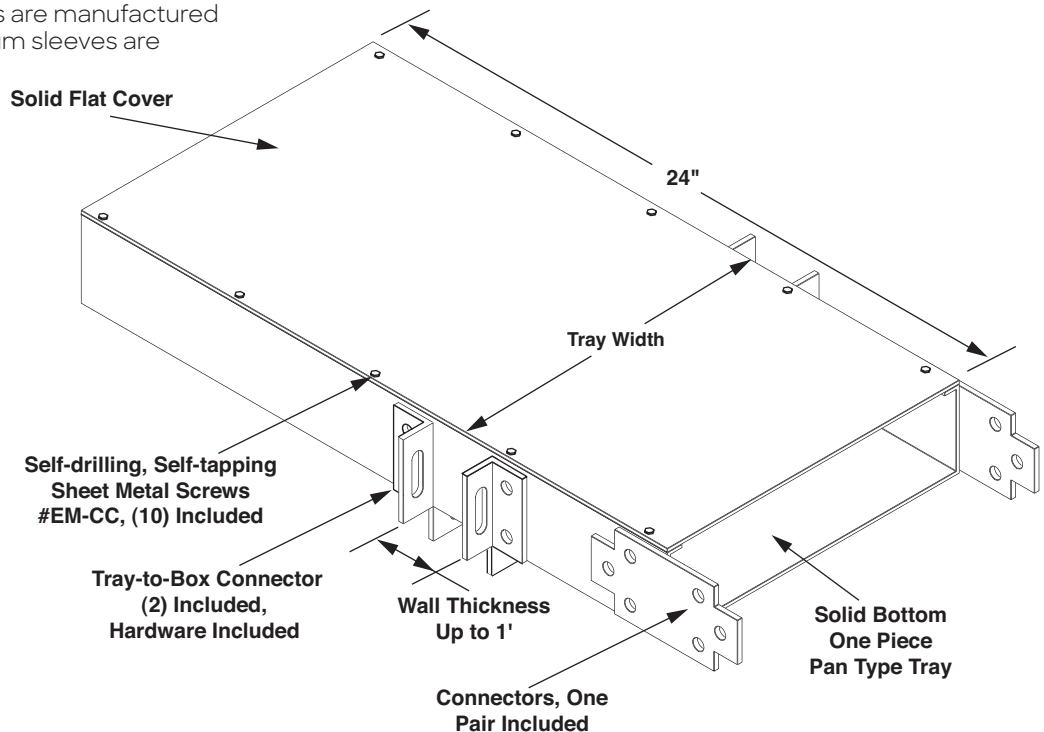


Wall Penetrating Sleeve Assembly

Item Code SS89042(W)*

- W = Tray Width
- *Fitting 3-Digit Prefix

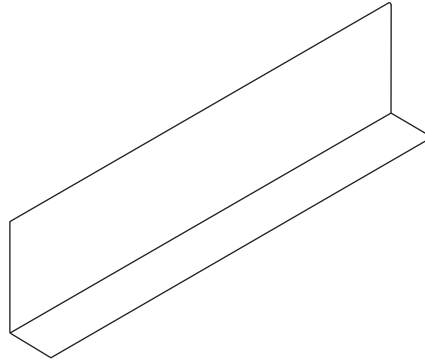
Note: Standard penetration sleeves are manufactured from mill-galvanized steel. Aluminum sleeves are available upon request.



Barrier Strips - Ladder

Universal Aluminum Barrier Strip - Straight Section [SB]

- Furnished with (8) self tapping screws



Catalog

Load Depth	Finish	Basic No.	Length
3"	A (Alum.)	-01SB	10
4"		-01SB	12
5"			
6"			

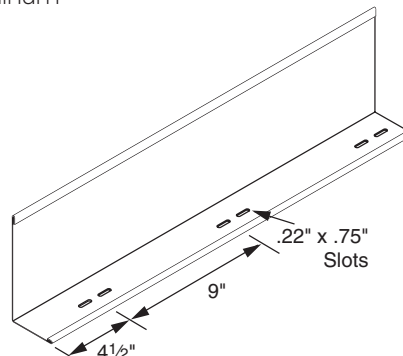
Example: 3A-01SB-12 for 3" load depth, aluminum straight barrier, 12' long.

Barrier Strip - Straight Section [SB]

- Furnished with (4) barrier strip clamps and necessary hardware. (SB-HDW)

Note: U-bolts provided with SB-HDW are EG Hardware only

* Long lead time item - See Universal aluminum barrier strip above



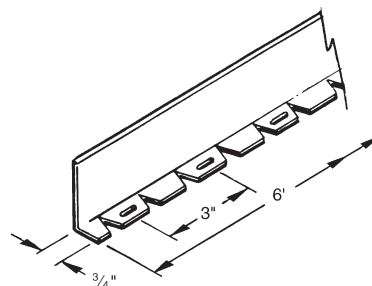
Catalog

Load Depth	Finish	Basic No.	Length
3"	6 (Mill-Galv.)	-01SB	10
4"	7 (HDGAF)	-01SB	12
5"	8 (Alum.) *		
6"	T (304 SS)		

Example: 46-01SB-12 for 4" load depth, mill-galvanized straight barrier, 12' long.

Barrier Strip - Horizontal Fitting [FB]

- Furnished with (4) barrier strip clamps and necessary hardware



Catalog

Load Depth	Finish	Basic No.	Length
3"	6 (Mill-Galv.)	-01FB	06
4"	7 (HDGAF)		
5"	8 (Alum.)		
6"	T (304 SS)		

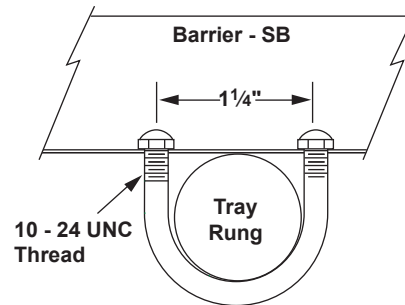
Example: 38-01FB-06 for 3" load depth, aluminum fitting barrier, 6' long.

Ladder Cable Tray System

Barrier Strips - Ladder

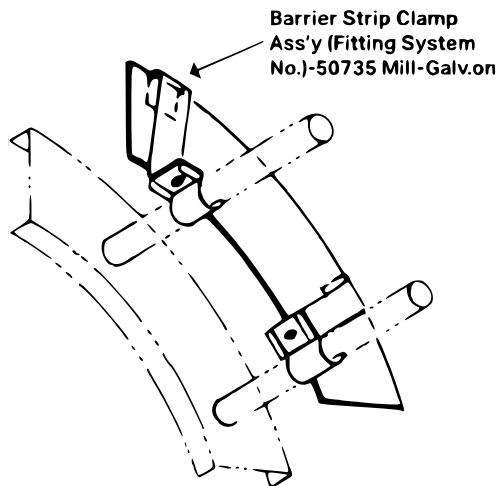
Barrier Strip Clamp [SB-HDW]

- Includes: (4) U-Bolt 707981505
(8) Acorn Nuts 707671500



Barrier Strip Vertical Elbow Outside [OB] & Inside [IB] (OB shown)

- Furnished with sufficient clamp assemblies for installation. Additional clamp assemblies may be ordered separately
- IB and OB fitting hardware available in EG and SS only

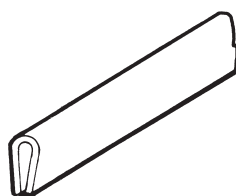


Catalog

Load Depth	Finish	Bend	Basic No.	Radius
3"	6 (Mill-Galv.)	90°	OB = Outside	12" (305mm)
4"	7 (HDGAF)	60°	IB = Inside	24" (610mm)
5"	8 (Alum.)	45°		36" (914mm)
6"	T (304 SS)	30°		

Example: 38-900B-12 for 3" load depth, aluminum 90° outside vertical barrier with 12 radius.

Nylon Barrier Splice & Protector [BSP-L]



Catalog

Prefix	Length
BSP	-5 (5 Splice) -144 (144 Protector) -1200 (100' Roll)

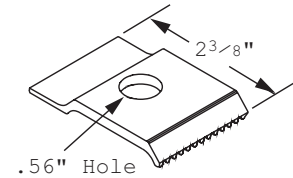
Example: BSP-1200 for 100' roll

Accessories - Ladder

Combination Hold-Down Clamp & Expansion Guide [9131]

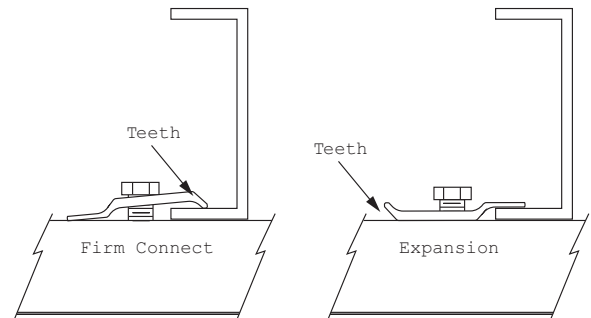
9131-HDW (Complete Hardware Kit)

- Hardware list:
 - (2) Combination hold-down clamp & expansion guide
 - (2) ½" - 13 x 1 ¼" Cap Screw
 - (2) ½" Flat Washer
 - (2) Clamping Nut (Strut Nut)



Catalog #	Material
9131	Hot-Dipped Galvanized
9131L	316 Type Stainless Steel
9131A	Aluminum

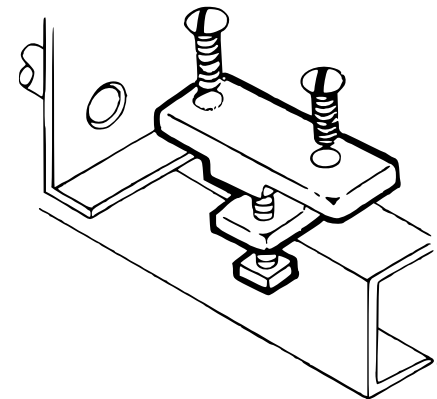
Hardware purchased separately to suit support system.



Combination Hold-Down / Expansion Guide [9053] (LADDER ONLY)

- Universal Guide: for either side of ladder. Use when tray is mounted on I-Beams or channels
- No drilling required
- Note: Use set screws for firm hold down

Catalog #	Finish
6-9053	Hot-Dipped Galvanized
8-9053	Aluminum

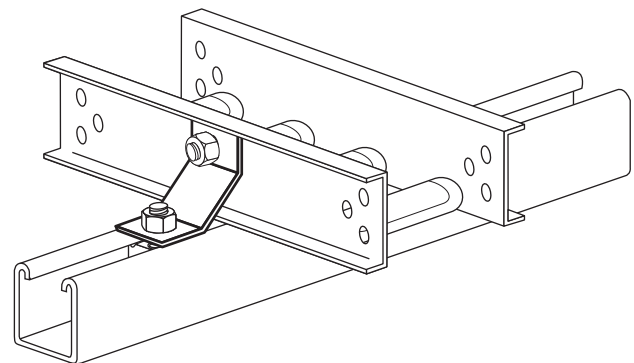


Seismic Hold-Down [9132]

Note: Preferred for seismic applications or other bolted connections.

Catalog #	Material
9132	Mill-Galvanized
9133	Stainless Steel

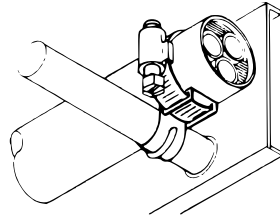
Hardware purchased separately to suit support system.



Ladder Cable Tray System

Accessories - Ladder

Cable Clamp



Galvanized Steel - Part No. GCC

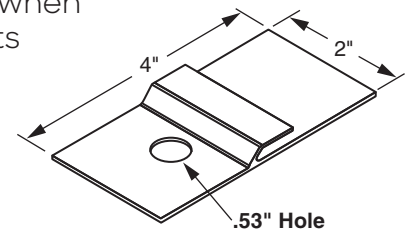
Catalog #	Clamp Min.	Dia. Max.
GCC-300	1	3½"
GCC-400	1	4½"
GCC-450	1	5"
GCC-650	1	7"
GCC-850	1	9"
GCC-100	1	10½"
GCC-115	1	12"
GCC-135	1	14"

Stainless Steel - Part No. SCC

Catalog #	Clamp Min.	Dia. Max.
SCC-150	¾"	1½"
SCC-250	1 ⅝"	2½"
SCC-400	2½"	4"
SCC-450	2 ⅝"	4½"
SCC-600	4¼"	6"

Isolation Pad [9131-IP]

- The Isolation pad provides protection from galvanic corrosion when dissimilar metals are used between trays, clamps, and supports
- Hardware purchased separately

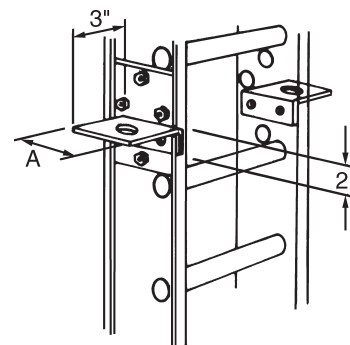


Support Brackets & Tray Hangers - Ladder

Vertical Supports

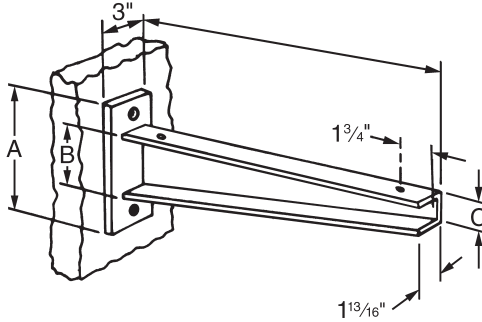
Ladder Supports can be bolted anywhere along the straight runs. They can be bolted directly onto the coupler plates at splices of straight runs and riser fittings, or they can be bolted at any place in the run by field-drilling side rails. Ladder supports are used with either ⅜" or ½" hanger rods. Finish is Hot-Dipped Galvanized.

Catalog #	For Use With
9043-37	4 ¼ Overall Height Side Members
9043	5 ¼ Overall Height Side Members
9025-98	6 ¼ & 7 ¼ Overall Height Side Members



Support Brackets & Tray Hangers - Ladder

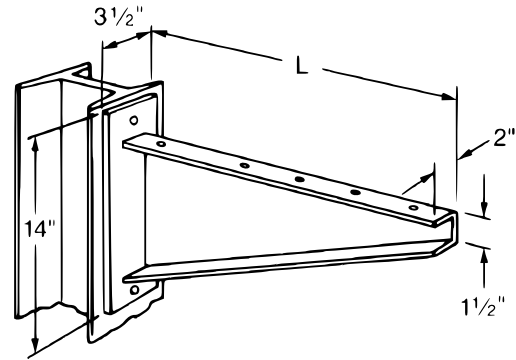
Wall Support Brackets



Catalog #	Ladder Width	Length L	Dimensions			End-Load Rating*
			A	B	C	
9037-12	6"	12 1/4"	10"	6"	2"	2000 lbs
9037-18	12"	18 1/4"	11"	7"	2 1/2"	2000 lbs
9037-24	18"	24 1/4"	11"	7"	2 1/2"	1600 lbs
9037-30	24"	30 1/4"	12"	8"	4"	1300 lbs
9037-36	30"	36 1/4"	12"	8"	4"	1100 lbs
9037-42	36"	42 1/4"	12"	8"	4"	900 lbs

*Uniform load rating is normally twice the end-load rating.
Finish is hot-dip galvanized after fabrication.
Order hardware separately.

Structural Support Bracket



Catalog #	Ladder Width	Length L	End-Load Rating*
9036-31	24"	31 1/4"	2000 lbs
9036-37	30"	37 1/4"	1800 lbs
9036-45	36"	45 1/4"	1500 lbs

*Uniform load rating is normally twice the end-load rating.
For use with Cope Ladder 24" or wider. May be welded or bolted to building steel.
Finish is hot-dip galvanized after fabrication.
Order hardware separately.

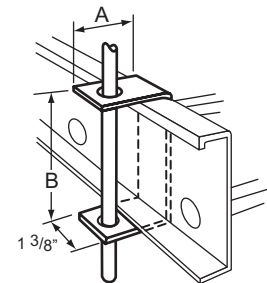
Single Ladder Hangers

- Cope Ladder Hangers are sized according to the side rail height and flange dimensions of various Cope ladders
- The 1 7/32" holes accommodate either 3/8" or 1/2" diameter threaded rod

Catalog

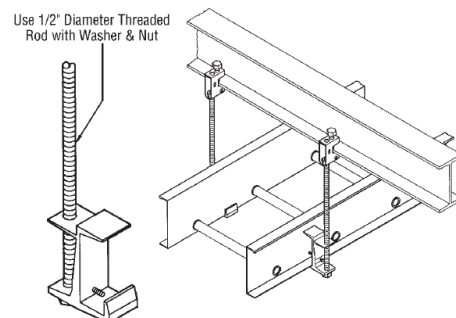
Basic No.	M.G.	Finish H.D.G.	Alum.	Side Rail	A Dim.	B Dim.
9038-	236	237	238	4 1/4" X 1 3/16"	2"	4 5/16"
9038-	246	247	248	5 1/4" X 1 3/16"	2"	5 5/16"
9038-	256	257	258	6 1/4" X 1 3/16"	2"	6 7/16"
9038-	266	267	268	7 1/4" X 1 3/16"	2"	7 7/16"
9038-	436	437	438	4 1/4" X 1 1/4"	2 3/16"	4 7/16"
9038-	446	447	448	5 1/4" X 1 1/4"	2 3/16"	5 5/16"
9038-	456	457	458	6 1/4" X 1 1/4"	2 3/16"	6 7/16"
9038-	466	467	468	7 1/4" X 1 1/4"	2 3/16"	7 7/16"

Order hardware separately.
Finish is Mill-Galv., HDGAF, or Aluminum.



Tray Hangers

- Catalog # 7-HGR1 (Steel)
 - Catalog # 8-HGR1 (Aluminum)
- Sold Individually.



Ladder Cable Tray System

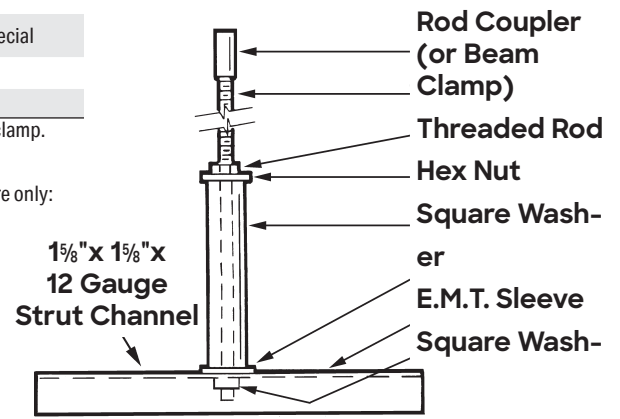
Tray Hangers & Supports - Ladder

Single Rod Hanger Support

Catalog #

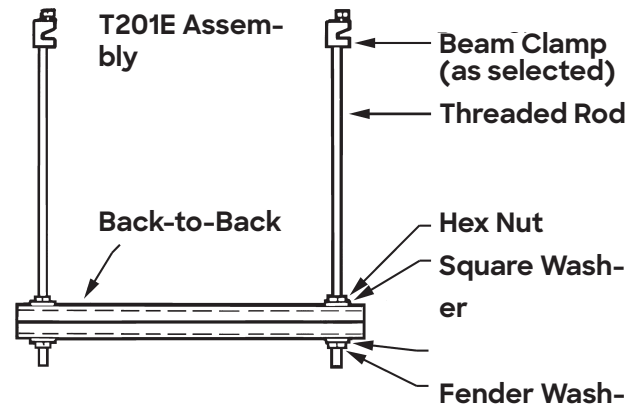
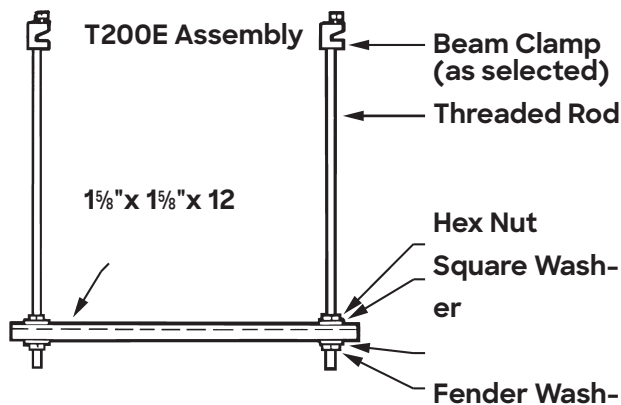
Assy. Type	Channel Length*	Channel Finish**	Rod Diameter	Rod Length	Beam Clamp
P200	14" 356mm	GV (Pre-Galv)	38=3/8 (9.53)	000 - No Rod	A - Bridgeport
	17" 432mm		12=1/2 (12.7)	036 - 36" 914mm	B - P2622
	20" 508mm	HG (Hot Dipped Galv)		072 - 72" 1828mm	O - No Clamp
	26" 661mm			120 - 120" 3048mm	R - Rod Coupler
	32" 813mm			144 - 144" 3658mm	S - Special
	38" 966mm				
	44" 1118mm				

Example: P20020GV12036B is a Single 20" pre-galvanized channel with 1/2" x 36" drop rod and P2622 clamp.
 Note: *Order channel length 8" longer than tray width.
 For example, 44" channel for 36" tray.
 ** Other channel types and finishes available upon request. Contact factory. To order hardware only:
 3/8" - PGV380000
 1/2" - PGV120000



1/2" - PGV120000

Trapeze Hanger Support



Catalog #

Assy. Type	Channel Length*	Channel Finish**	Rod Diameter	Rod Length	Beam Clamp
T200E	16" 407mm	GV (Pre-Galv)	38=3/8" (9.53)	000 - No Rod	A - PS 85
T201E	19" 483mm	HG (Hot Dipped Galv)	12=1/2" (12.7)	036 - 36" 914mm	B - P2622
	22" 559mm			072 - 72" 1828mm	O - No Clamp
	28" 712mm			120 - 120" 3048mm	R - Rod Coupler
	34" 864mm			144 - 144" 3658mm	S - Special
	40" 1017mm				
	46" 1169mm				

Example: T200E22GV12036B is a Single 22" pre-galvanized channel with 1/2" x 36" drop rod and P2622 clamp.

Note: *Order channel length 10" longer than tray width. For example, 46" channel for 36" tray.

** Other channel types and finishes available upon request. Contact factory.

To order hardware only:

3/8" - PGV380000

1/2" - PGV120000

I-Beam Ladder



**Cable Ladder System for Power, Control,
Instrumentation Cable & Pneumatic Tubing**



General & Technical Information

Pictorial Index 59
 Selection Chart: Cope I-Beam Aluminum..... 60

Cope I-Beam Fittings

Overview 62
 Horizontal Elbows 65
 Y Branch (Left, Right, Straight)..... 65
 Adjustable Elbows 65
 Reducers (Straight, Left, Right)..... 65
 Horizontal Tees & Crosses (Standard, Reducing, Expanding) 66
 Vertical Tees (Down, Up, Cross) 66
 Dropout Tee 66
 Dropout Cross..... 66
 Vertical Elbows 67
 90° Vertical Cable Support Elbows (Inside/Outside)..... 67

Dividers

Straight, Horizontal, Vertical Dividers and Hardware..... 68

Covers

Covers 70
 Cover Accessories (Hold down clamps, elevated and peaked cover connectors).... 71

Accessories

Connectors 72
 Bonding and Grounding..... 74
 Hold Down Clamps, Expansion Guides 75
 Rain Hood, Wall Penetration Sleeve 77
 Replacement Rungs, Blind End..... 78
 Drop Out, Roof Support, Hanger Channels, Wall Brackets 79
 Fasteners & Hardware 81

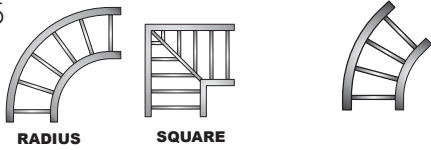


I-Beam Ladder

Ladder Pictorial Index

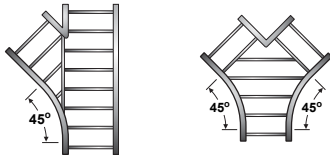
Horizontal Elbows

Page 65



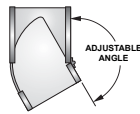
Y Branch

Page 65



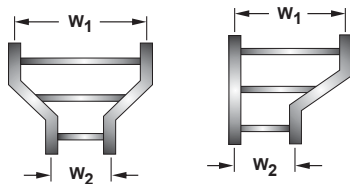
Adjustable Elbows

Page 65



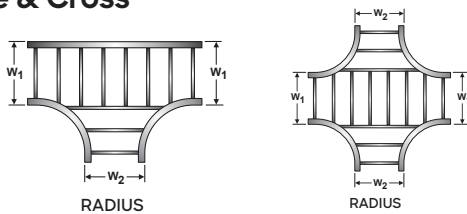
Reducers

Page 65



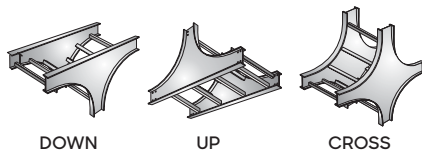
Horizontal Tee & Cross

Page 66



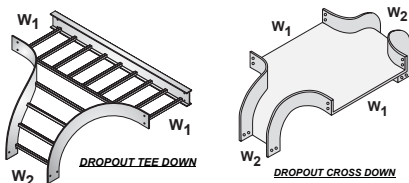
Vertical Tees

Page 66



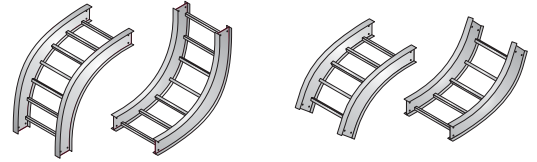
Dropout Tee & Cross

Page 66



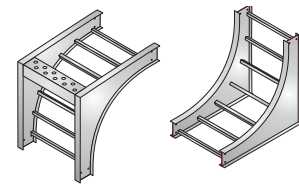
Vertical Elbows

Page 67



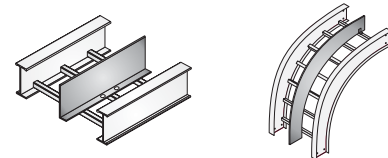
90° Vertical Cable Support Elbow

Page 67



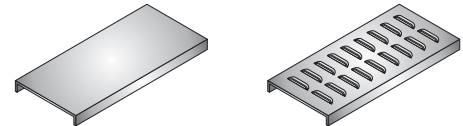
Dividers

Page 68



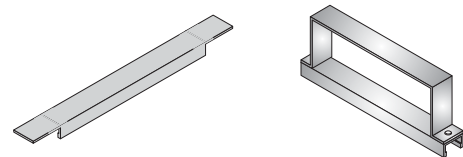
Covers

Page 70



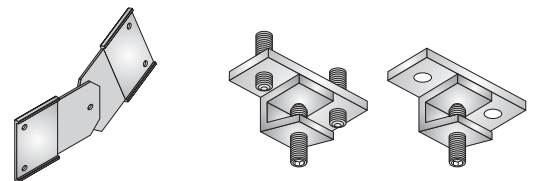
Cover Accessories

Page 71



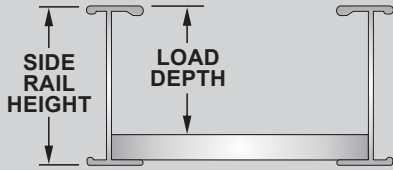
Accessories

Page 72



Cable Tray Straight Sections - Aluminum

Cable Tray Cross-Section

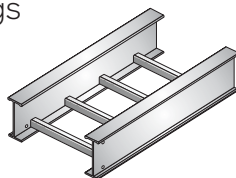


- Extruded aluminum alloy 6063-T6
- Side rails are I-Beam profiles
- Rungs are 1½ square tubes with open slot facing down
- Arc-welded construction
- UL Classified grounding
- UL Certified load capacities
- NEMA, CSA and NEC Compliant
- Necessary Splice Plates with hardware are included with all straight sections and fittings
- Made in the USA

Side Rail Height	Load Depth	NEMA Load Class	NEMA Safe Load Load - Span	CSA Load Class	System Number	Fittings		Standard Tray Length	UL Area	Amp Rating
						Class	Prefix			
4"	3"	12B	81 lbs/ft - 12' span	C	A412B	1	A41	12'	0.60 in ²	1000
		12C	100 lbs/ft - 12' span	D-3M	A412C	1	A41	12', 24'	0.60 in ²	1000
		20A	58 lbs/ft - 20' span	D-6M	A420A	2	A42	12', 20'	1.50 in ²	1600
		20B	85 lbs/ft - 20' span	E-6M	A420B	2	A42	20', 24'	1.50 in ²	1600
5"	4"	12B	78 lbs/ft - 12' span	C	A512B	1	A51	12'	1.00 in ²	1200
		20A	57 lbs/ft - 20' span	D-6M	A520A	2	A52	12', 20'	1.50 in ²	1600
		20B	80 lbs/ft - 20' span	E-6M	A520B	2	A52	20'	1.50 in ²	1600
		20C	115 lbs/ft - 20' span	E-6M	A520C	2	A52	20'	1.50 in ²	1600
6"	5"	12B	89 lbs/ft - 12' span	D-3M	A612B	1	A61	12'	1.00 in ²	1200
		12C	105 lbs/ft - 12' span	D-3M	A612C	1	A61	12'	1.00 in ²	1200
		20A	62 lbs/ft - 20' span	D-6M	A620A	2	A62	12', 20'	1.50 in ²	1600
		20B	80 lbs/ft - 20' span	E-6M	A620B	2	A62	20', 24'	1.50 in ²	1600
		20C	109 lbs/ft - 20' span	E-6M	A620C	2	A62	12', 20', 24'	2.00 in ²	2000
		20C+	104 lbs/ft - 24' span	E-6M	A624C	3	A63	20', 24'	2.00 in ²	2000
7"	6"	20C++	128 lbs/ft - 25' span	E-6M	A620D	3	A63	20', 25', 30'	2.00 in ²	2000
		12C	100 lbs/ft - 12' span	D-3M	A712C	1	A71	12'	1.00 in ²	1200
		20B	81 lbs/ft - 20' span	E-6M	A720B	2	A72	20'	2.00 in ²	2000
		20C	108 lbs/ft - 20' span	E-6M	A720C	2	A72	20', 24'	2.00 in ²	2000
		20C+	111 lbs/ft - 24' span	E-6M	A720D	3	A73	20', 25'	2.00 in ²	2000
8"	7"	20C++	105 lbs/ft - 30' span	E-6M	A720E	3	A73	20', 30'	2.00 in ²	2000
		20C+	121 lbs/ft - 30' span	E-6M	A820D	4	A84	20', 30'	2.00 in ²	2000
		20C++	114 lbs/ft - 40' span	E-6M	A820E	4	A84	30', 40'	2.00 in ²	2000

Standard Ladders & Ventilated/Trof

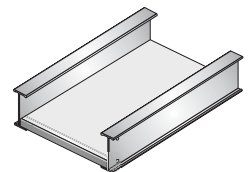
- 1½" Square tubular rungs
- 6", 9", 12" Rung spacings
- 5 Rung spacing for trof
- Rungs have large radius corners
- Optional rung designs available



BOTTOM TYPE	RUNG SPACING
06	6" RUNG SPACING
09	9" RUNG SPACING
12	12" RUNG SPACING
VT	5" RUNG SPACING

Solid Bottoms

- Solid, 0.040" flat sheet on top of ladder rungs on 12" centers
- Bottoms can be located under rungs
- Bottoms can be located on top of and under rungs (double bottom)
- Heavier bottoms available



BOTTOM TYPE	BOTTOM LOCATION
SF	SOLID FLAT BOTTOM ON TOP OF RUNGS
SFU	SOLID FLAT BOTTOM UNDER RUNGS



All Cope aluminum cable trays are classified by Underwriters Laboratories as suitable for use as equipment grounding conductors per NEC 392 and are certified by UL to meet all requirements of CSA Std. C22.2 No. 126. All NEMA and CSA safe load data is based on destruction load tests that were witnessed and certified to be accurate by Underwriters Laboratories.



NEMA and CSA Span/Load Classes

Span/Load Class Designations

Commonly called the Load Class, this defines the load-carrying capability of the tray for a specific support span distance. The design and cost of the cable tray is greatly affected by this designation. In order to determine the most appropriate and economical system, a class should be selected that reflects the actual total working load and support span for each application.

Concentrated Static Loads

Some applications may require the cable tray to support the weight of a single, dead object in addition to the cable loads. Specifications typically require this to be applied at the mid-point of the span between the tray supports, which is the worst-case location. To incorporate this in the tray design the following formula can be used to convert the concentrated static load in pounds to an equivalent uniform load (W) in pounds per foot. That equivalent load can then be combined with the weight of cables, tray contents, and other loads that are also expressed in lbs/ft to determine the total Working Load.

Formula

$$W_e = \frac{2 \times (\text{concentrated static load, lbs})}{\text{support span length, ft}}$$

Note: This calculation is based on the load being applied at the center of the tray in the middle of a rung or bottom. If the specification requires the concentrated static load to be applied on top of one side rail, then the equivalent uniform load will be 2 times the result of this calculation.

Example

A cable tray is to be supported on 20' spans. It shall contain 50 lbs/ft of cables and support 15 lbs/ft of snow load. It is also required to support a 250 pound concentrated static load applied in the center of the tray width. Using the calculation above, the concentrated static load is converted to an equivalent uniform load as follows: $2 \times 250 \text{ lbs} / 20 \text{ ft} = 25 \text{ lbs/ft}$. The Total Working Load will be the combination of all 3 loads, expressed in lbs/ft:

Cables	40 lbs/ft
Snow	+15 lbs/ft
Concentrated Load	+25 lbs/ft
Total Working Load:	80 lbs/ft

Refer to the chart below. With a support span of 20' and a

total working load of 80 lbs/ft, a NEMA Class 20B tray rated at 75 lbs/ft will not be adequate. A NEMA Class 20C tray, rated at 100 lbs/ft, will be required.

Working Load

The total load supported by the cable tray, uniformly distributed. This will be the combined weight of all of the cables or tray contents, any environmental loads (snow, ice, dust) and any concentrated static loads.

Support Span

The maximum distance between the tray supports.

NEMA Load Classes

A number (support span in feet) combined with a letter (load capacity: A=50, B=75 and C=100 Lbs/Ft). Defined in the National Electrical Manufacturers Assoc. NEMA Standard VE1.

CSA Load Classes

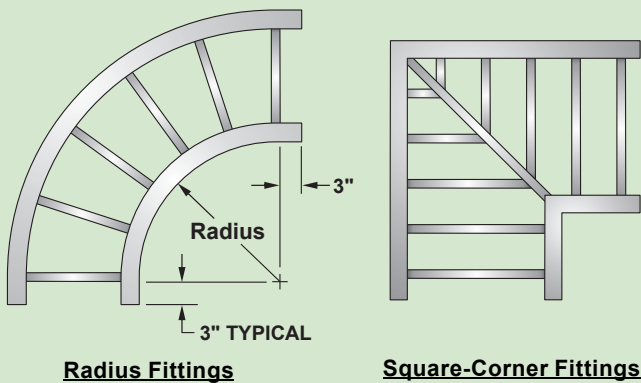
A single letter (A,B,C,D,E) designates the support span and load capacity per Canadian Standards Association CSA Standard C22.2, No. 126.

Span/Load Class Designations Per NEMA Standard VE1 / CSA C22.2 No. 126						
Working Load lbs/ft (kg/m)	Support Span, Feet (Meters)					
	5 (1.5)	8 (2.4)	10 (3.0)	12 (3.6)	16 (4.9)	20 (6.0)
25 (37)	5AA	8AA	10AA	12AA		20AA
45 (67)						D*
50 (74)	5A	8A		12A	16A	20A
65 (97)			C			
75 (112)		8B		12B	16B	E* or 20B
100 (149)		8C		12C	16C	20c
120 (179)			D*			
200 (299)			E*			

* CSA Classes D and E are applicable to both 3.0 and 6.0 meter support spans. The appropriate support span should also be included when specifying these classes (example: D-3M).



I-Beam Ladder



Tangents

All fittings have 3 tangents (flats) at the end of all curved side rails to accommodate splice plate connectors.

Radius

Standard NEMA-VE1 12", 24", and 36" available for all curved fittings. 48" radius and other custom designs are available, consult factory.

Square Corners

90 Degree Horizontal Elbows, Horizontal Tees, and Horizontal Crosses are available with square corners (0" radius). The 6" through 18" square-corner fittings are designed to align with the centerline of 24" square panels of raised-floor systems.

Splice Plates

All elbows are supplied with one pair of standard splice plates with hardware at no charge. WYE fittings and tees include 2 pairs and crosses include 3 pairs with hardware at no charge.

Cable Tray Fittings - Aluminum

Material

All fittings are aluminum with arc-welded construction.

Side Rails

Fitting side rails are I-Beams with overall dimensions similar to straight tray sections.

Rungs and Bottoms

Rung and Bottom designs are identical to similar straight cable tray sections.

FEATURES

SWAGE

I-BEAM

TROF

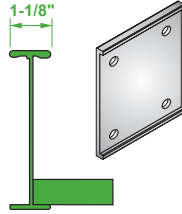
EAGLE BASKET

CHANNEL



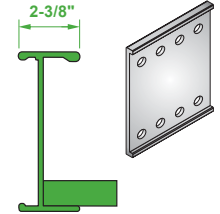
Class 1 Fittings

- NEMA Class 12B & 12C Trays
- 1 1/8" Wide Side Rail Flanges
- 4-Bolt Connector Plates
- 3" Tangents



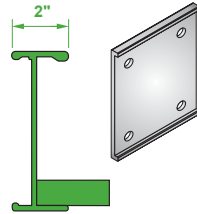
Class 3 Fittings

- NEMA Classes beyond 20C
- 2 3/8" Wide Side Rail Flanges
- 8-Bolt Connector Plates
- 3" Tangents



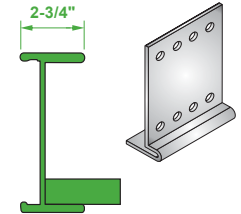
Class 2 Fittings

- NEMA Class 20A, 20B, 20C Trays
- 2" Wide Side Rail Flanges
- 4-Bolt Connector Plates
- 3" Tangents



Class 4 Fittings

- 8 High Long-Span System A820E
- 2 3/4" Wide Side Rail Flanges
- 8-Bolt Wrap-Around Connectors
- 3" Tangents



Catalog #'s for Horizontal and Vertical Elbows, Standard Horizontal Tees, and Crosses

Material A - Aluminum ←

Catalog # Example: **A62 - 09 (*) - 90H24 - 36 - G**

Side Rail Height	Fitting Class	Bottom Type	Optional Rungs and Bottoms	Item Code	Radius	Width 1	Hardware Finish	
4 - 4" High	1 - NEMA Classes 12B & 12C	06 - 6" Rung Spacing	BLANK - Standard Design, No Options	Insert 2 or 3-digit Item Code to specify Fitting type	12 - 12"	06 - 6"	G - Geomet Plated Steel	
5 - 5" High	2 - NEMA Classes 20A, 20B & 20C	09 - 9" Rung Spacing	Insert 2-Digit Bottom Code (See Page 14 -15) to specify optional rungs and bottoms		24 - 24"	09 - 9"	S - Stainless Steel Type 316	
6 - 6" High	3 - NEMA Classes exceeding 20C	12 - 12" Rung Spacing			00 - Square Corners and Adjustable Elbows (HAE)	12 - 12"		18 - 18"
7 - 7" High	4 - 8" High System A820E	VT - Ventilated/Trough			24 - 24"	30 - 30"		36 - 36"
8 - 8" High		SF - Solid Flat Bottom			36 - 36"			
		SFU - Solid Flat Bottom, Under Rungs						

Non-standard lengths and widths are available; consult factory for lead times

Catalog #'s for Reducer Fittings, Reducing and Expanding Tees, Reducing Crosses

Material A - Aluminum ←

Catalog # Example: **A73 - 09 (*) - HTR24 - 36 - 18 - S**

Side Rail Height	Fitting Class	Bottom Type	Optional Rungs and Bottoms	Item Code	Radius	Width W1	Width W2	Hardware Finish	
4 - 4" High	1 - NEMA Classes 12B & 12C	06 - 6" Rung Spacing	BLANK - Standard Design, No Options	Insert 2, 3 or 4-digit Item Code to specify Fitting type	12 - 12"	06 - 6"	06 - 6"	G - Geomet Plated Steel	
5 - 5" High	2 - NEMA Classes 20A, 20B & 20C	09 - 9" Rung Spacing	Insert 2-Digit Bottom Code (See Page 14 -15) to specify optional rungs and bottoms		24 - 24"	09 - 9"	09 - 9"		S - Stainless Steel Type 316
6 - 6" High	3 - NEMA Classes exceeding 20C	12 - 12" Rung Spacing			00 - Square Corners	12 - 12"	18 - 18"		
7 - 7" High	4 - 8" High System A820E	VT - Ventilated/Trough			BLANK - Reducer Fittings	18 - 18"	24 - 24"		
8 - 8" High		SF - Solid Flat Bottom				30 - 30"	30 - 30"		
		SFU - Solid Flat Bottom, Under Rungs				36 - 36"	36 - 36"		

Non-standard lengths and widths are available; consult factory for lead times

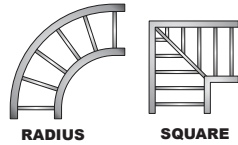


I-Beam Ladder

Horizontal Elbows

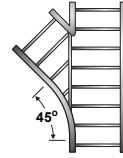
90° Elbow
Item Code

90H



WYE - Left
Item Code

HYL



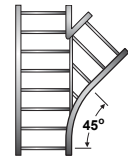
60° Elbow
Item Code

60H



WYE - Right
Item Code

HYR



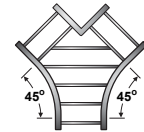
45° Elbow
Item Code

45H



WYE Straight
Item Code

HYS



30° Elbow
Item Code

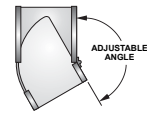
30H



Adjustable Elbow
Item Code

HAE

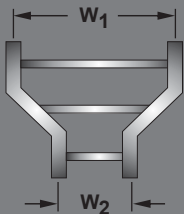
- No Radius
- Max. 35° bend



Reducers

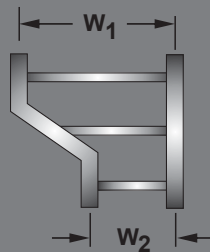
Straight
Item Code

RS



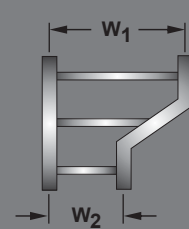
Left - Hand
Item Code

RL



Right - Hand
Item Code

RR

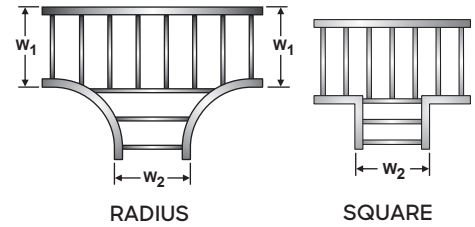


Tees and Crosses

Horizontal Tee

Standard Tee $W1 = W2$
 Reducing Tee $W1 > W2$
 Expanding Tee $W1 < W2$

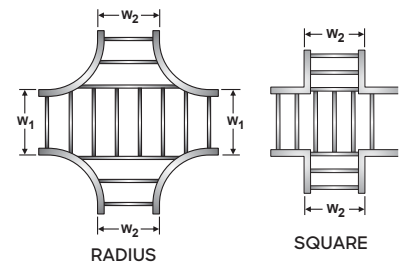
HT
 HTR
 HTE



Horizontal Cross

Standard Cross $W1 = W2$
 Reducing Cross $W1 > W2$

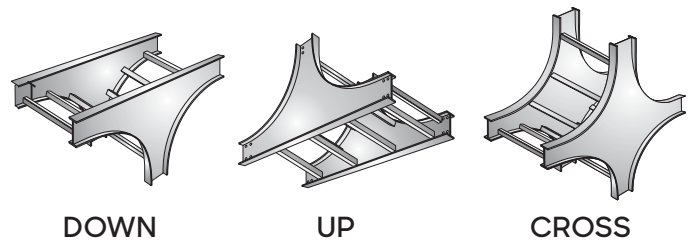
HC
 HCR



Vertical Tee

Vertical Tee Down
 Vertical Tee Up
 Vertical Cross

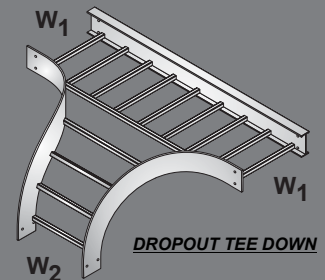
VTD
 VTU
 VC



Dropout Tee with Vertical Riser Tap

Standard Tee $W1 = W2$
 Reducing Tee $W1 > W2$
 Expanding Tee $W1 < W2$

↓ DTD / ↑ DTU
 ↓ DTDR / ↑ DTUR
 ↓ DTDE / ↑ DTUE

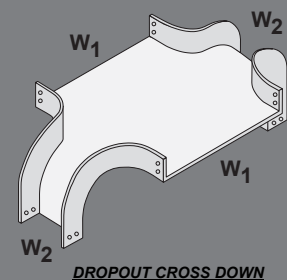


Dropout Cross with Vertical Riser Taps

Standard Cross $W1 = W2$
 Reducing Cross $W1 > W2$
 Expanding Cross $W1 < W2$

↓ DCD / ↑ DCU
 ↓ DCDR / ↑ DCUR
 ↓ DCDE / ↑ DCUE

- Horizontal Cross combined with two vertical riser taps
- Ideal for tight spaces
- Dropout Cross Down (shown) – Taps turn down vertical
- Dropout Cross Up (not shown) – Taps turn up vertical
- Can be customized with special widths and radius



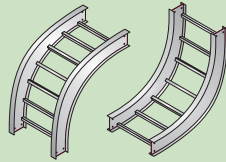
Note: Dropout Tee/Cross Type ↓ = Down / ↑ = Up

I-Beam Ladder

Vertical Elbows

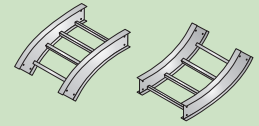
90° Vertical Elbow

Vertical Outside 90VO
Vertical Inside 90VI



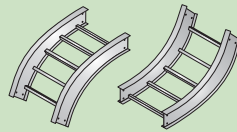
45° Vertical Elbow

Vertical Outside 45VO
Vertical Inside 45VI



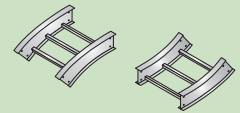
60° Vertical Elbow

Vertical Outside 60VO
Vertical Inside 60VI



30° Vertical Elbow

Vertical Outside 30VO
Vertical Inside 30VI

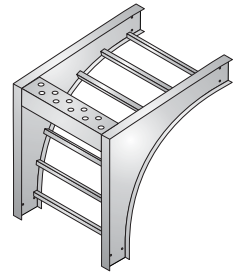


90° Cable Support Elbow (Vertical Outside)

Item Code

CSE

- Equivalent to standard 90° vertical outside elbow with additional bracing
- Square outer corners
- Angle brace on top with holes for 3/8" dia. fasteners
- Attach eye bolts or hooks to support Kellums cable grips and relieve tension in long vertical cable drops
- Also provides alternatives to support elbow from above

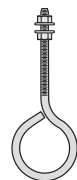


Eye Bolt Kit

Catalog #

F-EB-38-5-S

- 3/8" Dia. x 5 Long Eye Bolt and (2) 3/8" Flanged Hex Nuts
- Stainless Steel
- Use in Cable Support Elbow to attach Kellums cable grips

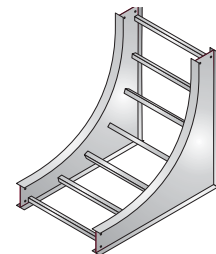


90° Cable Support Elbow (Vertical Inside)

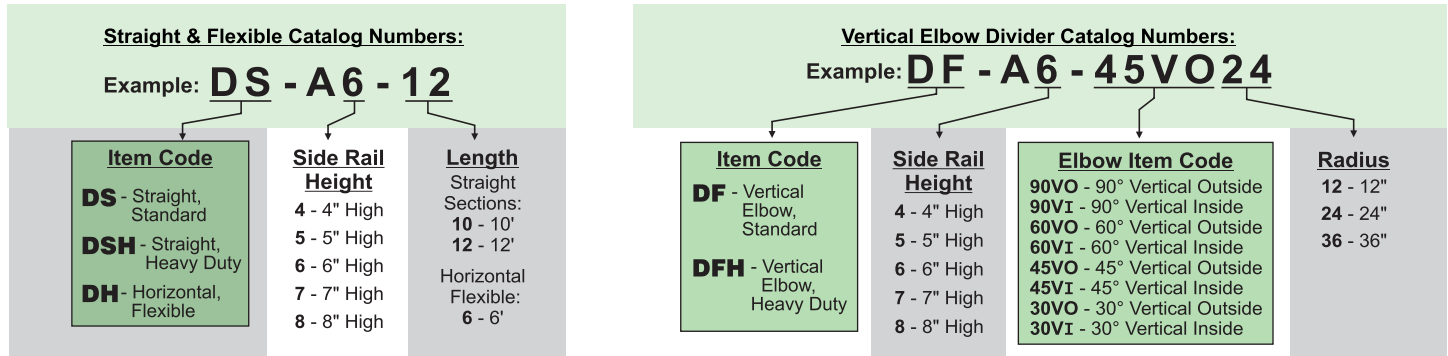
Item Code

BSE

- Equivalent to standard vertical inside elbow with additional bracing
- Square outer corners
- Provides alternatives to support the elbow from below



Dividers

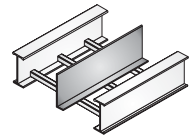


Straight

Item Code

DS

- Supplied with (4) #10 self-drilling, stainless steel screws

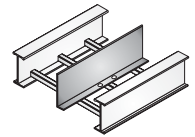


Straight - Heavy Duty

Item Code

DSH

- Includes holes for installation with U-Bolt Divider Clamps (ordered separately)

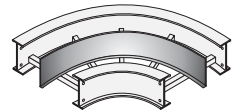


Horizontal Flexible

Item Code

DH

- Supplied with (3) #10 self-drilling, stainless steel screws



Vertical Elbow

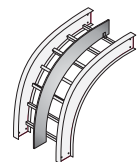
Item Code

DF

Item Code

DFH

- Standard: Supplied with (2) #10 self-drilling, stainless steel screws
- Heavy-Duty: Includes holes for installation with U-Bolt Divider Clamps (ordered separately)



Divider Splice

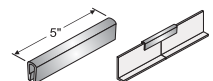
Catalog #

DVS-5 (Length = 5)

Catalog #

DVS-(L)* (L* = Inches)

- Flexible PVC with internal metal clips
- Align and protect divider ends
- Can be cut to custom lengths
- Cope offers 5", 144" and 100' as standard



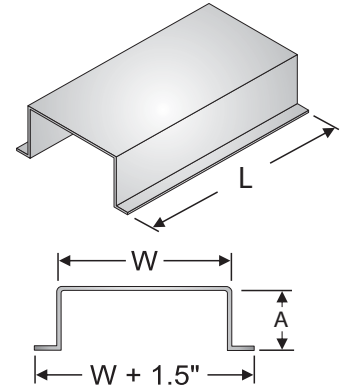
I-Beam Ladder

Dividers

Cable Bridge for Divided Tees and Crosses

Catalog # CB - A (H)*-(W)*-(L)*

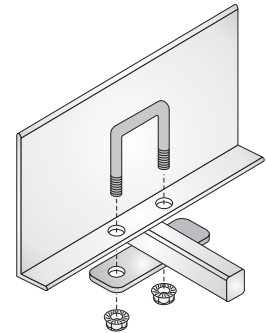
- Provides support for vertical cable separation where cables cross in divided Horizontal Tees and Crosses
- Dimensions can be customized to meet specific project requirements. Includes (6) #10 x 1" long self-drilling, stainless steel screws
- Standard height A is typically ½ of the tray interior load depth
- Standard length (L)* is typically 20"
- (H)* Insert tray side rail height in inches (4, 5, 6, 7, 8)
- (W)* Insert Bridge width in inches (03, 4.5, 06, 09, 12, 15, 18, 24, 30)
- (L)* Insert Bridge length in inches (05, 08, 12, 18, 20, 24, 27, 30, 36)



U-Bolt Divider Clamp Kit

Catalog # DHC-A-S

- Heavy-duty for high winds
- Install on 36"-48" centers (same as Tek screws in standard configuration)
- Includes U-Bolt, alum. plate and (2) ¼" flanged hex nuts
- Bolt and nuts are type 316 Stainless Steel

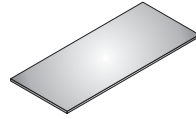


I-Beam Ladder

Covers

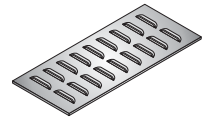
Flat, Non-Flanged, Solid
Cover System

FNS



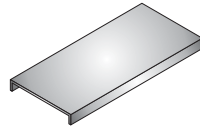
Flat, Non-Flanged, Ventilated
Cover System

FNV



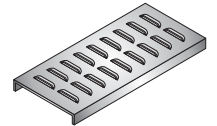
Flat, Flanged, Solid
Cover System

FFS



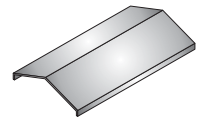
Flat, Flanged, Ventilated
Cover System

FFV



Peaked 20°, Flanged, Solid
Cover System

PFS



Straight Cover Catalog Numbers:

Example: **AC - FFS - SL12 - 24 - 125**

Material	Cover System	Item Code	Length	Width	Thickness
AC Aluminum Cover	FNS FFS FNV FFV PFS	SL Straight Length	Standard: 06 - 6'-0" 12 - 12'-0" Non-standard lengths are available; consult factory for lead times	06 - 6" 09 - 9" 12 - 12" 18 - 18" 24 - 24" 30 - 30" 36 - 36"	040 - 0.040" (Standard) Alternates: 063 - 0.063" 080 - 0.080" 090 - 0.090" 125 - 0.125" 188 - 0.188"

Fitting Cover Catalog Numbers:

Example: **AC - FFS - 90VO12 - 18 - 125 - 6**

Material	Cover System	Item Code	Radius	Width	Thickness	Side Rail Height
AC Aluminum Cover	FNS FFS FNV FFV PFS	Fitting Item Code Pages 18 - 21	00 - Square 12 - 12" 24 - 24" 36 - 36" OR Reducer Width W1	06 - 6" 09 - 9" 12 - 12" 18 - 18" 24 - 24" 30 - 30" 36 - 36" OR Reducer Width W2	040 - 0.040" (Standard) Alternates: 063 - 0.063" 080 - 0.080" 090 - 0.090" 125 - 0.125" 188 - 0.188"	For Outside Vertical Elbows Only; Leave Blank For All Other Fittings

I-Beam Ladder

Cover Connectors

Cover Clamp Catalog Numbers:

Example: **CFS - A6 - 18 - S**

Item Code	Material	Side Rail Height	Width	Hardware Material
Clamp	A	4 - 4" High	06 - 6"	S - Stainless Steel 316 (Standard Hardware Material)
Item	Aluminum	5 - 5" High	09 - 9"	
Code		6 - 6" High	12 - 12"	
		7 - 7" High	18 - 18"	
		8 - 8" High	24 - 24"	
			30 - 30"	
			36 - 36"	

Recommended Quantity of Cover Connectors

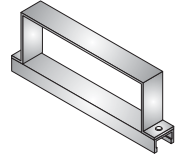
Cover Type	Quantity	
	Standard Clips	Clamps
Straight Section 6' L	4	2
Straight Section 12' L	6	3
Elbows	4	2
Tees	6	3
Crosses	8	4

Vertical Outdoor Cover Clamps

Flat Strap

Cover Clamp

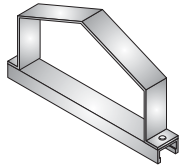
CFS



Peaked Strap

Cover Clamp

CPS



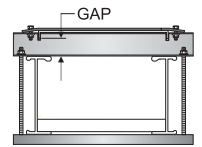
Elevated Cover Clamp**

Cover Clamps.

*CCEF

(+)* Specify Gap = 1", 2", 3", 4"

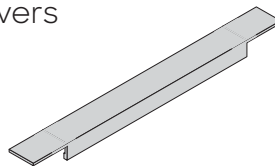
**Peaked Elevated Cover Clamps are available upon request. Please contact the factory at CopeMarketing@atkore.com.



Cover Support Brace

Catalog # CS-A-(W)*

- Reinforces sagging Covers
- Install under covers on 24" to 36" centers
- Aluminum extrusion
- (W)* = Insert Nominal tray width in inches

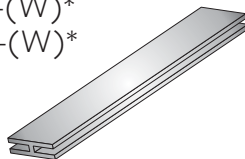


Aluminum Cover Joint Strip

Cover Flat CJF-(W)*

Cover Peaked CJP-(W)*

- (W)* = Insert Nominal tray width in inches

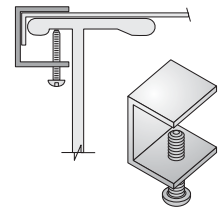


Cover Clips Indoor & Horizontal Use

Standard Cover Clips

CCS-S

- Indoor Use Only
- 18-8 Stainless Steel Clip & Screw



Raised Cover Clip

Fitting Class 1

Fitting Class 2

Fitting Class 3

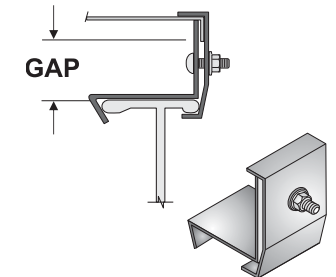
CCR-A(+)* -1-(F)*

CCR-A(+)* -2-(F)*

CCR-A(+)* -3-(F)*

- Indoor Use Only
- Aluminum Clip
- (+) Specify Gap = 1, 2, 3, 4

(F)* = Insert **Z** or **S**



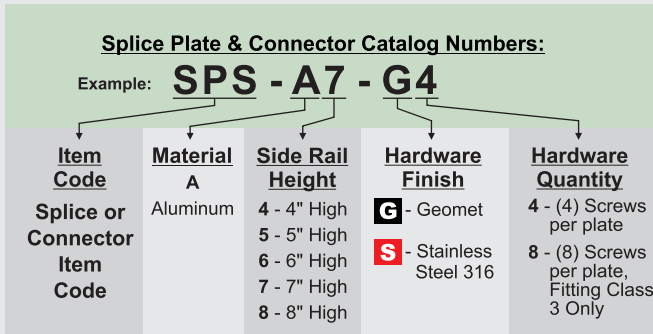
F* = Fastener Materials

G Steel, Geomet Plated

Z Steel, Zinc Plated

S Stainless Steel, Type 316

Splices & Connectors



All **Splice Plates** (except reducing) are supplied in pairs. Geomet-plated steel hardware is supplied with all splices and connectors. Type 316 stainless steel hardware is optional.

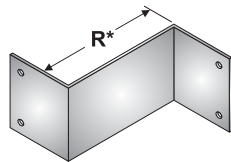
Standard Splice Plates are automatically included with all straight tray sections and fittings. Extras for field cuts or spares should be ordered separately.

Bonding Jumpers are required for use only with expansion connectors and at discontinuities in the tray system. Bonding jumpers are not required for use with vertical or horizontal adjustable connectors.

Offset Reducing

Item Code

SPR-(R)*

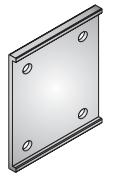


- Supplied each, not in pairs
- (R)* Insert Reduction in inches (R)* = 1.5, 3, 4.5, 6, 7.5, 9, 10.5, 12, 13.5, 15, 18, 21, 24, 27, or 30

Standard

Item Code

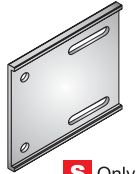
SPS



Expansion

Item Code

SPE

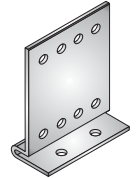


S Only

Mid-Span

Item Code

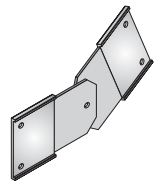
SPM



Vertical Adjustable

Item Code

SPV

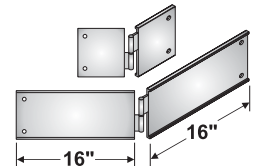


Horizontal Adjustable

Item Code

SPH

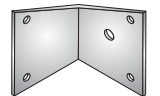
- For odd angle bends up to 30°



Box Connector

Item Code

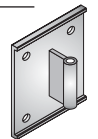
SPB



Horizontal Trays

Item Code

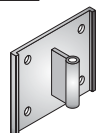
SHH



Vertical Trays

Item Code

SVH



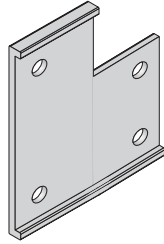
I-Beam Ladder

Splices & Connectors

Step-Down (Reducing Height)

Catalog # SPD-(H1)*(H2)*

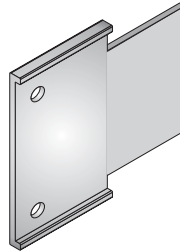
- Transition between different side rail heights
- Step down from nominal side rail Height H1 to H2
(H)* = 4",5",6",7", or 8"



Conversion Plate

Item Code SPC

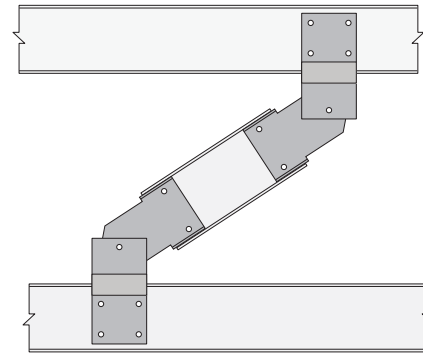
- Holes on one side connect to Cope components
- No holes on opposite side for field modifications



Branch Pivot Connectors

Item Code SPP

- Transition between trays
- Adjustable to any angle
- Supplied in pairs with fasteners
- One pair required for each tray-to-tray connection
- Two pairs required to make transition shown in illustration

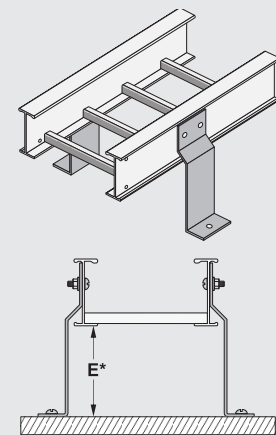


Side View

Floor Support Brackets

Catalog # SPFS-A(H)*-(E)*-(F)*-2

- Supports tray directly above floor
- Elevation (E)* as required, 36" Max.
- Tray connection hardware is included
- Floor connection hardware not included
- For applications with multiple tiers of trays stacked vertically, these brackets can be designed to stack on top of each other and share the same 9/16" dia. hole for the floor connection hardware
- Heavy-Duty aluminum material



(H)* Insert nominal tray side rail height

(E)* Insert required tray bottom elevation

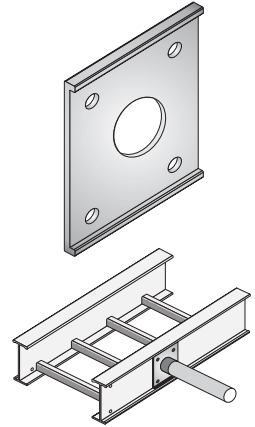
(F)* Insert hardware material **G** or **S**

Splices & Connectors

Conduit Connector Plate for 6 High, NEMA 20C Tray Systems

Catalog # CCP-A6-(D)*-(F)* 4

- Reinforces the tray to permit field-drilled holes in the side rails for conduit connector bushings
- Install up to 6 places anywhere in each side rail of a 20' long tray section and still maintain NEMA 20C load rating
- Load tests per NEMA-VE1 witnessed and certified accurate by UL
- The size of hole required for the conduit bushing shall be specified by customer (2.5" maximum diameter). This is a modified SPS splice plate connector that attaches with standard connector hardware



(D)* Insert required bushing hole diameter

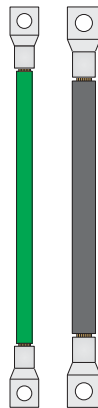
(F)* Insert hardware material **G** or **S**

Bonding & Grounding

Bonding Jumpers

- THHN Copper, Green Insulation, 16 Long
- 250 MCM is Black Welding Cable
- One-hole Lugs sized for 3/8" fasteners
- Fasteners ordered separately
- Consult factory for other sizes and lengths

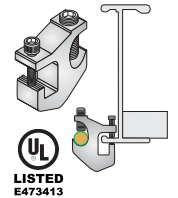
Catalog #	AMP NEC 250.122	Cable Size
GBJ-C-600	600	1
GBJ-C-800	800	1/0
GBJ-C-1000	1000	2/0
GBJ-C-1200	1200	3/0
GBJ-C-1600	1600	4/0
GBJ-C-2000	2000	250



Ground Wire Clamp

Catalog # GWC-A1-Z

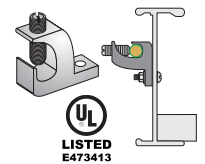
- UL Listed for bonding
- No field-drilling req'd.
- #6 thru 250 MCM wire
- Aluminum clamp
- Zinc plated screws



Ground Wire Lay-In Lug

Catalog # GWL-A-Z

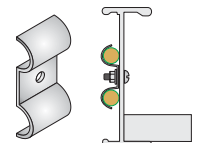
- UL Listed for bonding
- #6 thru 250 MCM wire
- Aluminum clamp
- Field-drilling is required
- Can be factory-welded to side rails as needed
- UL Listed as welded assembly when welded



Ground Wire Support Clamp

- For support only, does not bond
- Clamp is 316 stainless steel
- 1/4" Screw & flanged nut included
- Insert fastener finish (F)* = **Z** or **S**

Catalog #	Cable Size
GWS-S-1-(F)*	#1 thru 2/0
GWS-S-1-(F)*	3/0 thru 250 MCM
GWS-S-1-(F)*	300 thru 500 MCM



I-Beam Ladder

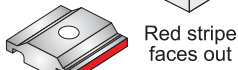
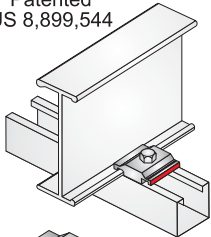
Hold Down Clamps

Hold Down Clamp & Expansion Guide (Series 2, 3 & 4 Trays Only)

Catalog #

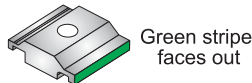
HDH-A

Patented
US 8,899,544



Hold Down Clamp

Red stripe
faces out



Expansion Guide

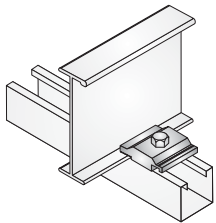
Green stripe
faces out

- Locks on outside flange of tray side rails, preventing movement in all directions
- Functions as Hold Down Clamp and Expansion Guide
- Colored stripes indicate use
- For use only with heavy-duty trays - Series 2, 3 and 4
- Hole sized for $\frac{3}{8}$ " fasteners, ordered separately
- Hole sized for $\frac{1}{2}$ " fasteners is optional, consult factory
- Extruded aluminum

Hold Down Clamp & Expansion Guide (Series 1 Trays Only)

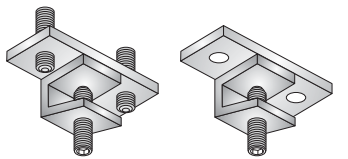
Catalog #

HDL-A



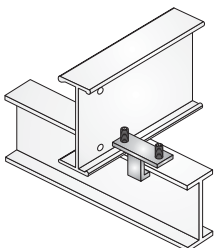
- Hole sized for $\frac{3}{8}$ " fasteners
- Hole sized for $\frac{1}{4}$ " fasteners is optional, consult factory
- Extruded Aluminum

Hold Down Clamp & Expansion Guide, I-Beam



Hold Down **Expansion Guide**

- No drilling of I-Beam support
- Cast Iron material per ASTM A220
- Hot-dip galv. after fab. per ASTM A-123
- $\frac{1}{2}$ " Dia. fasteners included
(F)* Insert **G** or **S**



Catalog #	Type
HHB-H-(F)*	Hold Down Clamp
HEB-H-(F)*	Expansion Guide

Hold Down Clamps

Hold Down Brackets

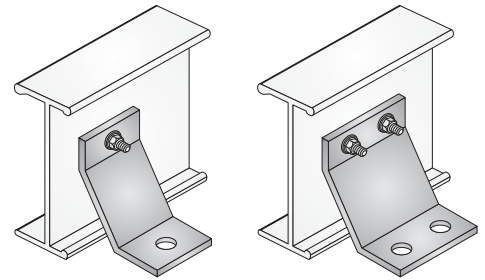
2 Holes

HBT-A-(F)*

4 Holes

HBF-A-(F)*

- Aluminum
- 3/8" tray attachment hardware included
- 1/2" support attachment hardware not included

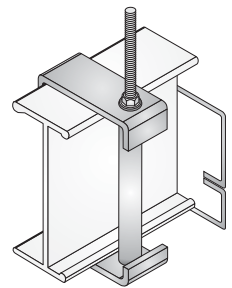


Hanger Rod Clamp

Catalog #

HRC-Z(H)*-(C)*

- Zinc plated steel
- Use with 1/2" threaded rod, order 1/2" threaded rod and hex nuts separately
- (H)* Insert tray height in inches
- (C)* Insert Fitting Class = 1, 2 or 3



Conduit Attachment Bracket & Clamp

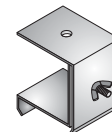
Bracket

CAB-(C)*-(F)*

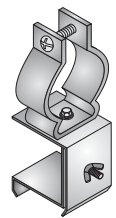
Bracket Clamp

CAC-(D+)*-(C)*-(F)*

- Aluminum Bracket
- Specify conduit type (D)* = R for Rigid, E for EMT
- Specify conduit size in inches (+)* = .5, .75, 1, 1.25, 1.5, 2, 2.5, 3, or 4
- Specify Tray Fitting Class (C)* = 1, 2, 3 or 4
- (F)* Insert **G** or **S** for clamp & fastener material



Bracket



Bracket + Clamp



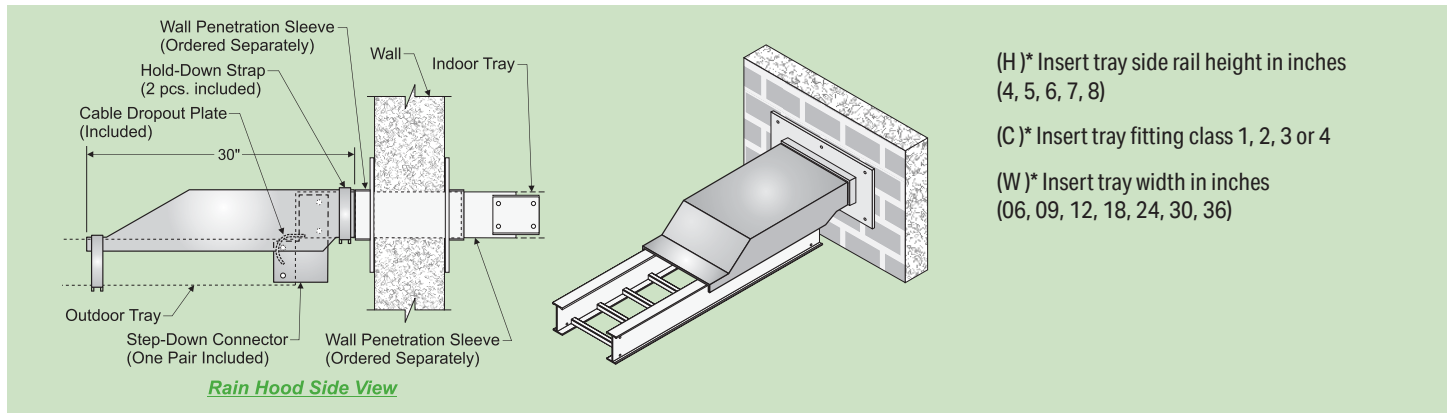
I-Beam Ladder

Accessories

Rain Hood for Wall Penetration Sleeve

Catalog # RHP-A(H)*-(C)*-(W)* S

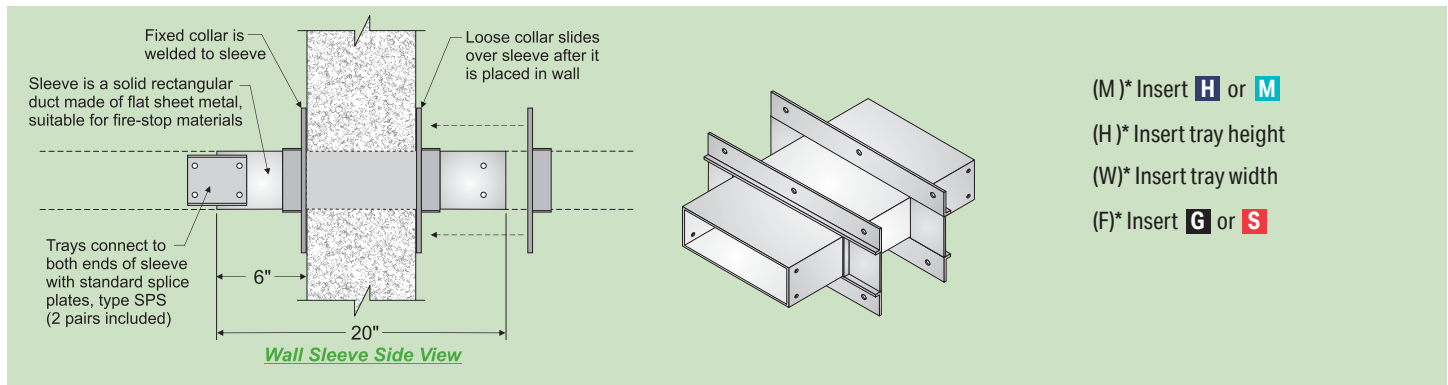
- Cover attaches to Wall Penetration Sleeve
- Top of outdoor tray attaches to bottom of sleeve to create downhill Drip Loop in cables and prevent water from seeping into building
- Aluminum materials
- Fasteners are stainless steel type 316
- Rain Hood attaches independently of tray and sleeve assembly



Wall Penetration Sleeve

Catalog # WPS-(M)*(H)*-(W)*-(F)*

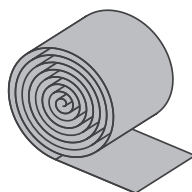
- Steel: Mill-Galv. or Hot-Dip Galvanized
- 2 pairs of splice plates and 3/8" tray attachment hardware included



I-Beam Neoprene Roll

Catalog # NR-18-2

- 1/8" x 2"
- 25' roll
- Good isolator
- Other sizes available



Accessories

Replacement Rungs

Ladder

Strut Profile

Marine Slotted

RRL-A-(W)*-(F)*

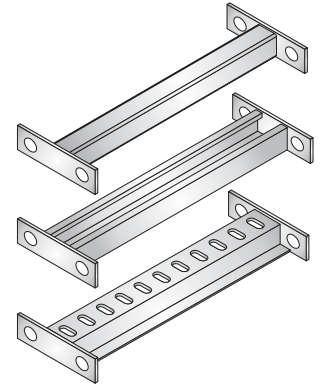
RRS-A-(W)*-(F)*

RRM-A-(W)*-(F)*

- Replace damaged rungs in field
- Add to support heavy point loads
- Installation hardware included

(W)* Insert tray width

(F)* Insert **G** or **S**



Nylon Pads

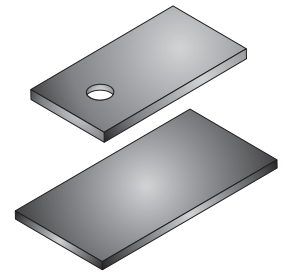
3" x 6" Solid

3" x 2" with 1/2" Hole:

- 1/8" Thick Black Nylon
- UV Rated for Outdoor Use

NP-36

NP-32-12



Blind End Plate & Box Connector, Frame-Type

Blind End (Ladder)

Blind End (Solid-Bottom):

Box Conn:

BE-A(H)*-(W)*-(F)*

BE-A(H)*-(W)*-(F)*-SB

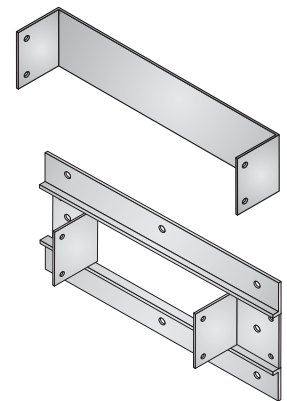
BC-A(H)*-(W)*-(F)*

- Aluminum
- 3/8" tray attachment hardware included

(H)* Insert tray height

(W)* Insert tray width

(F)* Insert **G** or **S**



M* = Part Materials

H Steel, Hot-Dip Galv. After Fab. (ASTM A123)

M Steel, Mill-Galvanized (ASTM A653)

S Stainless Steel, Type 316

F* = Fastener Materials

G Steel, Geomet Plated

Z Steel, Zinc Plated

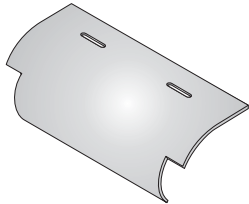
S Stainless Steel, Type 316

I-Beam Ladder

Accessories

Ladder Cable Dropout

Catalog #



LD-A-(C)*-(W)*-(F)*

- 3" radius
- Aluminum
- ¼" fasteners included

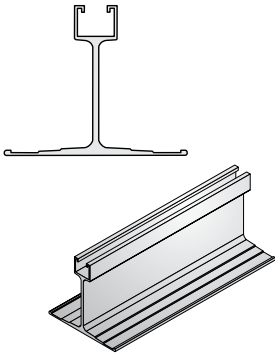
(W)* Insert tray width

(F)* Insert **Z** or **S**

(C)* Class 1, 2, 3 or 4

Roof Block Support

Catalog #



RB-A-(W)*

- Solid aluminum
- 6" high support
- 7" wide base
- Heavy-duty
- Strut profile on top
- Cut to any length
- Neoprene and adhesive bases available

(W)* Insert tray width



FEATURES

SWAGE

I-BEAM

TROF

EAGLE BASKET

CHANNEL

GLAS

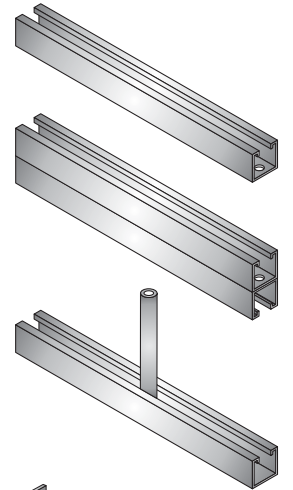
AICKINSTRUT

DATA

Hanger Channels

Hanger Channel Single Strut	HCS-(M)-(W)*
Hanger Channel Double Strut	HCD-(M)-(W)*
Hanger Channel Center Hung	HCC-H-(W)*

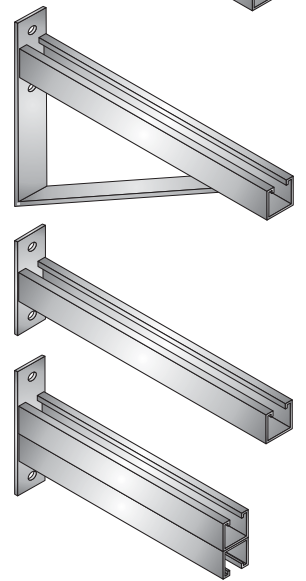
- All hanger channels made from 1-5/8" deep x 12 Ga. steel struts
- (M)* Insert material: **M** = Mill-Galvanized; **H** = Hot-Dip Galvanized
- (W)* Insert channel width in inches:
 - Single & double use nominal tray width + 12".
 - For center-hung channel use tray width + 6"












Wall Brackets

Wall Bracket, Heavy Duty	WBH-H-(W)*
Wall Bracket, Single Channel	WBS-H-(W)*
Wall Bracket, Double Channel	WBD-H-(W)*

- Material: Steel, Hot-Dip Galvanized After Fabrication Per ASTM A-123
- Wall brackets, heavy duty made from 1" deep x 12 Ga. steel strut
- Wall brackets, single & double made from 1 5/8" deep x 12 Ga. steel struts
- (W)* Insert bracket width in inches:
 - Use nominal tray width + 6"



Support Hardware Kits							
Support Type	Duty	Light Duty Hold Down Clip	Heavy Duty Hold Down Clip	Hex Bolt 1 1/2 Long	Spring Nut	1 1/2 Square Washer	Flanged Hex Nut
	Light	2		2 (1/4)	2 (1/4)	4 (3/8 or 1/2)	4 (3/8 or 1/2)
	Heavy		2	2 (3/8)	2 (3/8)	4 (3/8 or 1/2)	4 (3/8 or 1/2)
	Light	2		2 (1/4)	2 (1/4)	1 (3/8 or 1/2)	2 (3/8 or 1/2)
	Heavy		2	2 (3/8)	2 (3/8)	1 (3/8 or 1/2)	2 (3/8 or 1/2)
	Light	2		2 (1/4)	2 (1/4)		
	Heavy		2	2 (3/8)	2 (3/8)		








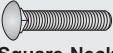
38 = 3/8, 12 = 1/2 Hardware for use with 3/8 or 1/2 threaded rod


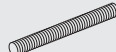






Chart above shows quantities of each item included in kits, supplied in plastic bags.



I-Beam Ladder

Fasteners & Hardware

Type	Catalog #	Size	Use
 Ribbed Neck Screw	F-RNS-38-34-(G or S)	3/8" x 3/4"	A, D, F, L
 Flanged Hex Nut	F-FHN-14-(Z or S) F-FHN-38-(G or S) F-FHN-12-(Z or S)	1/4" 3/8" 1/2"	B,E,G,J,M,N A,C,D,F,H,L C,H
 Standard Hex Nut	F-SHN-38-(Z or S) F-SHN-12-(Z or S)	3/8" 1/2"	K
 Locking Hex Nut	F-LHN-38- S	3/8"	D
 Flat Round Washer	F-FRW-14-(Z or S) F-FRW-38- S F-FRW-12-(Z or S)	1/4" 3/8" 1/2"	E D
 Hex Bolt	F-HHB-14-15-(Z or S) F-HHB-38-15-(Z or S) F-HHB-12-15-(Z or S)	1/4" x 1 1/2" 3/8" x 1 1/2" 1/2" x 1 1/2"	G H H, L
 Slotted, Round-Head Screw	F-SRS-14-15-(Z or S) F-PRS-38-34- S F-SRS-38-15-(Z or S)	1/4" x 1 1/2" 3/8" x 3/4" 3/8" x 1 1/2"	E D K
 Square-Neck Carriage Bolt	F-SNC-14-34-(Z or S) F-SNC-14-5- Z F-SNC-14-6- Z F-SNC-14-7- Z F-SNC-14-8- Z	1/4" x 3/4" 1/4" x 5" 1/4" x 6" 1/4" x 7" 1/4" x 8"	B,M N-4High N-5High N-6High N-7High

Type	Catalog #	Size	Use
 Threaded Rod	F-THR-14-72-(Z or S) F-THR-38-144-(Z or S) F-THR-12-144-(Z or S)	1/4" x 6' 3/8" x 12' 1/2" x 12'	C
 Threaded Stud	F-THS-14-6-(Z or S) F-THS-14-7-(Z or S) F-THS-14-8-(Z or S) F-THS-14-9-(Z or S)	1/4" x 6 1/4" x 7 1/4" x 8 1/4" x 9	N-4High N-5High N-6High N-7High
 Rod Coupler Nut	F-RCN-14-(Z or S) F-RCN-38-(Z or S) F-RCN-12-(Z or S)	1/4" 3/8" 1/2"	C
 Spring Nut	F-CNS-14-(Z or S) F-CNS-38-(Z or S) F-CNS-12-(Z or S)	1/4" 3/8" 1/2"	C,G C,H C,H
 Channel Nut, Without Spring	F-CNW-14-(Z or S) F-CNW-38-(Z or S) F-CNW-12-(Z or S)	1/4" 3/8" 1/2"	G H H
 1 1/2" Square Channel Washer	F-SCW-14-(Z or S) F-SCW-38-(Z or S) F-SCW-12-(Z or S)	1/4" Hole 3/8" Hole 1/2" Hole	C C C
 Beam Clamp	F-HBC-14-(Z or S) F-HBC-38-(Z or S) F-HBC-12-(Z or S)	1/4" Rod 3/8" Rod 1/2" Rod	C-650 lbs C-1100 lbs C-1600 lbs
 Self-Drilling Screw	F-SDS-10-1- S	#10 x 1"	P

F* = Fasteners Materials

- G** Steel, Geomet Plated
- Z** Steel, Zinc Plated
- S** Stainless Steel, Type 316

Fastener Uses

- (A) Splice plates & tray connectors
- (B) Flat & peaked strap cover clamps
- (C) Trapeze hangers & supports
- (D) Expansion connectors
- (E) Cable dropouts
- (F) Blind ends
- (G) Hold Down Clamp - HDL
- (H) Hold Down Clamp - HDH
- (J) Ground wire support clamps
- (K) Bonding Jumpers
- (L) Hold down brackets
- (M) Conduit clamp brackets
- (N) Channel & elevated cover clamps
- (P) Dividers



Corrugated Bottom Cable TROF System for Power, Control, Instrumentation Cable & Pneumatic Tubing

Contents

General & Technical Information

Pictorial Index 85
 Selection Chart: Cope Trof - Aluminum 86
 Selection Chart: Cope Trof - Steel..... 88
 Overview 90
 Part Number Structure..... 92
 CSA Part Number Structure..... 94
 CSA Selection Chart: Aluminum/Steel..... 96
 Straight Length 97

Cope Trof Fittings

Horizontal Elbows
 90° 98
 60° 98
 45° 99
 30° 99
 Horizontal Tee & Cross..... 100
 Horizontal Tapped Tee & Tapped Cross..... 101
 Straight Reducers..... 105
 Left and Right Hand Reducers 106
 Adjustable Elbow 107
 45° Y Branch..... 107
 Vertical Elbows (Inside and Outside)
 90° 108
 60° 108
 45° 109
 30° 109
 90° Vertical Cable Support Elbow 110
 Vertical Tee..... 110

Cope Trof Accessories

Connector Plates 111
 Hardware 112
 Covers & Cover Accessories 113
 Accessories (Drop Out, Blind End, Clamps, Bonding Jumper)..... 116
 Barrier Strips & Accessories..... 118
 Hold-Down Clamp & Expansion Guide, Seismic Hold-Down, Grommet 119
 Support Brackets & Tray Hangers..... 120

Specification Information

Electrical Grounding Chart..... 123
 Typical Specification..... 124

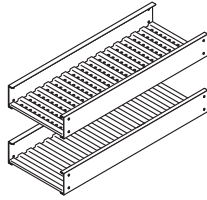


Pictorial Index

Pictorial Index

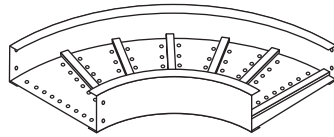
Straight Length

Page 97



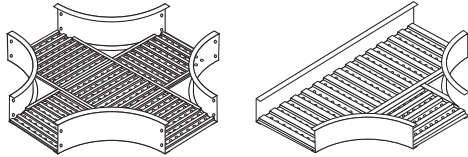
Horizontal Elbows

Pages 98



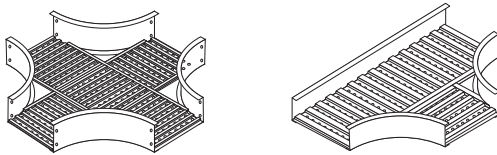
Horizontal Tee & Cross

Pages 100



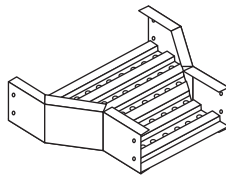
Tapped Tee & Cross

Page 101



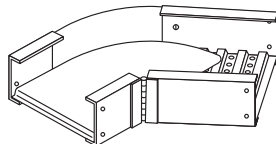
Reducers

Page 105



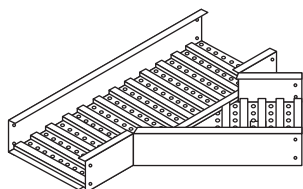
Adjustable Elbows

Page 107



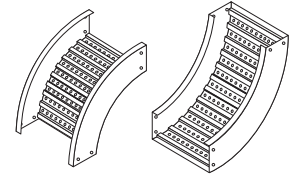
45° Y Branch

Page 107



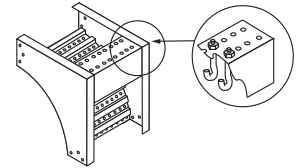
Vertical Elbows

Pages 108



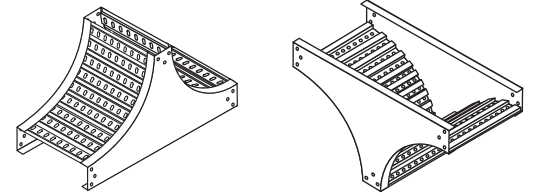
90° Vertical Cable Support Elbow

Page 110



Vertical Tee

Page 110



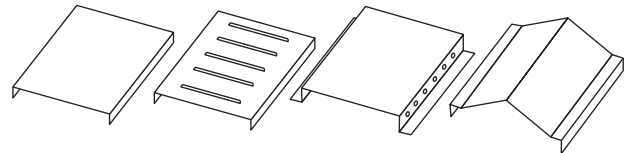
Connector Plates

Pages 111



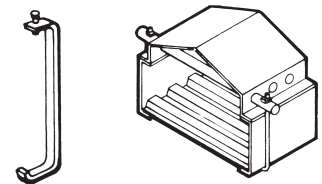
Covers

Page 113



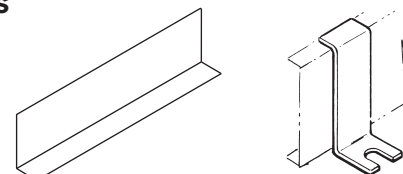
Cover Accessories

Page 114



Accessories

Page 116



Aluminum Tray

NEMA Class, Physical And Structural Properties

NEMA Standard VE-1 Load/Span Class	NEMA Load/Span	Cope System Number	Cope Systems Certified by CSA	Nominal Load Depth		Side Rail Height		Flange Width	Section Modulus of 2 Rails S _x	Moment of Inertia for 2 Rails I _x	Min X-Sect. Area of 2 Rails per NEC 392.7
8A-12A	50 lb./ft. 12' span	5234	-	3"	76mm	3 ½"	89mm	1 3/16"	0.800 in ³	1.400 in ⁴	.60 in ²
		1B44	1B44	4"	102mm	4 ¼"	108mm	1 3/16"	0.898 in ³	1.822 in ⁴	.60 in ²
		1B54	1B54	5"	127mm	5 ¼"	133mm	1 3/16"	1.142 in ³	2.872 in ⁴	.60 in ²
		3B64	-	6"	152mm	6 ¼"	159mm	1 3/16"	1.614 in ³	4.720 in ⁴	1.00 in ²
12B	75 lb./ft. 12' span	3B44	-	4"	102mm	4 ¼"	108mm	1 3/16"	1.148 in ³	2.316 in ⁴	.60 in ²
		1B54	1B54	5"	127mm	5 ¼"	133mm	1 3/16"	1.142 in ³	2.872 in ⁴	.60 in ²
		3B64	-	6"	152mm	6 ¼"	159mm	1 3/16"	1.614 in ³	4.720 in ⁴	.60 in ²
12C	100 lb./ft. 12' span	5B44	-	4"	102mm	4 ¾"	108mm	1 3/16"	1.646 in ³	3.058 in ⁴	1.00 in ²
		3B54	-	5"	127mm	5 ¼"	133mm	1 3/16"	1.522 in ³	3.734 in ⁴	1.00 in ²
		5B64	-	6"	152mm	6 ¼"	159mm	1 3/16"	1.944 in ³	5.866 in ⁴	1.00 in ²
16A	50 lb./ft. 16' span	5B44	-	4"	102mm	4 ¼"	108mm	1 3/16"	1.646 in ³	3.058 in ⁴	1.00 in ²
		7454	7454	5"	127mm	5 ¼"	133mm	1 ¼"	2.396 in ³	6.292 in ⁴	1.50 in ²
		1D64	1D64	6"	152mm	6 ¼"	159mm	1 ¼"	2.378 in ³	7.202 in ⁴	1.00 in ²
16B	75 lb./ft. 16' span	3D44	3D44	4"	102mm	4 ¼"	108mm	1 ¼"	2.242 in ³	4.406 in ⁴	1.00 in ²
		7454	7454	5"	127mm	5 ¼"	133mm	1 ¼"	2.396 in ³	6.292 in ⁴	1.50 in ²
		1D64	1D64	6"	152mm	6 ¼"	159mm	1 ¼"	2.378 in ³	7.202 in ⁴	1.00 in ²
16C	100 lb./ft. 16' span	5D44	5D44	4"	102mm	4 ¼"	108mm	1 ¼"	2.782 in ³	5.738 in ⁴	1.50 in ²
		3D54	3D54	5"	127mm	5 ¼"	133mm	1 ¼"	3.434 in ³	8.746 in ⁴	2.00 in ²
		7D64	-	6"	152mm	6 ¼"	159mm	1 ¼"	4.186 in ³	12.024 in ⁴	2.00 in ²
20A	50 lb./ft. 20' span	3D44	-	4"	102mm	4 ¼"	108mm	1 ¼"	2.242 in ³	4.406 in ⁴	1.00 in ²
		7454	7454	5"	127mm	5 ¼"	133mm	1 ¼"	2.396 in ³	6.292 in ⁴	1.50 in ²
		1D64	1D64	6"	152mm	6 ¼"	159mm	1 ¼"	2.378 in ³	7.202 in ⁴	1.00 in ²
20B	75 lb./ft. 20' span	3D54	3D54	5"	127mm	5 ¼"	133mm	1 ¼"	3.434 in ³	8.746 in ⁴	2.00 in ²
		7D64	7D64	6"	152mm	6 ¼"	159mm	1 ¼"	4.186 in ³	12.024 in ⁴	2.00 in ²
20C	100 lb./ft. 20' span	7D44	7D44	4"	102mm	4 ¼"	108mm	1 ¼"	3.512 in ³	6.956 in ⁴	2.00 in ²
		5D54	-	5"	127mm	5 ¼"	133mm	1 ¼"	3.910 in ³	10.020 in ⁴	2.00 in ²
		7D64	7D64	6"	152mm	6 ¼"	159mm	1 ¼"	4.186 in ³	12.024 in ⁴	2.00 in ²
EXTRA HEAVY DUTY - VERY LONG SPAN TRAYS - SOLID OR VENTILATED BOTTOMS											
		9D64	-	6"	152mm	6 ¼"	159mm	1 ¼"	5.130 in ³	15.700 in ⁴	2.00 in ²
		7G64	-	6"	152mm	6 ¼"	159mm	2"	5.804 in ³	17.456 in ⁴	2.00 in ²



Aluminum Tray

Load And Deflection Data For Aluminum Trof Working (Allowable) Load Capacity, Evenly Distributed - Tested per NEMA Standard VE-1 Span (Ft.) - Simple Beam - SAFETY FACTOR: 1.5

Cope Sys. No.	6 Ft. Span			8 Ft. Span			10 Ft. Span			12 Ft. Span			16 Ft. Span			20 Ft. Span			24 Ft. Span			25 Ft. Span			
	w	d	k	w	d	k	w	d	k	w	d	k	w	d	k	w	d	k	w	d	k	w	d	k	
5234	207	.43	.002	117	.77	.007	75	1.20	.016	52	1.73	.033													
1B44	222	.35	.002	125	.63	.005	80	.99	.012	55	1.42	.026													
1B54	324	.33	.001	182	.59	.003	117	.87	.007	77	1.26	.016													
3B64	359	.22	†	191	.37	.002	115	.55	.005	75	.74	.010													
3B44	354	.45	.001	191	.76	.004	117	1.14	.010	78	1.57	.020													
1B54	324	.33	.001	182	.59	.003	117	.87	.007	77	1.26	.016													
3B64	359	.22	†	191	.37	.002	115	.55	.005	75	.74	.010													
5B44	362	.32	†	251	.69	.003	161	1.08	.007	112	1.55	.014													
3B54	394	.31	†	222	.55	.002	142	.86	.006	100	1.24	.012													
5B64	480	.24	†	257	.40	.002	156	.60	.04	102	.81	.008													
5B44				251	.69	.003	161	1.08	.007	112	1.55	.014	51	2.26	.044	25	2.75	.110							
7454				349	.51	.001	223	.80	.004	155	1.15	.007	79	1.85	.023	51	2.89	.057							
1D64				380	.49	.001	222	.69	.003	154	1.00	.006	78	1.61	.021	50	2.51	.050							
3D44				342	.72	.002	219	1.12	.005	152	1.61	.011	82	2.74	.033	52	4.27	.082							
7454				349	.51	.001	223	.80	.004	155	1.15	.007	79	1.85	.023	51	2.89	.057							
1D64				380	.49	.001	222	.69	.003	154	1.00	.006	78	1.61	.021	50	2.51	.050							
5D44				444	.71	.002	284	1.10	.004	188	1.53	.008	106	2.73	.026	65	4.07	.063							
3D54				525	.55	.001	336	.86	.003	233	1.24	.005	119	2.01	.017	76	3.14	.041							
7D64							404	.76	.002	281	1.09	.004	158	1.94	.012	101	3.02	.030							
3D44										152	1.61	.011	82	2.74	.033	52	4.27	.082							
7454										155	1.15	.007	79	1.85	.023	51	2.89	.057							
1D64										154	1.00	.006	78	1.61	.021	50	2.51	.050							
3D54										233	1.24	.005	119	2.01	.017	76	3.14	.041							
7D64										281	1.09	.004	158	1.94	.012	101	3.02	.030							
7D44										277	2.03	.007	156	3.61	.023	100	5.64	.056							
5D54										290	1.35	.005	156	2.30	.015	100	3.59	.036							
7D64										281	1.09	.004	158	1.94	.012	101	3.02	.030							
EXTRA HEAVY DUTY - VERY LONG SPAN TRAYS - SOLID OR VENTILATED BOTTOMS																									
9D64										412	1.22	.003	214	2.00	.009	131	3.01	.023	68	3.23	.048				
7G64										451	1.20	.003	253	2.14	.008	162	3.35	.020	112	4.79	.043	104	5.24	.050	

Note: To convert 1.5 safety factor to 2.0 multiply w, d, k by .75
w = Pounds per linear foot
Metric: for kg/m multiply w by 1.48
d = Deflection (in.)
k = Deflection (in.) for each pound of load
† = Denotes k is less than .001 inch

Steel Tray

NEMA Class, Physical and Structural Properties

NEMA Standard VE-1 Load/Span Class	NEMA Load/Span	Mill-Galv. System No.	HDGAF System No.	Type 304 SS System No.	Cope HDGAF Systems Certified by CSA	Nominal Load Depth	Side Rail Height	Flange Width	Section Modulus of 2 Rails SX	Moment of Inertia for 2 Rails LX	Minimum X-Sect. Area of 2 Rails per NEC 392.7
8A - 12A	50 lb./ft. 12' span	8232	6233	823U	-	3 (76mm)	3 ½" (89mm)	1 ¾"	0.444 in ³	1.378 in ⁴	.40 in ²
		8242	6243	824U	8242 /3	4 (102mm)	4 ¼" (108mm)	1 ¾"	0.592 in ³	1.258 in ⁴	.40 in ²
		8252	6253	825U	-	5 (127mm)	5 ¼" (133mm)	1 ¾"	0.816 in ³	2.142 in ⁴	.40 in ²
		8262	6263	826U	8262 /3	6" (152mm)	6 ¼" (159mm)	1 ¾"	1.072 in ³	3.352 in ⁴	.70 in ²
12B	75 lb./ft. 12' span	4232	4233	423U	-	3" (76mm)	3 ½" (89mm)	1 ¾"	0.674 in ³	1.180 in ⁴	.70 in ²
		8B42	6B43	8B4U	-	4" (102mm)	4 ¼" (108mm)	1 ¾"	0.678 in ³	1.370 in ⁴	.40 in ²
		8252	6253	825U	-	5" (127mm)	5 ¼" (133mm)	1 ¾"	0.816 in ³	2.142 in ⁴	.40 in ²
		8262	6263	826U	8262 /3	6" (152mm)	6 ¼" (159mm)	1 ¾"	1.072 in ³	3.352 in ⁴	.70 in ²
12C	100 lb./ft. 12' span	6B42	6B43	6B4U	-	4" (102mm)	4 ¼" (108mm)	1 ¾"	0.834 in ³	1.690 in ⁴	.70 in ²
		6B52	6B53	6B5U	-	5" (127mm)	5 ¼" (133mm)	1 ¾"	1.140 in ³	2.872 in ⁴	.70 in ²
		6262	6263	626U	-	6" (152mm)	6 ¼" (159mm)	1 ¾"	1.330 in ³	4.158 in ⁴	.70 in ²
16A	50 lb./ft. 16' span	8D42	6D43	8D4U	-	4" (102mm)	4 ¼" (108mm)	1 ¼"	0.852 in ³	1.736 in ⁴	.40 in ²
		6452	6453	645U	6452 /3	5" (127mm)	5 ¼" (133mm)	1 ¼"	1.280 in ³	3.360 in ⁴	.70 in ²
		6462	6463	646U	6462 /3	6" (152mm)	6 ¼" (159mm)	1 ¼"	1.652 in ³	5.160 in ⁴	.70 in ²
16B	75 lb./ft. 16' span	6D42	6D43	6D4U	-	4" (102mm)	4 ¼" (108mm)	1 ¼"	1.056 in ³	2.152 in ⁴	.70 in ²
		6452	6453	645U	6452 /3	5" (127mm)	5 ¼" (133mm)	1 ¼"	1.280 in ³	3.360 in ⁴	.70 in ²
		6462	6463	646U	6462 /3	6" (152mm)	6 ¼" (159mm)	1 ¼"	1.652 in ³	5.160 in ⁴	.70 in ²
16C	100 lb./ft. 16' span	4D42	4D43	4D4U	-	4" (102mm)	4 ¼" (108mm)	1 ¼"	1.298 in ³	2.652 in ⁴	1.00 in ²
		6452	6453	645U	6452 /3	5" (127mm)	5 ¼" (133mm)	1 ¼"	1.280 in ³	3.360 in ⁴	.70 in ²
		6462	6463	646U	6462 /3	6" (152mm)	6 ¼" (159mm)	1 ¼"	1.652 in ³	5.160 in ⁴	.70 in ²
20A	50 lb./ft. 20' span	6D42	6D43	6D4U	-	4" (102mm)	4 ¼" (108mm)	1 ¼"	1.056 in ³	2.152 in ⁴	.70 in ²
		6452	6453	645U	6452/3	5" (127mm)	5 ¼" (133mm)	1 ¼"	1.280 in ³	3.360 in ⁴	.70 in ²
		6462	6463	646U	6462/3	6" (152mm)	6 ¼" (159mm)	1 ¼"	1.652 in ³	5.160 in ⁴	1.00 in ²
20B	75 lb./ft. 20' span	2D42	2D43	2D4U	-	4" (102mm)	4 ¼" (108mm)	1 ¼"	1.758 in ³	3.604 in ⁴	1.00 in ²
		4D52	4D53	4D5U	4D52 /3	5" (127mm)	5 ¼" (133mm)	1 ¼"	1.744 in ³	4.418 in ⁴	1.00 in ²
		6D62	6D63	6D6U	-	6" (152mm)	6 ¼" (159mm)	1 ¼"	1.814 in ³	5.486 in ⁴	1.00 in ²
20C	100 lb./ft. 20' span	2D52	2D53	2D5U	-	5" (127mm)	5 ¼" (133mm)	1 ¼"	2.370 in ³	6.026 in ⁴	1.50 in ²
		4D62	4D63	4D6U	4D62 /3	6" (152mm)	6 ¼" (159mm)	1 ¼"	2.240 in ³	6.778 in ⁴	1.00 in ²
EXTRA HEAVY DUTY - VERY LONG SPAN TRAYS - SOLID OR VENTILATED BOTTOMS											
		2D62	2D63	2D6U	-	6" (152mm)	6 ¼" (159mm)	1 ¼"	3.056 in ³	9.270 in ⁴	1.50 in ²
		11D62	11D63	11D6U	-	6" (152mm)	6 ¼" (159mm)	1 ¼"	3.536 in ³	10.630 in ⁴	1.50 in ²



Steel Tray

Load and Deflection Data For Steel. Trof Working (Allowable) Load Capacity, Evenly Distributed - Tested per NEMA Standard VE-1. Span (Ft.) - Simple Beam - SAFETY FACTOR: 1.5

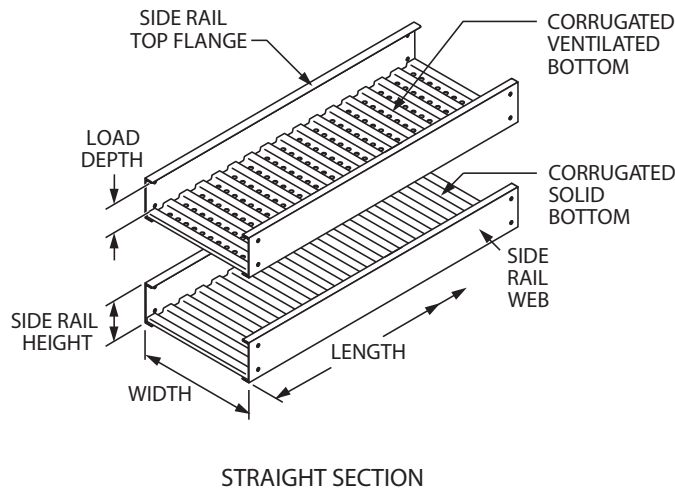
Cope Sys. No.	6 Ft. Span			8 Ft. Span			10 Ft. Span			12 Ft. Span			16 Ft. Span			20 Ft. Span			24 Ft. Spa			25 Ft. Span		
	w	d	k	w	d	k	w	d	k	w	d	k	w	d	k	w	d	k	w	d	k	w	d	k
8232/3/U	230	.30	.001	126	.52	.004	79	.79	.010	53	1.11	.021												
8242/3/U	292	.23	†	164	.42	.003	103	.63	.006	69	.89	.013												
8252/3/U	383	.18	†	210	.31	.001	127	.46	.004	83	.62	.007												
8262/3/U	357	.11	†	194	.18	†	119	.28	.002	79	.38	.005												
4232/3/U	358	.30	†	197	.53	.003	124	.81	.007	83	1.13	.014												
8842/3/U	360	.26	†	198	.46	.002	124	.70	.006	84	.98	.012												
8252/3/U	383	.18	†	210	.31	.001	127	.46	.004	83	.62	.007												
8262/3/U	357	.11	†	194	.18	†	119	.28	.002	79	.38	.005												
6B42/3/U	453	.27	†	249	.47	.002	156	.71	.005	106	1.00	.009												
6B52/3/U	591	.21	†	325	.36	.001	203	.55	.003	137	.77	.006												
6262/3/U	460	.11	†	250	.19	†	154	.29	.002	103	.40	.004												
8D42/3/U				290	.53	.002	182	.81	.004	126	1.17	.009	65	1.91	.029									
6452/3/U				444	.42	†	273	.63	.002	186	.89	.005	100	1.51	.015									
6462/3/U				574	.42	†	367	.55	.001	245	.76	.003	123	1.22	.010									
6D42/3/U				381	.56	.001	244	.88	.004	169	1.27	.008	88	2.08	.024									
6452/3/U				444	.42	†	273	.63	.002	186	.89	.005	100	1.51	.015									
6462/3/U				574	.42	†	367	.55	.001	245	.76	.003	123	1.22	.010									
4D42/3/U				487	.58	.001	312	.91	.003	216	1.31	.006	113	2.16	.019									
6452/3/U				444	.42	†	273	.63	.002	186	.89	.005	100	1.51	.015									
6462/3/U				574	.42	†	367	.55	.001	245	.76	.003	123	1.22	.010									
6D42/3/U										169	1.27	.008	88	2.08	.024	52	2.98	.057						
6452/3/U										186	.89	.005	100	1.51	.015	53	1.94	.037						
6462/3/U										245	.76	.003	123	1.22	.010	66	1.59	.024						
2D42/3/U										304	1.36	.004	159	2.24	.014	94	3.23	.034						
4D52/3/U										280	1.02	.004	145	1.67	.012	85	2.40	.028						
6D62/3/U										269	.80	.003	139	1.28	.009	81	1.82	.022						
2D52/3/U										395	1.05	.003	206	1.74	.008	121	2.50	.021						
4D62/3/U										296	.79	.003	152	1.28	.008	105	1.91	.018						
EXTRA HEAVY DUTY - VERY LONG SPAN TRAYS - SOLID OR VENTILATED BOTTOMS																								
2D62/3/U										390	.85	.002	221	1.40	.006	149	2.00	.013	79	1.91	.024	73	2.38	.033
11D62/3/U										434	.66	†	244	1.17	.005	156	1.82	.012	108	2.62	.024	100	2.85	.029

Note: To convert 1.5 safety factor to 2.0 multiply w, d, k by .75
w = Pounds per linear foot
Metric: for kg/m multiply by 1.48
d = Deflection (inches)
k = Deflection (in.) for each pound of load
† = Denotes k is less than .001 inch

FEATURES
SWAGE
I-BEAM
TROF
EAGLE BASKET
CHANNEL
GLAS
AICKINSTRUT
DATA

Overview

Cope Trof is a prefabricated metal structure consisting of ventilated or solid bottoms, welded to the side rails, and is manufactured and tested to NEMA Standard VE-1. Straight sections, fittings (elbows, tees, crosses, reducers, etc.) and a full line of matching and interfacing accessories are available. Corrugations give great lateral rigidity to the bottom transmitting the load to the side rails. Lateral (transverse) deflection is nearly eliminated compared to rung type trofs where the rails are not continuously braced by the bottom.



Cope Corrugated bottoms do NOT limit the tray load capacity. Corrugated bottoms have 1" wide ribs on 2" centers. Ventilation holes in the valleys of the corrugations are 1/16" diameter on one inch (1") centers. Free passage of air through the openings results in a 68% open area at the elevated cable support surface on top of ribs. Solid Trof have the same corrugations but have no holes.

Note: Where drain holes are required, one can be placed in the center of each valley, if specified.

Cope Trof with Three Important Industry-Leading Features:

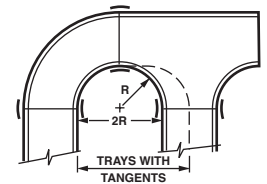
1. New Universal Curvilinear Splice Plate System

The splice plates for rigid connections have a slight curve so they can be used on straight sections or fittings. Tightening of the fastener pulls the plate flush with the side rail. The fasteners are snug and the joint is structurally and electrically superior. Even when hand-tightened, there is pressure on the fastener to hold it securely.

Note: Heavy Duty, Mid-Span Splice Plates available upon request.

2. Zero Tangent Fittings

Tangent as referred to on cable tray fittings is the straight at the end of the curve to accommodate a flat splice plate. This wastes space in tightly packed areas, such as spreader rooms, where the heat of thousands of cables accumulate. Eliminating tangents allows more tray runs to distribute the heat. Cope Zero Tangent Fittings can save up to 12" per row of tray.



BONUS: Inspection for proper installation of splice plate is visual. If the plate is bowed away from the rail, nuts must be tightened.

3. The Exclusive Auto Arc-Welded Assembly System

Corrugated bottoms on straight sections are assembled to the side rails using an automatic, self indexing MIG-arc-welding system fusing a ½" diameter zone. These welds are 700% larger and stronger than the common resistance (spot) weld in use today. Electrical properties of the assembly are unequaled and are well within the NEMA requirements due to the continuous electrical path. The mechanical strength of this welded assembly withstands the rigors of shipping, handling, installation and service. The size of the weld keeps the vertical axis of the side rail from sloping inward under load. The weld maintains the 90° angle between the side rail and bottom. This allows full use of the section properties. Spot welds do not permit this. Also, stresses on spot welds (barely ⅛" diameter) are so severe that breakage often occurs during shipping and installation. Cope Trof fittings are also assembled by MIG-arc-welding.

Uses of Cope Trof

Generally, Cope Trof is optimum for ANY size cable. It offers continuous support with or without ventilation. The bottom design offers safety and security from unauthorized personnel. The vent holes may be bushed with a grommet for dropping out communication cables (Catalog # DOG-1).



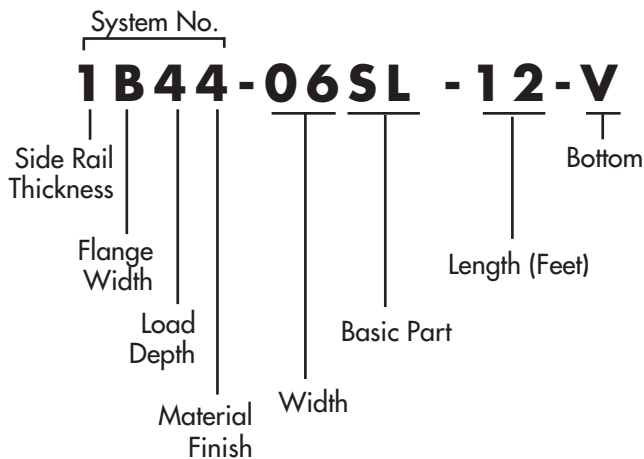
Part Numbering System

Part Numbering System:

Please pay careful attention to the part numbering structure.

Example: Catalog # 1B44-06SL-12-V is a 4" load depth aluminum tray with $1\frac{3}{16}$ " flange, 6" wide, straight length 12' long, with ventilated bottom. Please make sure you use the system numbers from pages 86 - 89.

Straight Length



System Number (Straight Section Only)

The first four digits make up the system number which identifies the structural, dimensional, and material characteristics of the straight length. It is made up of the side rail digits indicating the side rail thickness and flange width, the load depth (inside, in inches), and material finish (galvanized, aluminum or coated).

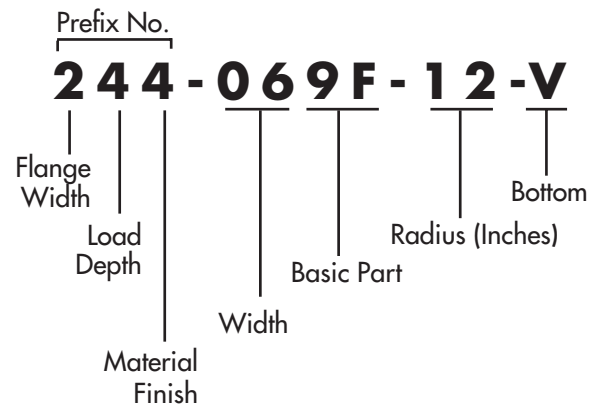
Prefix Number (Fittings Only)

Fittings are ordered using the 3-digit prefix number given in the charts on the fitting pages. Fittings do not have stiffened upper flanges.

Width

Identifies the inside width of the tray in inches.

Fittings



Basic Part Number

Identifies the straight length, fitting, or accessory.

Secondary Dimension Number

Identifies the length of a straight section in feet, the radius of a fitting in inches, or the second width of a reducer in inches.

Bottom Type

Identifies the type bottom: V (Ventilated) or S (Solid). Example: 1B44-06SL-12-V is a 4" load depth aluminum Trof with a $1\frac{3}{16}$ " flange, 6" wide, straight length 12' long with a ventilated bottom.

Straight Length System Number

Thickness Steel	Flange Width		Load Depth		Material Finish
8 - 18 ga.	2 - 1 ³ / ₁₆ "	21mm	3"	76mm	2 - Mill-Galv.
6 - 16 ga.	4 - 1 ¹ / ₄ "	32mm	4"	102mm	3 - HDGAF
4 - 14 ga.	7 - 2"	51mm	5"	127mm	4 - Aluminum
2 - 12 ga.			6"	152mm	U - 304SS
11 - 11 ga.					
Thickness Alum					
1" - Thinner	B* - 1 ³ / ₁₆ "	21mm			
3" -	D* - 1 ¹ / ₄ "	32mm			
5" -**	G* - 2"	51mm			
7" -					
9" - Thicker					

*Stiffened Upper Flange

**Alum. extruded side rails are individually engineered to loads and spans.

Note: Slotted Rungs or Solid Rungs available on all widths.

Description Fittings

Width		Basic Part Number	Length	Bottom
06=6"	152mm	SL (Straight Len.)	- 12' 3.7m	-V (ventilated)
09=9"	229mm	9F (90° Horiz. El.)	- 24' 7.3m	-S (solid)
12=12"	305mm	6F (60° Horiz. El.)	- 10' 3m, CSA	
18=18"	457mm	4F (45° Horiz. El.)	- 20' 6m, CSA	
24=24"	610mm	3F (30° Horiz. El.)		
30=30"	762mm	90 (90° Out. Vert.El.)		
36=36"	914mm	60 (60° Out. Vert. El.)		
		40 (45° Out. Vert. El.)		Radius
		30 (30° Out. Vert. El.)		12=12" 305mm
		9I (90° In. Vert. El.)		24=24" 610mm
		6I (60° In. Vert. El.)		36=36" 914mm
		4I (45° In. Vert. El.)		
		3I (30° In. Vert. El.)		
		FT (Horiz. Tee)		
		FC (Horiz. Cross)		
		VT (Vert. Tee)		
		SR (Vert. Cable Support Elbow)		
		ST (Straight Reducer)		
		RH (Right Hand Reducer)		
		LH (Left Hand Reducer)		
		AF (Adjustable Elbow)		
		RY & LY (45° Y Branch)		

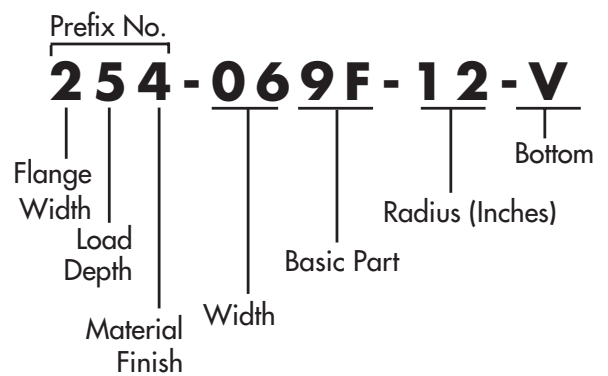
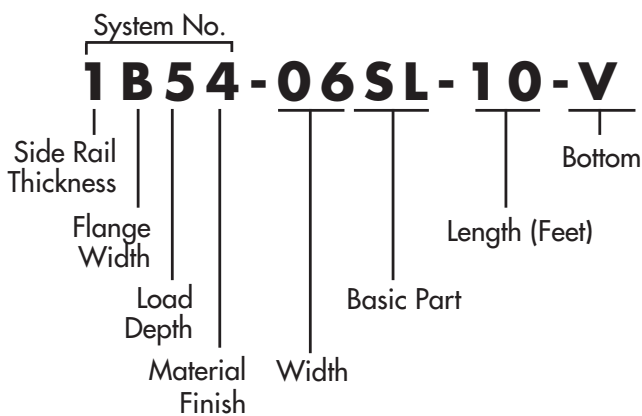


CSA Ordering Information

Cope CSA Standards C22-2 Cable Trof Ventilated & Solid Bottom Type

How To Order:

Explanation of Cope's Canadian Standards cable tray catalog # is described below. Use the system numbers given in selection charts for straight sections, or the fitting prefix numbers given in fitting tables. Be sure to follow system number or the fitting prefix with the item description number.



System Number (Straight Section Only)

The first four digits make up the system number which identifies the structural, dimensional, and material characteristics of the straight length. It is made up of the side rail digits indicating the side rail thickness and flange width, the load depth (inside, in inches), and material finish (galvanized, aluminum or coated).

Prefix Number (Fittings Only)

Fittings are ordered using the 3-digit prefix number given in the charts on the fitting pages. Fittings do not have stiffened upper flanges.

Width

Identifies the inside width of the tray (in inches).

Basic Part Number

Identifies the straight length, fitting, or accessory.

Secondary Dimension Number

Identifies the length of a straight section (in feet), the radius of a fitting (in inches), or the second width of a reducer (in inches).

Bottom Type

Identifies the type bottom: V (Ventilated) or S (Solid)





FEATURES

SWAGE

I-BEAM

TROF

EAGLE BASKET

CHANNEL

GLAS

AICKINSTRUT

DATA

CSA Straight Length System Number

Thickness Steel	Flange Width	Load Depth	Material Finish
8 - 18 ga.	2 - 1 ³ / ₁₆ " 21mm	4" 102mm	2 - Mill-Galv
6 - 16 ga.	4 - 1 1/4" 32mm	5" 127mm	3 - HDGAF, CSA Class 1
4 - 14 ga.		6" 152mm	4 - Aluminum Plain Finish
Thickness Alum (in.)**			
1" - thinner	*B - 1 ³ / ₁₆ " 21mm		
3" -	*D - 1 1/4" 32mm		
5" - **			
7" -			
9" - thicker			

* Stiffened Upper Flange

**Alum. extruded side rails are individually engineered to loads and spans.

Description Fittings

Width	Basic Part No.	Length	Bottom
06=6"	152mm	SL (Straight Length)	10-10' 3.05m
09=9"	229mm	9F (90° Horiz. Elbow)	20-20' 6.10m
12=12"	305mm	6F (60° Horiz. Elbow)	
18=18"	457mm	4F (45° Horiz. Elbow)	
24=24"	610mm	3F (30° Horiz. Elbow)	
30=30"	762mm	90 (90° Out. Vert. Elbow)	
36=36"	914mm	60 (60° Out. Vert. Elbow)	
		40 (45° Out. Vert. Elbow)	
		30 (30° Out. Vert. Elbow)	
		9I (90° In. Vert. Elbow)	Radius
		6I (60° In. Vert. Elbow)	12 = 12" 305mm
		4I (45° In. Vert. Elbow)	24 = 24" 610mm
		3I (30° In. Vert. Elbow)	36 = 36" 915mm
		FT (Horiz. Tee)	
		FC (Horiz. Cross)	
		VT (Vert. Tee)	
		SR (Vert. Cable Support Elbow)	
		ST (Straight Reducer)	
		RH (Right Hand Reducer)	
		LH (Left Hand Reducer)	
		AF (Adjustable Elbow)	
		RY & LY (45° Y Branch)	
		AF (Adjustable Elbow)	
		RY & LY (45° Y Branch)	

Cope Cable Trof

CSA System Selection Chart

The list below gives the CSA certified items carrying the CSA label.



Certified Cope Systems That Meet Performance Class CSA Std.C22.2

CSA Class	Cope System	Load Depth	Side Rail	Flange Width	Max. Load Kg/m (lb/ft)	Maximum Support Span	Deflection at Max Support Span	Meets CSA Elec. Tests
ALUMINUM TROF TRAY - Safety Factor: 1.5								
C	1B44	4" (102mm)	4 ¼" (108mm)	1 ⅜" (21mm)	97 (65)	3m	25.1mm	Yes
20A	3D44	4" (102mm)	4 ¼" (108mm)	1 ¼" (32mm)	74 (50)	6m (1)	108.5mm	Yes
16C	5D44	4" (102mm)	4 ¼" (108mm)	1 ¼" (32mm)	149 (100)	4m.9	71.4mm	Yes
20C	5E44	4" (102mm)	4 ¼" (108mm)	1 ½" (38mm)	149 (100)	6m (1)	121.7mm	Yes
C	1B54	5" (127mm)	5 ¼" (133mm)	1 ⅜" (21mm)	97 (65)	3m	22.1mm	Yes
20A	7454	5" (127mm)	5 ¼" (133mm)	1 ¼" (32mm)	74 (50)	6m (1)	73.4mm	Yes
20B	3D54	5" (127mm)	5 ¼" (133mm)	1 ¼" (32mm)	112 (75)	6m (1)	78.7mm	Yes
20A	1D64	6" (152mm)	6 ¼" (159mm)	1 ¼" (32mm)	74 (50)	6m (1)	63.8mm	Yes
20C	7D64	6" (152mm)	6 ¼" (159mm)	1 ¼" (32mm)	149 (100)	6m (1)	76.7mm	Yes
Mil Galv. STEEL TROF TRAY Safety Factor: 1.5								
C	8242	3 ¾" (95mm)	4 ¼" (108mm)	1 ⅜" (21mm)	97 (65)	3m	16.0mm	Yes
20A	6452	5" (127mm)	5 ¼" (133mm)	1 ¼" (32mm)	74 (50)	6m (1)	49.3mm	Yes
20B	4D52	5" (127mm)	5 ¼" (133mm)	1 ¼" (32mm)	112 (75)	6m (1)	61.0mm	Yes
12B	8262	6" (152mm)	6 ¼" (159mm)	1 ⅜" (21mm)	112 (75)	3.7m	9.7mm	Yes
20A	6462	6" (152mm)	6 ¼" (159mm)	1 ¼" (32mm)	74 (50)	6m (1)	40.4mm	Yes
20C	4D62	6" (152mm)	6 ¼" (159mm)	1 ¼" (32mm)	149 (100)	6m	48.5mm	Yes
HDGAF STEEL TROF TRAY Safety Factor: 1.5								
C	8243	3 ¾" (95mm)	4 ¼" (108mm)	1 ⅜" (21mm)	97 (65)	3m	16.0mm	Yes
20A	6453	5" (127mm)	5 ¼" (133mm)	1 ¼" (32mm)	74 (50)	6m (1)	49.3mm	Yes
20B	4D53	5" (127mm)	5 ¼" (133mm)	1 ¼" (32mm)	112 (75)	6m (1)	61.0mm	Yes
12B	8263	6" (152mm)	6 ¼" (159mm)	1 ⅜" (21mm)	112 (75)	3.7m	9.7mm	Yes
20A	6463	6" (152mm)	6 ¼" (159mm)	1 ¼" (32mm)	74 (50)	6m (1)	40.4mm	Yes
20C	4D63	6" (152mm)	6 ¼" (159mm)	1 ¼" (32mm)	149 (100)	6m	48.5mm	Yes

Notes: (1) Also recommended for 3 meter support spans
 Note: indicates most common systems. Consult factory for lead times on other systems.

CSA Loads

Identify the desired load designation needed for your project from the chart below. Both CSA Class and NEMA designations are listed by load capability and span. Then, select the CSA Certified Cope System from the table above. Where CSA C22.2 is not mandatory, you may want to consider one of the other Cope systems offered on the selection charts (page 92 - 95).

Historical Load/Span Class Designation

Load, kg/m (lb/ft)	Span, m (ft)				
	2.4 (8)	3.0 (10)	3.7 (12)	4.9 (16)	6.0 (20)
37 (25)	-	A	-	-	-
67 (45)	-	-	-	-	D
74 (50)	8A	-	12A	16A	20A
97 (65)	-	C	-	-	-
112 (75)	8B	-	12B	16B	E or 20B
149 (100)	8C	-	12C	16C	20C
179 (120)	-	D	-	-	-
299 (200)	-	E	-	-	-

Note: 8A/B/C, 12A/B/C, 16A/B/C, and 20A/B/C have been NEMA designations. A, B, C, D and E are CSA designations.

Receiving, Installing, and Maintenance

The proper care and handling of cable Trofs by the receiver and installers is very important to ensure a safe installation that will meet the intended service life. Cope has an installation guide available to assist the installers and those who will maintain the installed system.

Dimensions and Structural Properties: Cope CSA Systems

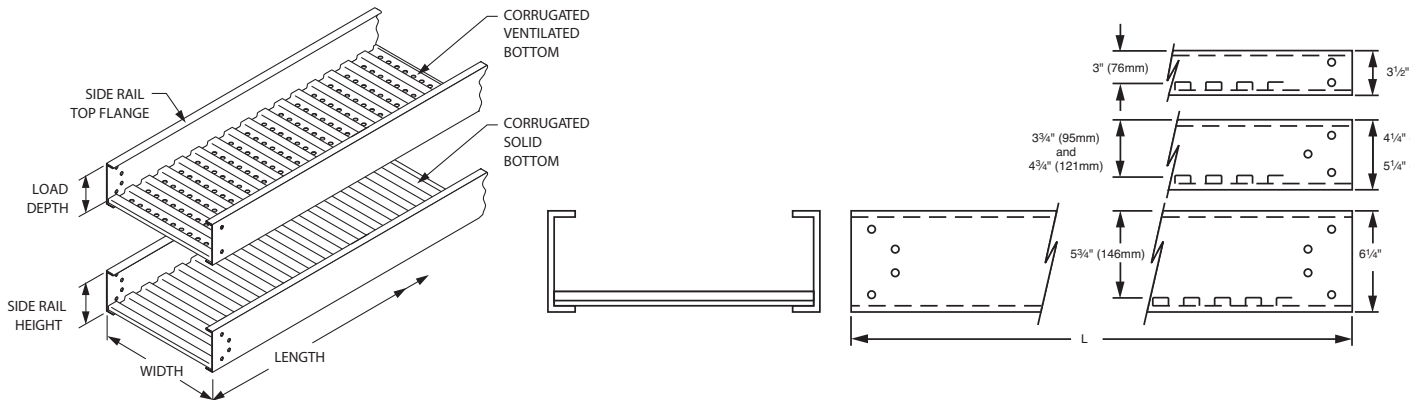
The performance of the Cope cable Trof systems certified by CSA is given above. Structural properties of straight sections, though not required to be listed, are given in the Cope NEMA selection charts, in English units. Dimensions of straight sections and certified fittings are furnished in English and metric units for use in layout and/or entry into computerized systems.

Note: For other CSA approved systems please contact the factory at CopeMarketing@atkore.com



TROF

Straight Length [SL]



Cope Trof is manufactured in 10' (CSA), 12', 20' (CSA) and 24' lengths; 6", 9", 12", 18", 24", 30" and 36" widths; and 3", 4", 5", and 6" nominal load depths. A complete line of fittings and accessories are available.

Corrugated bottoms have 1" wide ribs on 2" centers. Ventilation holes in the valleys of the corrugations are 1¹/₁₆" diameter on 1" centers.

Catalog

System	Width	Basic No.	Length	Bottom Type
See Pages 86 to 89	-06=6" (152mm)	SL	NEMA	-S (solid) -V (ventilated)
	-09=9" (229mm)		12' (3.7m)*	
	-12=12" (305mm)		24' (7.3m)*	
	-18=18" (457mm)		10' (3m)*	
	-24=24" (610mm)		20' (6m)*	
	-30=30" (762mm)		CSA	
	-36=36" (914mm)		-10' (3m)	
			-20' (6m)	

*10', 12' all NEMA Classes, 20', 24' NEMA Classes 16A, 16B, 16C, 20A, 20B, 20C.
Example: 1B44-06SL-12-V is a 4" load depth aluminum Trof with 1³/₁₆" flange, 6" wide, 12' long, with ventilated bottom.

Material & Finish Specifications (Cope Trof)

	Pre-Galvanized Steel	Hot-Dip Galvanized After Fabrication ASTM A-123	Aluminum	Type 304 Stainless Steel
Siderails	ASTM A-653-G90 CS (18 & 16 Gauge) ASTM A-653-G90 CS (14 & 12 Gauge)	ASTM A-1008 (18 & 16 Gauge) ASTM A-1011 (14 & 12 Gauge)	AA-6063-T6 Extruded	ASTM A-240; Type 304
Bottom	ASTM A-653-G90 CS	ASTM A-1008	AA-6063-H34	ASTM A-269; Type 304
Splice Plate Finish	ASTM A-1011	ASTM A-1011	AA-5052-H34	ASTM A-240; Type 304
	ASTM A-591 Class C	ASTM A-123 Grade 65	2B Finish (Typical)	
Connector	SAE J429 Grade 1	SAE J429 Grade 1	SAE J429 Grade 1	
Bolts	(ASTM A-307 Grade A)	(ASTM A-307 Grade A)	(ASTM A-307 Grade A)	AISI Type 304 Stainless Steel
Bolt Plating	ASTM B-633.0002 Zinc	ASTM B-633.0002 Zinc	ASTM B-633.0002 Zinc	
Covers	ASTM A-653-G90 CQ	ASTM A-653-G90 CQ	AA-3003 H14 or 3150 H14	ASTM A-240; Type 304

Free passage of air through the openings results in a 68% open area. Corrugations give great lateral rigidity to the bottom transmitting the load to the side rails.

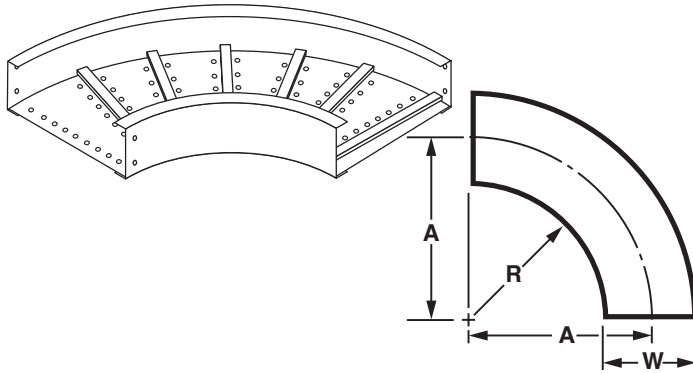
Solid Trof have the same corrugations but have no holes. Materials: Aluminum, Hot Dip, Mill-galvanized (pre-galvanized) to ASTM A-924, Hot Dip Galvanized after Fabrication (HDGAF) to ASTM A-123.

Sufficient connectors are supplied to assemble straight sections and fittings for each order. Connectors for field cuts are to be ordered separately.

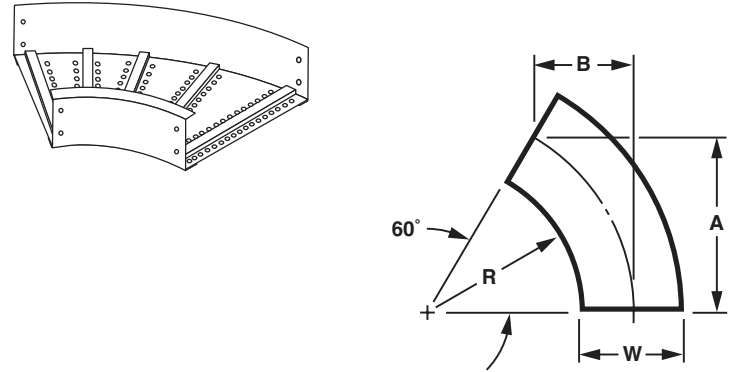
Conversion Table

English	6"	9"	12"	18"	24"	30"	36"	12'-0	24'-0	10'-0	20'-0
Metric (mm)	152	229	305	457	610	762	914	3658	7316	3048	6096

90° Horizontal Elbow [9F]



60° Horizontal Elbow [6F]

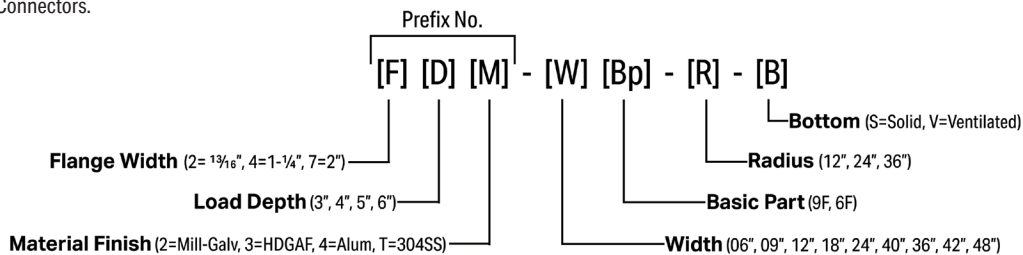


Radius - R	Width - W	A Dimension
12" (305mm)	6" (152mm)	15" (381mm)
	9" (229mm)	16 1/2" (419mm)
	12" (305mm)	18" (457mm)
	18" (457mm)	21" (533mm)
	24" (610mm)	24" (610mm)
	30" (762mm)	27" (686mm)
	36" (914mm)	30" (762mm)
24" (610mm)	6" (152mm)	27" (686mm)
	9" (229mm)	28 1/2" (724mm)
	12" (305mm)	30" (762mm)
	18" (457mm)	33" (838mm)
	24" (610mm)	36" (914mm)
	30" (762mm)	39" (991mm)
	36" (914mm)	42" (1067mm)
36" (914mm)	6" (152mm)	39" (991mm)
	9" (229mm)	40 1/2" (1029mm)
	12" (305mm)	42" (1067mm)
	18" (457mm)	45" (1143mm)
	24" (610mm)	48" (1219mm)
	30" (762mm)	51" (1295mm)
	36" (914mm)	54" (1372mm)

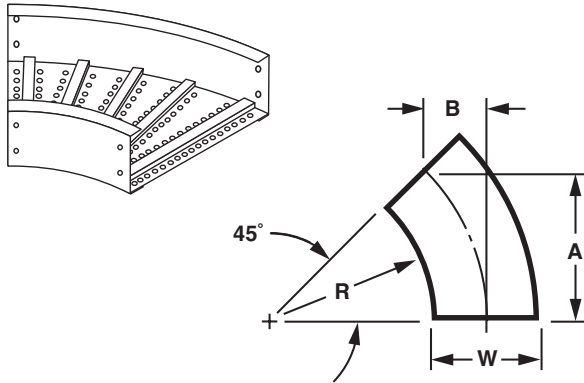
Radius - R	Width - W	A Dimension	B Dimension
12" (305mm)	6" (152mm)	13" (330mm)	7 1/2" (191mm)
	9" (229mm)	14 1/4" (362mm)	8 1/4" (210mm)
	12" (305mm)	15 5/8" (397mm)	9" (229mm)
	18" (457mm)	18 1/4" (464mm)	10 1/2" (267mm)
	24" (610mm)	20 3/4" (527mm)	12" (305mm)
	30" (762mm)	23 3/8" (594mm)	13 1/2" (343mm)
	36" (914mm)	26" (660mm)	15" (381mm)
24" (610mm)	6" (152mm)	23 3/8" (594mm)	13 1/2" (343mm)
	9" (229mm)	24 3/4" (629mm)	14 1/4" (362mm)
	12" (305mm)	26" (660mm)	15" (381mm)
	18" (457mm)	28 5/8" (727mm)	16 1/2" (416mm)
	24" (610mm)	31 1/4" (794mm)	18" (457mm)
	30" (762mm)	33 3/4" (857mm)	19 1/2" (495mm)
	36" (914mm)	36 3/8" (924mm)	21" (533mm)
36" (914mm)	6" (152mm)	33 3/4" (857mm)	19 1/2" (495mm)
	9" (229mm)	35 1/8" (892mm)	20 1/4" (514mm)
	12" (305mm)	36 3/8" (924mm)	21" (533mm)
	18" (457mm)	39" (991mm)	22 1/2" (572mm)
	24" (610mm)	41 5/8" (1057mm)	24" (610mm)
	30" (762mm)	44 1/8" (1121mm)	25 1/2" (648mm)
	36" (914mm)	46 3/4" (118mm)	27" (686mm)

*Add Suffix -V (Ventilated) or -S (solid) to catalog #
 Example: 234-129F-12-V
 Note: When small or in-between angles are needed,
 use Cope's Adjustable Connectors.

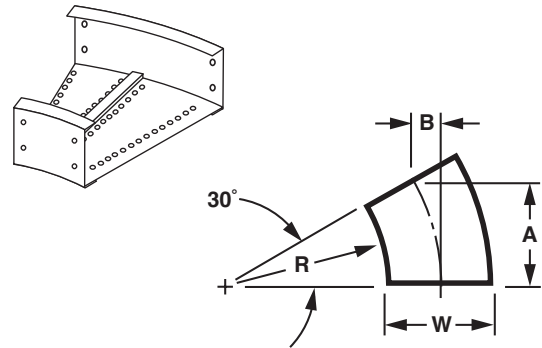
*Add suffix -V (Ventilated) or -S (solid) to catalog #
 Example: 234-126F-12-V



45° Horizontal Elbow [4F]



30° Horizontal Elbow [3F]

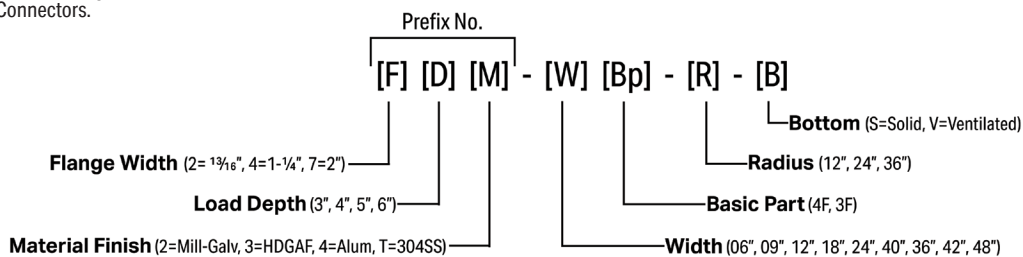


Radius - R	Width - W	A Dimension	B Dimension
12" (305mm)	6" (152mm)	10 5/8" (270mm)	4 3/8" (111mm)
	9" (229mm)	11 5/8" (295mm)	4 7/8" (124mm)
	12" (305mm)	12 3/4" (324mm)	5 1/4" (133mm)
	18" (457mm)	14 7/8" (378mm)	6 1/8" (156mm)
	24" (610mm)	17" (432mm)	7" (178mm)
	30" (762mm)	19 1/8" (486mm)	7 7/8" (200mm)
	36" (914mm)	21 1/4" (540mm)	8 3/4" (222mm)
24" (610mm)	6" (152mm)	19 1/8" (486mm)	7 7/8" (200mm)
	9" (229mm)	20 1/8" (511mm)	8 3/8" (213mm)
	12" (305mm)	21 1/4" (540mm)	8 3/4" (222mm)
	18" (457mm)	23 3/8" (594mm)	9 5/8" (244mm)
	24" (610mm)	25 1/2" (702mm)	10 1/2" (267mm)
	30" (762mm)	27 5/8" (702mm)	11 1/2" (292mm)
	36" (914mm)	29 3/4" (756mm)	12 3/8" (314mm)
36" (914mm)	6" (152mm)	27 5/8" (702mm)	11 1/2" (292mm)
	9" (229mm)	28 5/8" (727mm)	11 7/8" (302mm)
	12" (305mm)	29 3/4" (756mm)	12 3/8" (314mm)
	18" (457mm)	31 7/8" (810mm)	13 1/4" (337mm)
	24" (610mm)	34" (864mm)	14 1/8" (359mm)
	30" (762mm)	36 1/8" (918mm)	15" (381mm)
	36" (914mm)	38 1/4" (972mm)	15 7/8" (403mm)

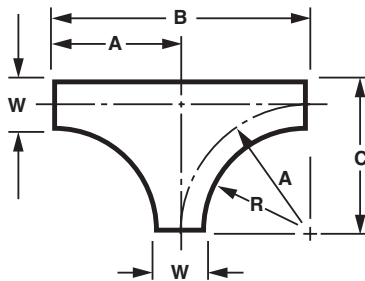
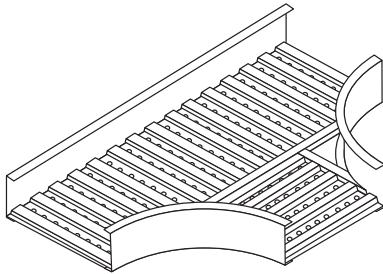
Radius - R	Width - W	A Dimension	B Dimension
12" (305mm)	6" (152mm)	7 1/2" (191mm)	2" (51mm)
	9" (229mm)	8 1/4" (210mm)	2 1/4" (57mm)
	12" (305mm)	9" (229mm)	2 3/8" (60mm)
	18" (457mm)	10 1/2" (267mm)	2 7/8" (73mm)
	24" (610mm)	12" (305mm)	3 1/4" (83mm)
	30" (762mm)	13 1/2" (343mm)	3 5/8" (92mm)
	36" (914mm)	15" (381mm)	4" (102mm)
24" (610mm)	6" (152mm)	13 1/2" (343mm)	3 5/8" (92mm)
	9" (229mm)	14 1/4" (362mm)	3 7/8" (98mm)
	12" (305mm)	15" (381mm)	4" (102mm)
	18" (457mm)	16 1/2" (419mm)	4 3/8" (111mm)
	24" (610mm)	18" (457mm)	4 7/8" (124mm)
	30" (762mm)	19 1/2" (495mm)	5 1/4" (133mm)
	36" (914mm)	21" (533mm)	5 5/8" (143mm)
36" (914mm)	6" (152mm)	19 1/2" (495mm)	5 1/4" (133mm)
	9" (229mm)	20 1/4" (514mm)	5 1/2" (140mm)
	12" (305mm)	21" (533mm)	5 5/8" (143mm)
	18" (457mm)	22 1/2" (572mm)	6" (152mm)
	24" (610mm)	24" (610mm)	6 1/2" (165mm)
	30" (762mm)	25 1/2" (648mm)	6 7/8" (175mm)
	36" (914mm)	27" (686mm)	7 1/4" (184mm)

*Add suffix -V (Ventilated) or -S (solid) to catalog #
Example: 234-124F-12-V
Note: When small or in-between angles are needed,
use Cope's Adjustable Connectors.

*Add suffix -V (Ventilated) or -S (solid) to catalog #
Example: 234-123F-12-V



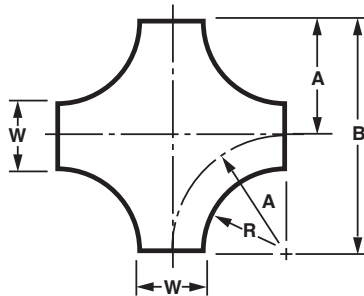
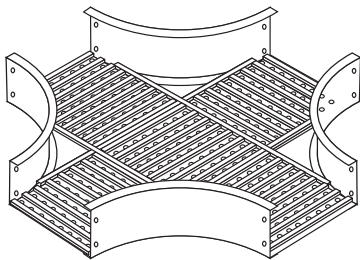
Horizontal Tee [FT]



Radius - R	Width - W	A Dimension	B Dimension	C Dimension
12" (305mm)	6" (152mm)	15" (381mm)	30" (762mm)	18" (457mm)
	9" (229mm)	16 1/2" (419mm)	33" (838mm)	21" (533mm)
	12" (305mm)	18" (457mm)	36" (914mm)	24" (610mm)
	18" (457mm)	21" (533mm)	42" (1067mm)	30" (762mm)
	24" (610mm)	24" (610mm)	48" (1219mm)	36" (914mm)
	30" (762mm)	27" (686mm)	54" (1372mm)	42" (1067mm)
24" (610mm)	6" (152mm)	27" (686mm)	54" (1372mm)	30" (762mm)
	9" (229mm)	28 1/2" (724mm)	57" (1448mm)	33" (838mm)
	12" (305mm)	30" (762mm)	60" (1524mm)	36" (914mm)
	18" (457mm)	33" (838mm)	66" (1676mm)	42" (1067mm)
	24" (610mm)	36" (914mm)	72" (1829mm)	48" (1219mm)
	30" (762mm)	39" (991mm)	78" (1981mm)	54" (1372mm)
36" (914mm)	6" (152mm)	39" (991mm)	78" (1981mm)	42" (1067mm)
	9" (229mm)	40 1/2" (1029mm)	81" (2057mm)	45" (1143mm)
	12" (305mm)	42" (1067mm)	84" (2134mm)	48" (1219mm)
	18" (457mm)	45" (1143mm)	90" (2286mm)	54" (1372mm)
	24" (610mm)	48" (1219mm)	96" (2438mm)	60" (1524mm)
	30" (762mm)	51" (1295mm)	102" (2591mm)	66" (1676mm)
36" (914mm)	54" (1372mm)	108" (2743mm)	72" (1829mm)	

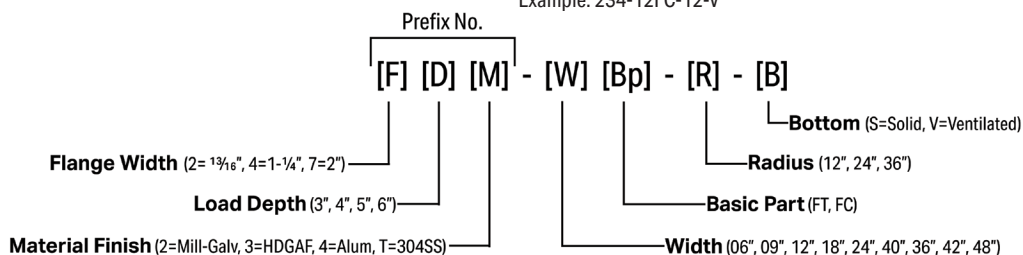
* Add suffix -V (Ventilated) or -S (solid) to catalog # - Example: 234-12FT-12-V

Horizontal Cross [FC]

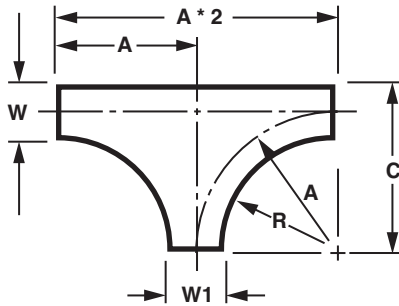
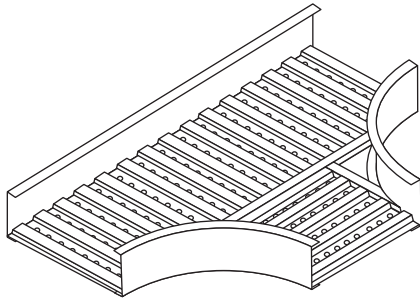


Radius - R	Width - W	A Dimension	B Dimension
12" (305mm)	6" (152mm)	15" (381mm)	30" (762mm)
	9" (229mm)	16 1/2" (419mm)	33" (838mm)
	12" (305mm)	18" (457mm)	36" (914mm)
	18" (457mm)	21" (533mm)	42" (1067mm)
	24" (610mm)	24" (610mm)	48" (1219mm)
	30" (762mm)	27" (686mm)	54" (1372mm)
24" (610mm)	6" (152mm)	27" (686mm)	54" (1372mm)
	9" (229mm)	28 1/2" (724mm)	57" (1448mm)
	12" (305mm)	30" (762mm)	60" (1524mm)
	18" (457mm)	33" (838mm)	66" (1676mm)
	24" (610mm)	36" (914mm)	72" (1829mm)
	30" (762mm)	39" (991mm)	78" (1981mm)
36" (914mm)	6" (152mm)	39" (991mm)	78" (1981mm)
	9" (229mm)	40 1/2" (1029mm)	81" (2057mm)
	12" (305mm)	42" (1067mm)	84" (2134mm)
	18" (457mm)	45" (1143mm)	90" (2286mm)
	24" (610mm)	48" (1219mm)	96" (2438mm)
	30" (762mm)	51" (1295mm)	102" (2591mm)
36" (914mm)	54" (1372mm)	108" (2743mm)	

*Add suffix-V (Ventilated) or -S (solid) to catalog #
Example: 234-12FC-12-V

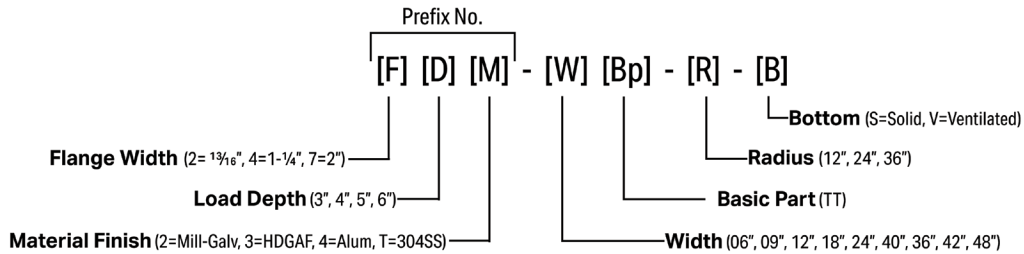


Horizontal Tapped Tee [TT]



R Radius	W Width	W1 Width	A Dimension	C Dimension
36" (914mm)		30" (762mm)	27" (686mm)	48" (1219mm)
		24" (610mm)	24" (610mm)	
		18" (457mm)	21" (533mm)	
		12" (305mm)	18" (457mm)	
		9" (229mm)	16 ½" (419mm)	
30" (762mm)		24" (610mm)	24" (610mm)	42" (1067mm)
		18" (457mm)	21" (533mm)	
		12" (305mm)	18" (457mm)	
		9" (229mm)	16 ½" (419mm)	
12" (305mm)		18" (457mm)	21" (533mm)	36" (914mm)
		12" (305mm)	18" (457mm)	
		9" (229mm)	16 ½" (419mm)	
18" (457mm)		12" (305mm)	18" (457mm)	30" (762mm)
		9" (229mm)	16 ½" (419mm)	
12" (305mm)		9" (229mm)	16 ½" (419mm)	24" (610mm)
		6" (152mm)	15" (381mm)	
9" (229mm)		6" (152mm)	15" (381mm)	21" (533mm)

* Add Suffix -V (Ventilated) or -S (solid) to catalog #
Example: 234-12TT-12-V

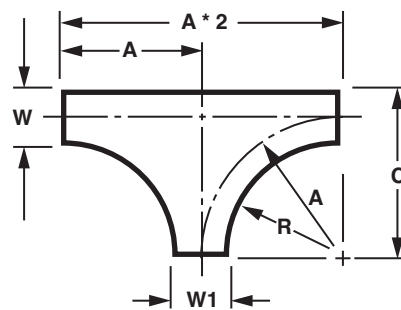
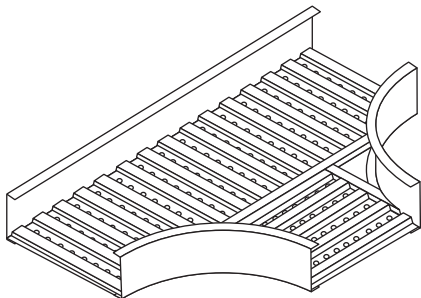


Horizontal Tapped Tee [TT] (cont.)

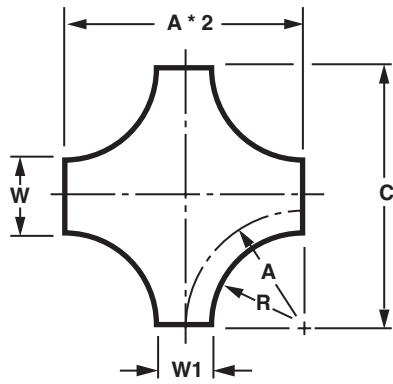
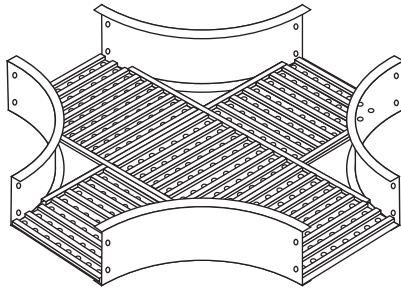


R Radius	W Width	W1 Width	A Dim.	C Dim.	R Radius	W Width	W1 Width	A Dim.	C Dim.			
24" (610mm)	36" (914mm)	30" (762mm)	39" (991mm)	60" (1524mm)	36" (914mm)	30" (762mm)	51" (1295mm)	72" (1829mm)				
		24" (610mm)	36" (914mm)			48" (1219mm)						
		18" (457mm)	33" (838mm)			45" (1143mm)						
		12" (305mm)	30" (762mm)			42" (1067mm)						
		9" (229mm)	28 1/2" (724mm)			40 1/2" (1029mm)						
		6" (152mm)	27" (686mm)			39" (991mm)						
	30" (762mm)	24" (610mm)	36" (914mm)	54" (1372mm)	30" (762mm)	24" (610mm)	48" (1219mm)	66" (1676mm)				
		18" (457mm)	33" (838mm)			45" (1143mm)						
		12" (305mm)	30" (762mm)			42" (1067mm)						
		9" (229mm)	28 1/2" (724mm)			40 1/2" (1029mm)						
		6" (152mm)	27" (686mm)			39" (991mm)						
		24" (610mm)	18" (457mm)			33" (838mm)	48" (1219mm)		24" (610mm)	18" (457mm)	45" (1143mm)	60" (1524mm)
	12" (305mm)		30" (762mm)	42" (1067mm)								
	9" (229mm)		28 1/2" (724mm)	40 1/2" (1029mm)								
	6" (152mm)		27" (686mm)	39" (991mm)								
	18" (457mm)		12" (305mm)	30" (762mm)	42" (1067mm)	18" (457mm)		12" (305mm)		40" (1067mm)	54" (1372mm)	
			9" (229mm)	28 1/2" (724mm)				40 1/2" (1029mm)				
		6" (152mm)	27" (686mm)	39" (991mm)								
	12" (305mm)	9" (229mm)	28 1/2" (724mm)	36" (914mm)	12" (305mm)	9" (229mm)	40 1/2" (1029)	48" (1219mm)				
		6" (152mm)	27" (686mm)			39" (991mm)						
		9" (229mm)	6" (152mm)			27" (686mm)	33" (838mm)		9" (229mm)	6" (152mm)	39" (991mm)	45" (1143mm)

* Add suffix -V (Ventilated) or-S (solid) to catalog #
Example: 234-12TT-12-V

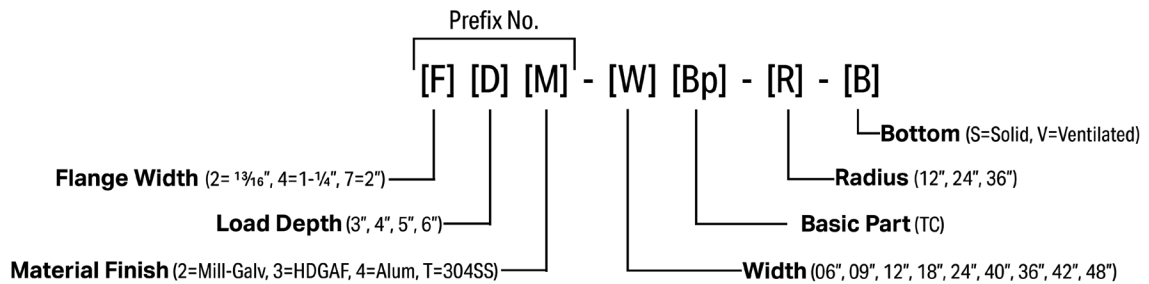


Horizontal Tapped Cross [TC]



R Radius	W Width	W1 Width	A Dim.	C Dim.
12" (305mm)	36" (914mm)	30" (762mm)	27" (686mm)	60" (1524mm)
		24" (610mm)	24" (610mm)	
		18" (457mm)	21" (533mm)	
		12" (305mm)	18" (457mm)	
		9" (229mm)	16 1/2" (419mm)	
12" (305mm)	30" (762mm)	24" (610mm)	24" (610mm)	54" (1372mm)
		18" (457mm)	21" (533mm)	
		12" (305mm)	18" (457mm)	
		9" (229mm)	16 1/2" (419mm)	
		6" (152mm)	15" (381mm)	
12" (305mm)	24" (610mm)	18" (457mm)	21" (533mm)	48" (1219mm)
		12" (305mm)	18" (457mm)	
		9" (229mm)	16" (419mm)	
12" (305mm)	18" (457mm)	12" (305mm)	18" (457mm)	42" (1067mm)
		9" (229mm)	16 1/2" (419mm)	
		6" (152mm)	15" (381mm)	
12" (305mm)	12" (305mm)	9" (229mm)	16 1/2" (419mm)	36" (914mm)
		6" (152mm)	15" (381mm)	
9" (229mm)	9" (229mm)	6" (152mm)	15" (381mm)	33" (838mm)

* Add suffix -V (Ventilated) or -S (solid) to catalog #
Example: 234-12TC-12-V



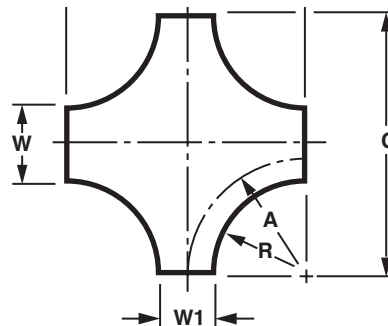
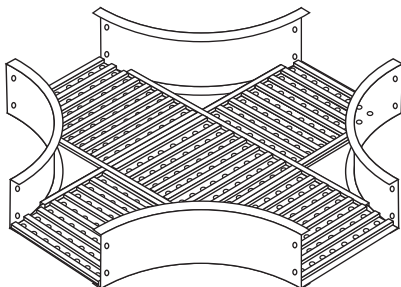
Horizontal Tapped Cross [TC] (cont.)



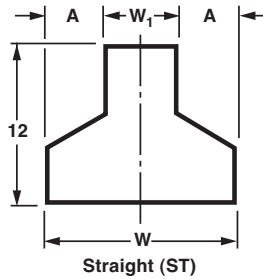
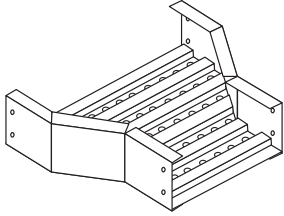
R Radius	W Width	W1 Width	A Dim.	C Dim.
24" (610mm)	36" (914mm)	30" (762mm)	39" (991mm)	84" (2134mm)
		24" (610mm)	36" (914mm)	
		18" (457mm)	33" (838mm)	
		12" (305mm)	30" (762mm)	
		9" (229mm)	28 ½" (724mm)	
	6" (152mm)	27" (686mm)		
	30" (762mm)	24" (610mm)	36" (914mm)	78" (1981mm)
		18" (457mm)	33" (838mm)	
		12" (305mm)	30" (762mm)	
		9" (229mm)	28 ½" (724mm)	
6" (152mm)		27" (686mm)		
24" (610mm)	18" (457mm)	12" (305mm)	30" (762mm)	72" (1829mm)
		9" (229mm)	28 ½" (724mm)	
		6" (152mm)	27" (686mm)	
		6" (152mm)	27" (686mm)	
18" (457mm)	9" (229mm)	12" (305mm)	30" (762mm)	66" (1676mm)
		9" (229mm)	28 ½" (724mm)	
		6" (152mm)	27" (686mm)	
12" (305mm)	9" (229mm)	6" (152mm)	28 ½" (724mm)	60" (1524mm)
		6" (152mm)	27" (686mm)	
9" (229mm)	6" (152mm)	27" (686mm)	57" (1448mm)	

R Radius	W Width	W1 Width	A Dim.	C Dim.
36" (914mm)	36" (914mm)	30" (762mm)	51" (1295mm)	108" (2743mm)
		24" (610mm)	48" (1219mm)	
		18" (457mm)	45" (1143mm)	
		12" (305mm)	42" (1067mm)	
		9" (229mm)	40 ½" (1029mm)	
	6" (152mm)	39" (991mm)		
	30" (762mm)	24" (610mm)	48" (1219mm)	102" (2591mm)
		18" (457mm)	45" (1143mm)	
		12" (305mm)	42" (1067mm)	
		9" (229mm)	40 ½" (1029mm)	
6" (152mm)		39" (991mm)		
24" (610mm)	18" (457mm)	12" (305mm)	45" (1143mm)	96" (2438mm)
		9" (229mm)	42" (1067mm)	
		9" (229mm)	40 ½" (1029mm)	
		6" (152mm)	39" (991mm)	
18" (457mm)	12" (305mm)	9" (229mm)	42" (1067mm)	90" (2286mm)
		9" (229mm)	40 ½" (1029mm)	
		6" (152mm)	39" (991mm)	
12" (305mm)	9" (229mm)	6" (152mm)	40 ½" (1029mm)	84" (2134mm)
		6" (152mm)	39" (991mm)	
9" (229mm)	6" (152mm)	39" (991mm)	81" (2057mm)	

* Add suffix -V (Ventilated) or-S (solid) to catalog #
Example: 234-12TC-12-V

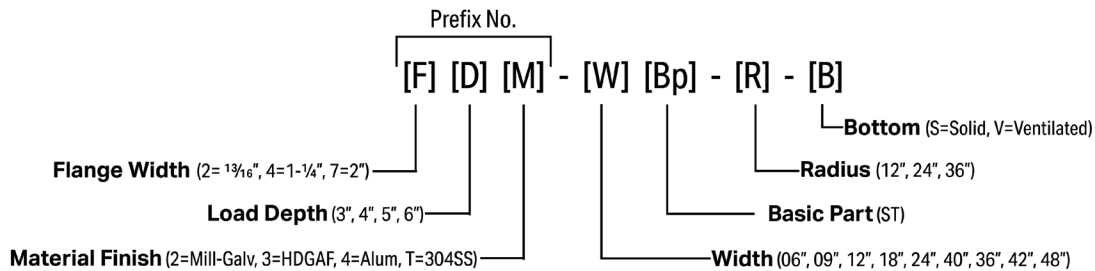


Straight Reducer [ST]



Width - W	Width - W1		A Dim.	
36" (914mm)	30"	(762mm)	3"	(76mm)
	24"	(610mm)	6"	(152mm)
	18"	(457mm)	9"	(229mm)
	12"	(305mm)	12"	(305mm)
	9"	(229mm)	13 ½"	(343mm)
	6"	(152mm)	15"	(381mm)
30" (762mm)	24"	(610mm)	3"	(76mm)
	18"	(457mm)	6"	(152mm)
	12"	(305mm)	9"	(229mm)
	9"	(229mm)	10 ½"	(267mm)
24" (610mm)	18"	(457mm)	3"	(76mm)
	12"	(305mm)	6"	(152mm)
	9"	(229mm)	7 ½"	(191mm)
	6"	(152mm)	9"	(229mm)
18" (457mm)	12"	(305mm)	3"	(76mm)
	9"	(229mm)	4 ½"	(114mm)
	6"	(152mm)	6"	(152mm)
12" (305mm)	9"	(229mm)	1 ½"	(38mm)
	6"	(152mm)	3"	(76mm)
9" (229mm)	6"	(152mm)	1 ½"	(38mm)

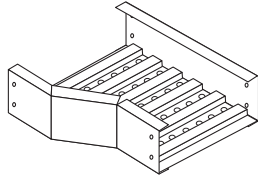
*Add suffix -V (Ventilated) or -S (solid) to catalog #
Example: 234-36ST-12-V



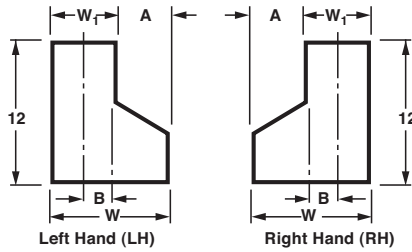
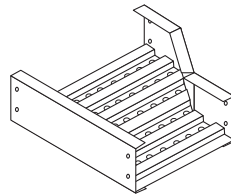
Left Hand [LH] & Right Hand [RH] Reducer



LEFT HAND (LH)

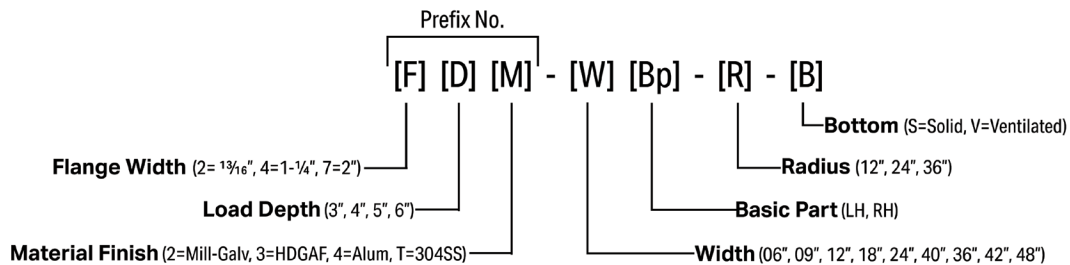


RIGHT HAND (RH)

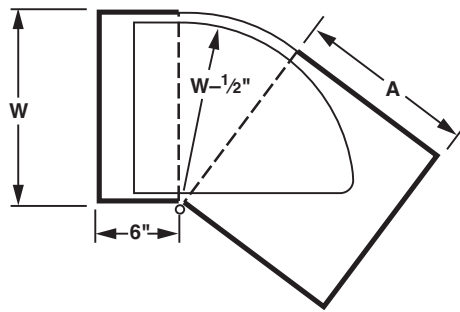
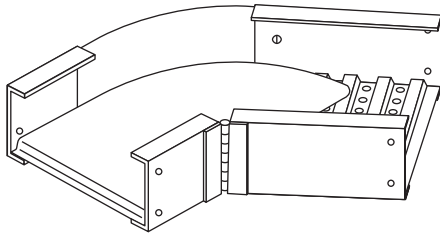


Width - W	W1 Dim.	A Dim.	B Dim.
36" (914mm)	30" (762mm)	6" (152mm)	15" (381mm)
	24" (610mm)	12" (305mm)	12" (305mm)
	18" (457mm)	18" (457mm)	9" (229mm)
	12" (305mm)	24" (610mm)	6" (152mm)
	9" (229mm)	27" (686mm)	4 1/2" (114mm)
	6" (152mm)	30" (762mm)	3" (76mm)
30" (762mm)	24" (610mm)	6" (152mm)	12" (305mm)
	18" (457mm)	12" (305mm)	9" (229mm)
	12" (305mm)	18" (457mm)	6" (152mm)
	9" (229mm)	21" (533mm)	4 1/2" (114mm)
	6" (152mm)	24" (610mm)	3" (76mm)
24" (610mm)	18" (457mm)	6" (152mm)	9" (229mm)
	12" (305mm)	12" (305mm)	6" (152mm)
	9" (229mm)	15" (381mm)	4 1/2" (114mm)
	6" (152mm)	18" (457mm)	3" (76mm)
18" (457mm)	12" (305mm)	6" (152mm)	6" (152mm)
	9" (229mm)	9" (229mm)	4 1/2" (114mm)
	6" (152mm)	12" (305mm)	3" (76mm)
12" (305mm)	9" (229mm)	3" (76mm)	4 1/2" (114mm)
	6" (152mm)	6" (152mm)	3" (76mm)
9" (229mm)	6" (152mm)	3" (76mm)	3" (76mm)

*Add suffix -V (Ventilated) or -S (solid) to catalog #
 Example: 234-36LH-12-V
 Left Hand [LH] & Right Hand [RH] Reducer



Adjustable Elbow [AF]



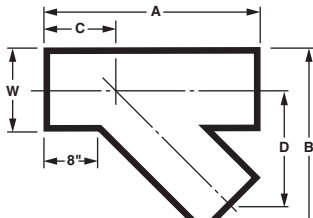
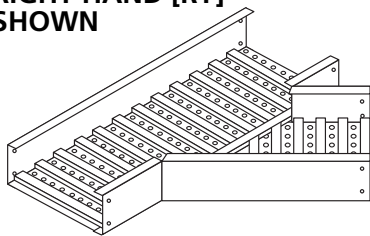
Width - W		A Dimension	
6"	(152mm)	8"	(203mm)
9"	(229mm)	11"	(279mm)
12"	(305mm)	14"	(356mm)
18"	(457mm)	20"	(508mm)
24"	(610mm)	26"	(660mm)
30"	(762mm)	32"	(813mm)
36"	(914mm)	38"	(965mm)

Both rails at hinge break to be bonded if fitting is used as equipment grounding conductor.
* Add suffix-V (Ventilated) or -S (solid) to catalog #.
Example: 234-12AF-V

45° Y Branch Left [LY] & Right [RY]

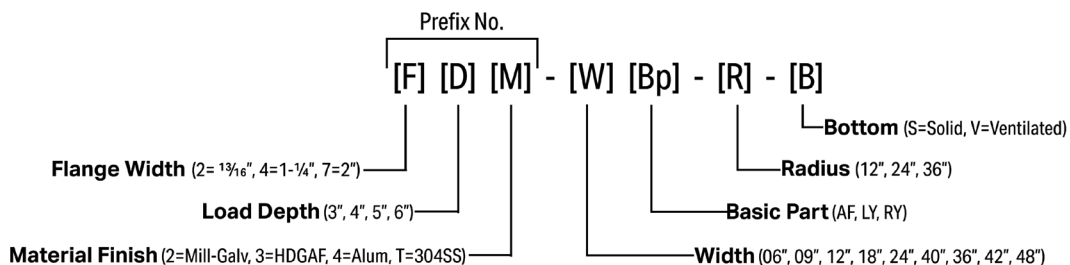


RIGHT HAND [RY]
SHOWN

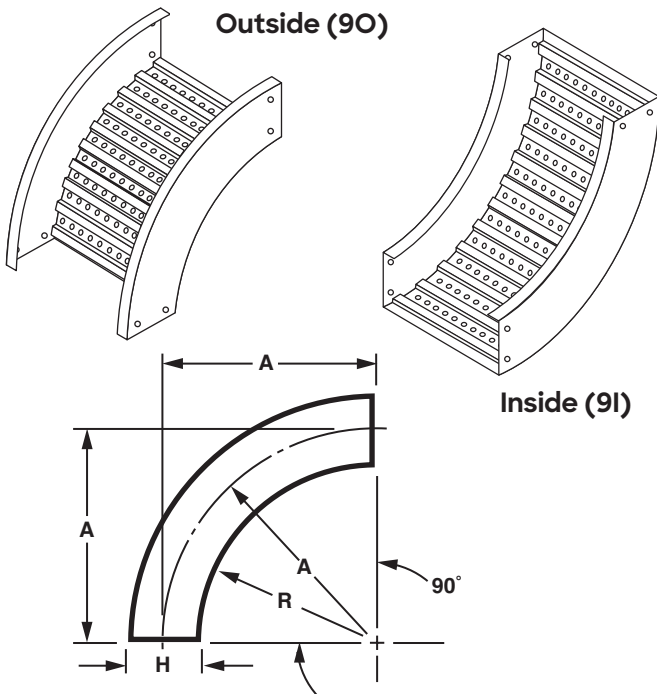


Width - W	A Dim.	B Dim.	C Dim.	D Dim.
6" (152mm)	22 1/2" (571mm)	16 1/4" (413mm)	11 3/8" (289mm)	11 1/8" (283mm)
9" (229mm)	26 3/4" (679mm)	21 3/8" (543mm)	13" (330mm)	13 3/4" (349mm)
12" (305mm)	31" (787mm)	26 1/2" (673mm)	14 3/4" (375mm)	16 1/4" (412mm)
18" (457mm)	39 1/2" (1003mm)	36 3/4" (933mm)	18 1/8" (460mm)	21 3/8" (543mm)
24" (610mm)	48" (1219mm)	47" (1193mm)	21 1/2" (546mm)	26 1/2" (673mm)
30" (762mm)	56 3/8" (1432mm)	57 1/4" (1454mm)	24 3/4" (629mm)	31 5/8" (803mm)
36" (914mm)	65" (1651mm)	67 1/2" (1714mm)	28 1/4" (718mm)	36 3/4" (933mm)

*Add suffix -V (Ventilated) or -S (solid) to catalog #.
Example: 234-12RY-V



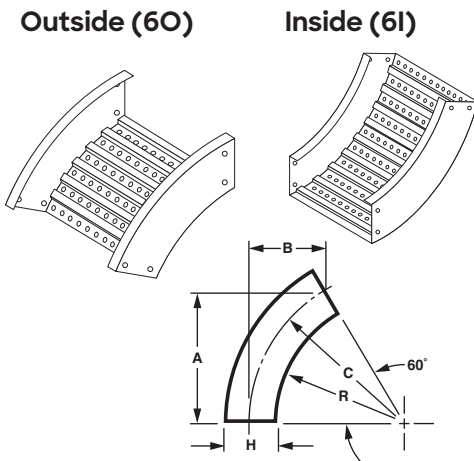
90° Vertical Elbow Outside [90] & Inside [9I]



Radius - R	H Dim.	A Dim.
12 (305mm)	3 1/2 (89mm)	13 3/4 (349mm)
	4 1/4 (108mm)	14 1/8 (359mm)
	5 1/4 (133mm)	14 5/8 (372mm)
	6 1/4 (159mm)	15 1/8 (384mm)
24 (610mm)	3 1/2 (89mm)	25 3/4 (654mm)
	4 1/4 (108mm)	26 1/8 (664mm)
	5 1/4 (133mm)	26 5/8 (676mm)
	6 1/4 (159mm)	27 1/8 (689mm)
36 (914mm)	3 1/2 (89mm)	37 3/4 (959mm)
	4 1/4 (108mm)	36 1/8 (969mm)
	5 1/4 (133mm)	36 5/8 (981mm)
	6 1/4 (159mm)	39 1/8 (994mm)

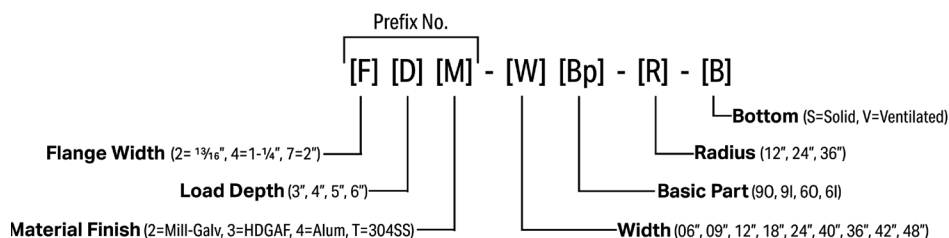
*Add suffix -V (Ventilated) or -S (solid) to catalog #.
Example: 234-1290-12-V

60° Vertical Elbow Outside [60] & Inside [6I]



Radius - R	H Dim.	A Dim.	B Dim.	C Dim.
12" (305mm)	3 1/2" (89mm)	11 7/8" (302mm)	6 7/8" (175mm)	13 3/4" (349mm)
	4 1/4" (108mm)	12 1/4" (311mm)	7 1/8" (181mm)	14 1/8" (359mm)
	5 1/4" (133mm)	12 5/8" (321mm)	7 3/8" (187mm)	14 5/8" (372mm)
	6 1/4" (159mm)	13 1/8" (334mm)	7 5/8" (194mm)	15 1/8" (384mm)
24" (610mm)	3 1/2" (89mm)	22 1/4" (565mm)	12 7/8" (327mm)	25 3/4" (654mm)
	4 1/4" (108mm)	22 5/8" (575mm)	13 1/8" (334mm)	26 1/8" (664mm)
	5 1/4" (133mm)	23 1/8" (588mm)	13 3/8" (340mm)	26 5/8" (676mm)
	6 1/4" (159mm)	23 1/2" (597mm)	13" (330mm)	27 1/8" (689mm)
36" (914mm)	3 1/2" (89mm)	32 3/4" (832mm)	18 7/8" (480mm)	37 3/4" (959mm)
	4 1/4" (108mm)	33" (838mm)	19 1/8" (486mm)	38 1/8" (969mm)
	5 1/4" (133mm)	33 1/2" (851mm)	19 3/8" (492mm)	38 5/8" (981mm)
	6 1/4" (159mm)	33 3/8" (861mm)	19 5/8" (499mm)	39 1/8" (994mm)

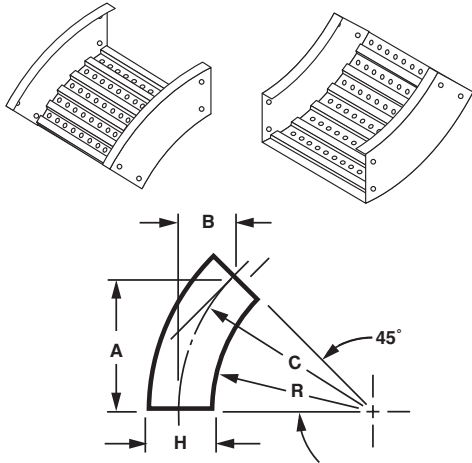
*Add suffix -V (Ventilated) or -S (solid) to catalog #.
Example: 234-1260-12-V



45° Vertical Elbow Outside [4O] & Inside [4I]

Outside (4O)

Inside (4I)



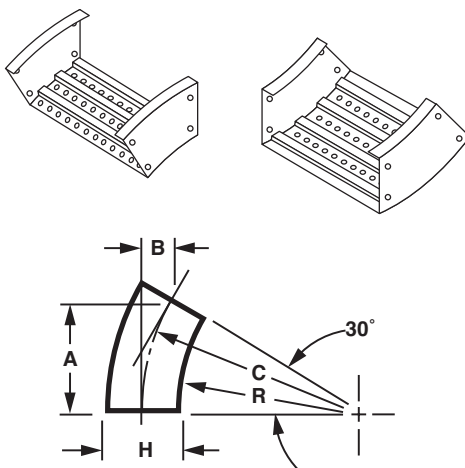
Radius - R	H Dim.	A Dim.	B Dim.	C Dim.
12" (305mm)	3 1/2" (89mm)	9 3/4" (248mm)	4" (102mm)	13 3/4" (349mm)
	4 1/4" (108mm)	10" (254mm)	4 1/8" (105mm)	14 1/8" (359mm)
	5 1/4" (133mm)	10 3/8" (264mm)	4 1/4" (108mm)	14 5/8" (372mm)
	6 1/4" (159mm)	10 3/4" (273mm)	4 1/2" (114mm)	15 1/8" (384mm)
24" (610mm)	3 1/2" (89mm)	18 1/4" (464mm)	7 1/2" (191mm)	25 3/4" (654mm)
	4 1/4" (108mm)	18 1/2" (470mm)	7 5/8" (194mm)	26 1/8" (664mm)
	5 1/4" (133mm)	18 7/8" (480mm)	7 7/8" (200mm)	26 5/8" (676mm)
	6 1/4" (159mm)	19 1/4" (489mm)	8" (203mm)	27 1/8" (689mm)
36" (914mm)	3 1/2" (89mm)	26 3/4" (679mm)	11 1/8" (283mm)	37 3/4" (959mm)
	4 1/4" (108mm)	27" (686mm)	11 1/8" (283mm)	38 1/8" (969mm)
	5 1/4" (133mm)	27 3/8" (695mm)	11 3/8" (289mm)	38 5/8" (981mm)
	6 1/4" (159mm)	27 5/8" (702mm)	11 1/2" (292mm)	39 1/8" (994mm)

*Add suffix -V (Ventilated) or -S (solid) to catalog #
Example: 234-124I-12-V

30° Vertical Elbow Outside [3O] & Inside [3I]

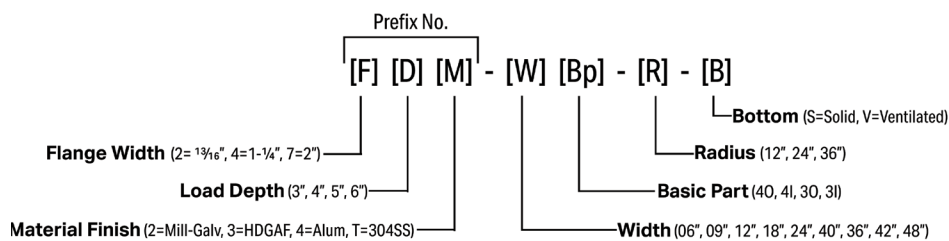
Outside (3O)

Inside (3I)



Radius - R	H Dim.	A Dim.	B Dim.	C Dim.
12" (305mm)	3 1/2" (89mm)	6 7/8" (175mm)	1 7/8" (48mm)	13 3/4" (349mm)
	4 1/4" (108mm)	7 1/8" (181mm)	1 7/8" (48mm)	14 1/8" (359mm)
	5 1/4" (133mm)	7 3/8" (187mm)	2" (51mm)	14 5/8" (372mm)
	6 1/4" (159mm)	7 5/8" (194mm)	2" (51mm)	15 1/8" (384mm)
24" (610mm)	3 1/2" (89mm)	12 7/8" (327mm)	3 1/2" (89mm)	25 3/4" (654mm)
	4 1/4" (108mm)	13 1/8" (334mm)	3 1/2" (89mm)	26 1/8" (664mm)
	5 1/4" (133mm)	13 3/8" (340mm)	3 5/8" (92mm)	26 5/8" (676mm)
	6 1/4" (159mm)	13 5/8" (346mm)	3 5/8" (92mm)	27 1/8" (689mm)
36" (914mm)	3 1/2" (89mm)	18 7/8" (480mm)	5 1/8" (130mm)	37 3/4" (959mm)
	4 1/4" (108mm)	19 3/8" (486mm)	5 1/8" (130mm)	38 1/8" (969mm)
	5 1/4" (133mm)	19 3/8" (492mm)	5 1/4" (133mm)	38 5/8" (981mm)
	6 1/4" (159mm)	19 5/8" (499mm)	5 1/4" (133mm)	39 1/8" (994mm)

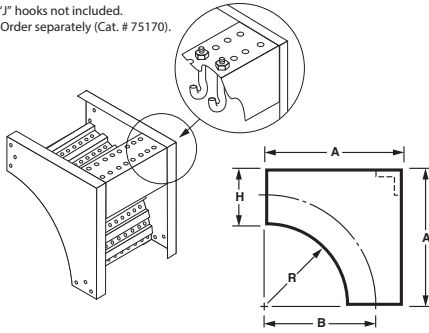
*Add suffix -V (Ventilated) or -S (solid) to catalog #
Example: 234-123I-12-V



90° Vertical Cable Support Elbow [SR]



*J" hooks not included.
Order separately (Cat. # 75170).



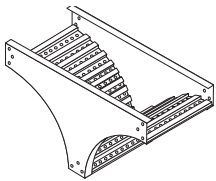
Radius-R	H Dim.	A Dimension	B Dimension
12" (305mm)	3 1/2" (89mm)	15 1/2" (394mm)	13 3/4" (349mm)
	4 1/2" (108mm)	16 1/4" (413mm)	14 1/8" (359mm)
	5 1/4" (133mm)	17 1/4" (438mm)	14 5/8" (371mm)
	6 1/4" (159mm)	18 1/4" (464mm)	15 1/8" (384mm)
24" (610mm)	3 1/2" (89mm)	27 1/2" (699mm)	25 3/4" (654mm)
	4 1/4" (108mm)	28 1/4" (718mm)	26 1/8" (664mm)
	5 1/4" (133mm)	29 1/4" (743mm)	26 5/8" (676mm)
36" (914mm)	3 1/2" (89mm)	39 1/2" (1003mm)	37 3/4" (959mm)
	4 1/4" (108mm)	40 1/4" (1022mm)	38 1/8" (968mm)
	5 1/4" (133mm)	41 1/4" (1048mm)	38 5/8" (981mm)
	6 1/4" (159mm)	42 1/4" (1073mm)	39 1/8" (994mm)

*Add suffix -V (Ventilated) or -S (solid) to catalog #
Example: 234-12SR-12-V

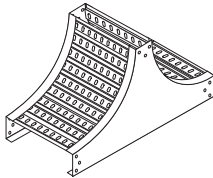
Vertical Tee Down [VT] & Up [OT]



Vertical Tee - Down (VT)

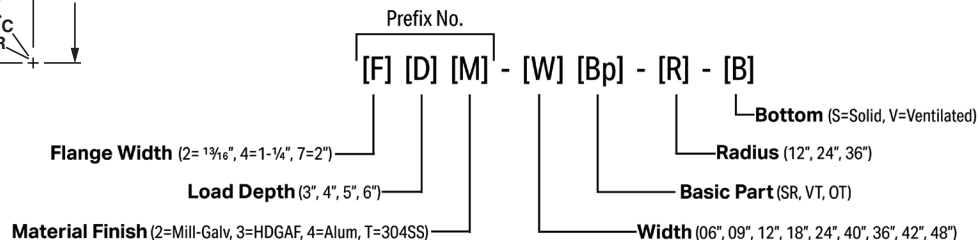
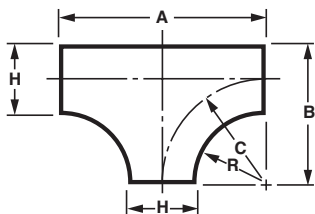


Vertical Tee - Up (OT)



Radius-R	H Dim.	A Dimension	B Dimension	C Dimension
12" (305mm)	3 1/2" (89mm)	27 1/2" (699mm)	15 1/2" (394mm)	13 3/4" (349mm)
	4 1/4" (108mm)	28 1/4" (718mm)	16 1/4" (413mm)	14 1/8" (359mm)
	5 1/4" (133mm)	29 1/4" (743mm)	17 1/4" (438mm)	14 5/8" (371mm)
	6 1/4" (159mm)	30 1/4" (768mm)	18 1/4" (464mm)	15 1/8" (384mm)
24" (610mm)	3 1/2" (89mm)	51 1/2" (1308mm)	27 1/2" (699mm)	25 3/4" (654mm)
	4 1/4" (108mm)	52 1/4" (1327mm)	28 1/4" (718mm)	26 1/8" (664mm)
	5 1/4" (133mm)	53 1/4" (1353mm)	29 1/4" (743mm)	26 5/8" (676mm)
36" (914mm)	3 1/2" (89mm)	75 1/2" (1918mm)	39 1/2" (1003mm)	37 3/4" (959mm)
	4 1/4" (108mm)	76 1/4" (1937mm)	40 1/4" (1022mm)	38 1/8" (968mm)
	5 1/4" (133mm)	77 1/4" (1962mm)	41 1/4" (1048mm)	38 5/8" (981mm)
	6 1/4" (159mm)	78 1/4" (1988mm)	42 1/4" (1073mm)	39 1/8" (994mm)

*Add suffix -V (Ventilated) or -S (solid) to catalog #
Example: 234-12VT-12-V



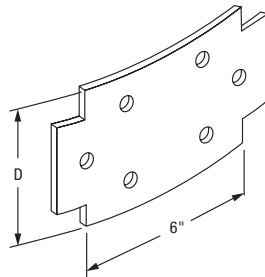
Connector Plates

Connector Plates (splice plates) are made of 11 Gauge Steel and are furnished with $\frac{3}{8}$ "-16 spline bolts & flange nuts unless otherwise specified. Hole patterns match corresponding tray. Three-hole pattern illustrated.

Add -SS for 304 Stainless Steel Hardware and -S1 for 316 Stainless Steel Hardware. Standard hardware is EG. *HDGAF connector plates are used with Mill-Galv and HDGAF Systems. Mill-Galv connector plates are not available.

Universal Curvilinear Connector [RC]

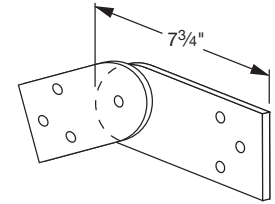
Load Depth	Finish	Basic No.
3" = 3	3 (HDGAF)* 4 (Alum) U (304SS)	-02RC
4" = 3	7 (HDGAF)*	
5" = 4	8 (Alum)	
6" = 5	T (304SS)	



Example: 48-02RC for 3" load depth, Alum, universal curvilinear connector
Note: Sold in pairs.

Vertical Adjustable Connector [CV]

Load Depth	Finish	Basic No.
3" = 3	3 (HDGAF)* 4 (Alum) U (304SS)	-02CV
4" / 5" = 3	7 (HDGAF)*	
6" = 5	8 (Alum) T (304SS)	

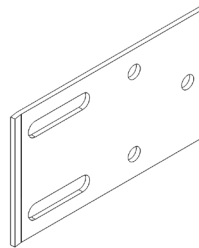


Example: 48-02CV for 3" load depth, alum, vertical adjustable connector
Note: Sold in pairs.. Bonding jumpers required and are sold separately.

Expansion Connector [CE]

- $\frac{3}{8}$ "-16 cap screws & Nylok nuts furnished and $\frac{3}{8}$ "-16 spline bolts & flange nuts furnished

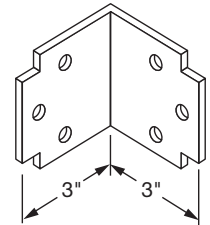
Load Depth	Finish	Basic No.
3" = 3	3 (HDGAF)* 4 (Alum) U (304SS)	-02CE
4" = 3	7 (HDGAF)*	
5" = 4	8 (Alum)	
6" = 5	T (304SS)	



Example: 48-02CE for 3" load depth, alum, expansion connector
Note: Sold in pairs.. Bonding jumpers required and are sold separately.

90° Angle Connector [CA]

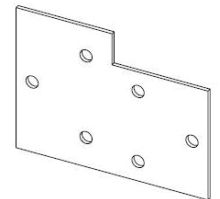
Load Depth	Finish	Basic No.
3" = 3	3 (HDGAF)* 4 (Alum) U (304SS)	-02CA
4" = 3	7 (HDGAF)*	
5" = 4	8 (Alum)	
6" = 5	T (304SS)	



Example: 48-02CA for 3" load depth, alum, 90° Angle Connector
Note: Sold in pairs..

Stepdown Connector [CD]

- Used to change from one load depth to another

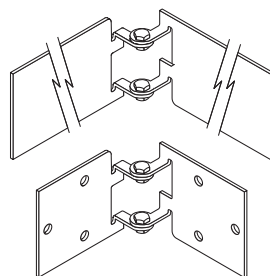


Load Depth	Finish	Basic No.	Load Depth 2	Finish 2
5" = 4	7 (HDGAF)*	-02CD	4" = 3	7 (HDGAF)*
6" = 5	8 (Alum)		5" = 4	8 (Alum)
	T (304SS)			T (304SS)

Example: 48-02CD-38 for 4" to 3" load depth, alum, stepdown connector
Note: Sold in pairs.. 4" to 3" trof stepdown connector available upon request

Horizontal Adjustable Connector [CH]

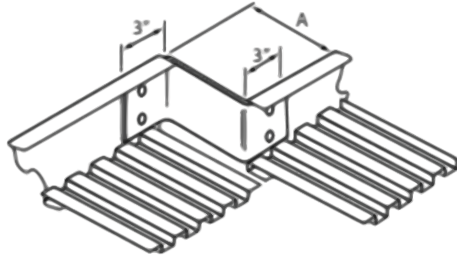
Load Depth	Finish	Basic No.
3" = 3	3 (HDGAF)* 4 (Alum) U (304SS)	-02CH
4" = 3	7 (HDGAF)*	
5" = 4	8 (Alum)	
6" = 5	T (304SS)	



Example: 48-02CH for 3" load depth, alum, horizontal adjustable connector
Note: Sold in pairs.. Bonding jumpers required and are sold separately.

Reducing Connectors [CO]

Note: Sold in pairs.



Catalog

Load Depth	Finish	Basic No.	A Dimension	
3" = 3	3 (HDGAF)*	-30CO	30"	(762mm)
	4 (Alum)	-27CO	27"	(686mm)
	U (304SS)	-24CO	24"	(610mm)
4" = 3	7 (HDGAF)*	-21CO	21"	(533mm)
5" = 4	8 (Alum)	-18CO	18"	(457mm)
6" = 5	T (304SS)	-15CO	15"	(381mm)
		-13CO	13 1/2"	(343mm)
		-12CO	12"	(305mm)
		-10CO	10 1/2"	(267mm)
		-09CO	9"	(229mm)
		-07CO	7 1/2"	(191mm)
		-06CO	6"	(152mm)
		-04CO	4 1/2"	(114mm)
		-03CO	3"	(76mm)
		-01CO	1 1/2"	(38mm)

Example: 48-02CO for 3" load depth, alum, 3" reducer connector. Typical use: 9" to 6", or use 2 for 12" to 6", etc.

Hardware

Material/Finish

Electro-galvanized finish standard. Other finishes available; consult factory.

*Use following suffix when applicable - use only where indicated.

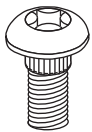
- No Suffix - Electro-galvanized carbon steel only
- SS Suffix - 304 Stainless Steel
- S1 Suffix - 316 Stainless Steel (check factory for availability)
- Example: 5003-1-SS, 3/8"-16 x 1" spline bolt, 304 stainless steel

Connector Hardware Bolt [5003], Nut [5009]

- Case-hardened steel electro-galvanized

Catalog # 5003-1

3/8"-16 x 1" spline bolt



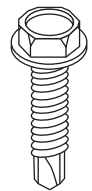
Catalog # 5009-1

3/8"-16 hex-flanged nut with serrated washer face.



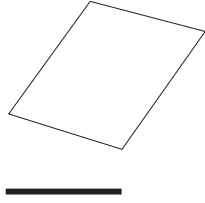
Cover Screws [EM]

- Catalog # EM-CC (electro-galv. steel)
Catalog # EM-CC-SS (stainless steel)
- No. 10 x 5/8" long, self drilling-self tapping hex head plated steel screw
- Suggested spacing:
Indoor: 8 per 12'

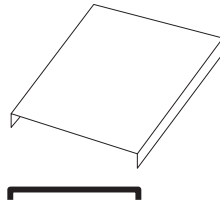


Covers

Covers for straight sections shown. Standard fitting covers are flanged solid type (FS). Aluminum covers are fabricated from 0.040 aluminum AA-3150-H14; steel covers are fabricated from 20 Gauge ASTM A-653-G90 CQ, mill-galvanized steel.



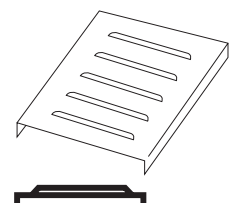
NF - Flat Solid



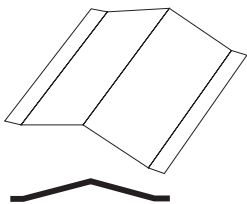
FS - Flanged Solid
w/ 3/8" Flange



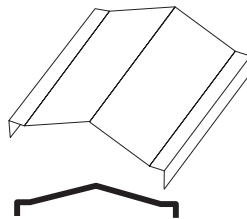
NL - Flat Louvered



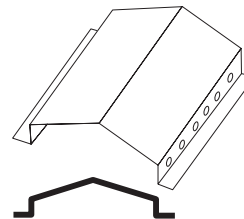
FL - Flanged Louvered
w/ 3/8" Flange



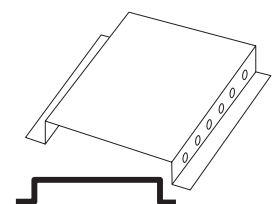
PS - Peaked Solid
(suffix height)



PF - Peaked Flanged
Solid w/ 3/8" Flange
(suffix height)



PH - Peaked Hat Solid
PV - Peaked Hat Vent
(suffix height)



HS - Hat Solid
HV - Hat Vent
(suffix height)

Cover Catalog # - Straight Sections

Type	Finish	Basic No. (Width)	Length	Height**
NF, FS	2 - Mill-Galv.	-06SL = 6" (152mm)	-12'	-2"
NL, FL	3 - HDGAF	-09SL = 9" (229mm)	-10'	
PS, PF	4 - Alum.	-12SL = 12" (305mm)	-06'	
PV, PH	U - 304SS	-18SL = 18" (457mm)		
HS, HV		-24SL = 24" (610mm)		
		-30SL = 30" (762mm)		
		-36SL = 36" (914mm)		

*NF, NL, and PS covers are not available in HDGAF

**Peak and hat only, 2" height standard. Consult factory for other heights.

Example: NL2-09SL-12 is a flat louvered mill-galvanized steel cover for a 9" wide mill-galvanized TROF 12' long.

Cover Catalog # - Fittings

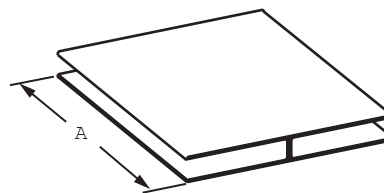
Type	Load Depth*	Finish	Width/Basic No.	Radius
NF	3"	2 - Mill-Galv.	-06 XX**	12"
FS	4"	3 - HDGAF	-09 XX**	24"
NL	5"	4 - Alum.	-12 XX**	36"
FL	6"	U - 304SS	-18 XX**	
			-24 XX**	
			-30 XX**	
			-36 XX**	

*Load depth for outside riser or vertical tee only.

**XX from fitting selection page 97-110.

Joint Plate

- Joint plate is black PVC and is offered in 10' lengths to be field cut to desired length, or in precut lengths for specified covers
- JP-120 is joint plate in 10' lengths
- Joint plate for specified covers is specified as follows

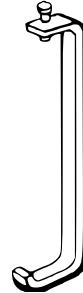


Catalog #	Tray Size
JP-06	6" (152mm)
JP-09	9" (229mm)
JP-12	12" (305mm)
JP-18	18" (457mm)
JP-24	24" (610mm)
JP-30	30" (762mm)
JP-36	36" (914mm)
JP-120	10' for field cut

Cover Accessories

Single Side Connector [01CC]

- Furnished with ¼"-28 stainless steel cone point machine screw
- For use with any width tray
- Not sold in pairs
- Suggested spacing:
Indoor Use Only;
4 per 12' section



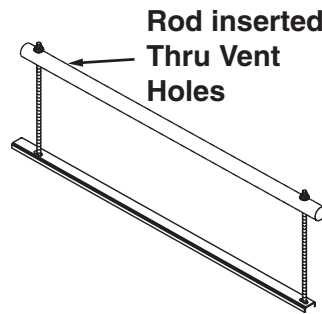
Catalog # [Basic No -01CC]

Flange (in)	Load Depth	Finish
2 - 1 ³ / ₁₆	3"	2 - Mill-Galv.
4 - 1 1/4	4"	3 - HDGAF
5 - 1 1/2	5"	4 - Alum.
7 - 2	6"	U - 304SS

Example: 234-01CC for 3" load depth, aluminum single side connector.

Peak Vent Cover Connector [VC]

Note: For PV & HV Covers



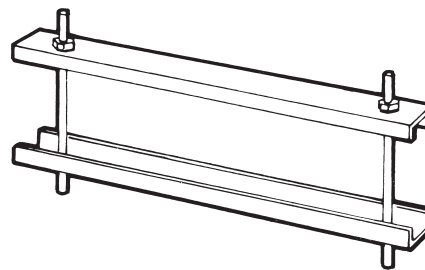
Catalog

Flange (in)	Load Depth	Finish	Width	Type
2 = 1 ³ / ₁₆	3"	2=Mill-Galv.	-06	VC
4 = 1 1/4	4"	3=HDGAF	-09	
5 = 1 1/2	5"	4=Alum.	-12	
6 = 1 3/4	6"	U=304SS	-18	
7 = 2			-24	
			-30	
			-36	

Example: 238-12VC for 3" load depth, 1³/₁₆" flange, aluminum, 12" wide, Peak Ventilated Cover Connector

Double Clamp Connector [DC]

- Furnished with:
(2) ¼"-20 all-thread rods
(4) hex nuts, flat washers and lock washers
- Suggested spacing:
Indoor: 2 per 12'
Outdoor: 3 per 12'
High Wind: 5 per 12'



Note: For all covers except hat & peak type.

Catalog

Load Depth	Finish	Width	Type
3"	2 - Mill-Galv.	-06	DC
4"	3 - HDGAF	-09	
5"	4 - Alum.	-12	
6"	U - 304SS	-18	
		-24	
		-30	
		-36	

Example: 34-12DC for 3" load depth, 1³/₁₆" flange, aluminum, 12" wide, Double Clamp Connector.

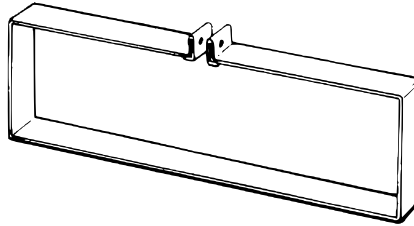


Cover Accessories

Cover Connector [CC]

- IB and OB fitting hardware available in EG and SS only
- Suggested spacing:
 - Indoor: 2 per 12'
 - Outdoor: 3 per 12'
 - High Wind: 5 per 12'

Note: For all covers except hat & peak type



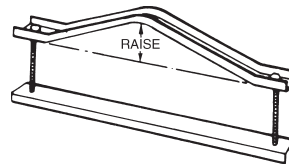
Catalog

Load Depth	Finish	Width	Type
3	2 - Mill-Galv.	-06	CC
4	3 - HDGAF	-09	
5	4 - Alum.	-12	
6	U - 304SS	-18	
		-24	
		-30	
		-36	

Example: 34-12CC for 3" load depth, 1/8" flange, aluminum, 12" wide connector.

Peak Cover Connector [PC]

Note: For PS & PF Cover



Catalog

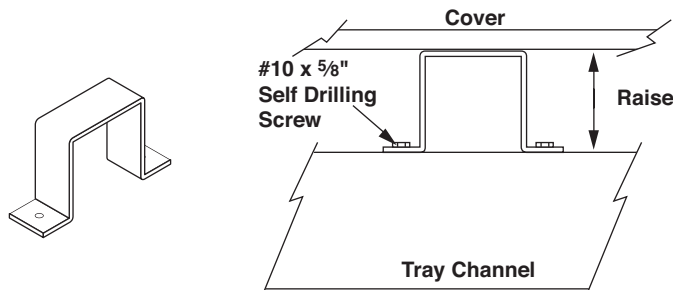
Load Depth	Finish	Width	Type	Raise (in)*
3	2 - Mill-Galv.	-06	PC	-2
4	3 - HDGAF	-09		
5	4 - Alum.	-12		
6	U - 304SS	-18		
		-24		
		-30		
		-36		

*2 standard raise. Consult factory for other peak heights.

Example: 34-12PC-2 for 3" load depth, aluminum, 12" wide, Peak Cover Connector (Ventilated cover) with 2" peak.

Elevated Cover Connector [EM-CC]

- Includes: (3) #10 x 5/8" Self drilling screws
- Suggested spacing:
 - Indoor: 3/Side (6 tot.) per 12'



Catalog

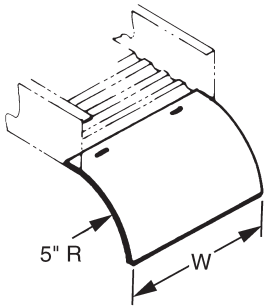
Finish	Type	Raise*
2 - Mill-Galv.	EM-CC	- 1
3 - HDGAF		- 2
4 - Alum.		- 3
U - 304SS		

Example: 3-EM-CC-2 for hot dipped galvanized, Elevated Cover Connector with a 2" raise.

Accessories

Drop Out [DO]

- 14 Gauge Steel, .080 Aluminum



Catalog

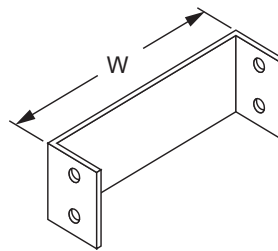
Basic Finish	Width
2 (Mill-Galv.)	-06DO = 6" (152mm)
3 (HDGAF)	-09DO = 9" (229mm)
4 (Alum.)	-12DO = 12" (305mm)
U (304SS)	-18DO = 18" (457mm)
	-24DO = 24" (610mm)
	-30DO = 30" (762mm)
	-36DO = 36" (914mm)

Example: 4-12DO for aluminum, 12" wide, Drop Out.

Blind End [BE]

- 22 Gauge Steel, .040 Aluminum

Note: $\frac{3}{8}$ " -16 spline bolts and flange nuts furnished



Catalog

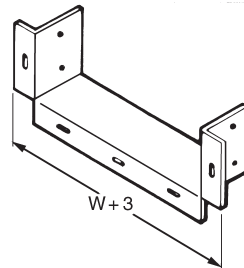
Load Depth	Finish	Width
3"	2 (Mill-Galv.)	-06BE = 6" (152mm)
4"	3 (HDGAF)	-09BE = 9" (229mm)
5"	4 (Alum.)	-12BE = 12" (305mm)
6"	U (304SS)	-18BE = 18" (457mm)
		-24BE = 24" (610mm)
		-30BE = 30" (762mm)
		-36BE = 36" (914mm)

Example: 34-12BE for 3" load depth, aluminum, 12" wide Blind End.

Box Connector [CB]

- 14 Gauge Steel .080 Aluminum

Note: $\frac{1}{4}$ " -20 carriage bolts, flat washers, hex nuts furnished



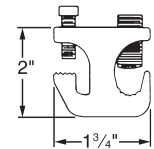
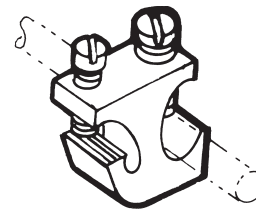
Catalog

Load Depth	Finish	Width
3"	2 - (Mill-Galv.)	-06CB = 6" (152mm)
4"	3 - (HDGAF)	-09CB = 9" (229mm)
5"	4 - (Alum.)	-12CB = 12" (305mm)
6"	U - (304SS)	-18CB = 18" (457mm)
		-24CB = 24" (610mm)
		-30CB = 30" (762mm)
		-36CB = 36" (914mm)

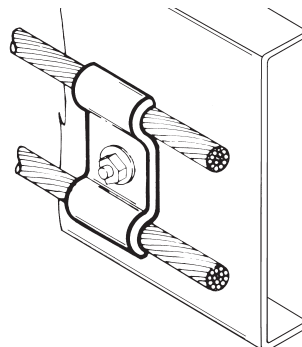
Example: 34-12CB for 3" load depth, aluminum, 12" wide, Box Connector.

Cable Tray Ground Clamp [9156]

- Extruded Alum. with Electro-Galvanized Steel Hex Head Screws
- Capacity: #6 AWG to 250 kcmil
- UL Listed and CSA Certified for grounding



Ground Cable Retainer Clamp



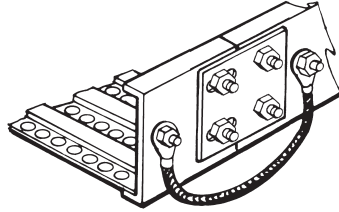
Catalog #	Capacity	Metal & Finish	Dimensions
9056-EP	1/2, 3/4, 1"	Electro-Galv. Steel	1" w x 2" long
9057-EP	1/2, 3/4, 1"	Electro-Galv. Steel	1" w x 2 3/8" long
9056-SS	1/2, 3/4, 1"	Stainless Steel	1" w x 2" long
9057-SS	1/2, 3/4, 1"	Stainless Steel	1" w x 2 3/8" long

Accessories

Bonding Jumper [CBJ]

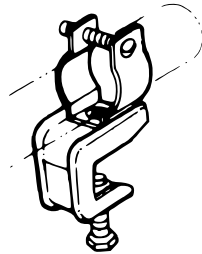
- For hardware kit add -HDW
- Ex: CBJ-C-HDW
 - 2ea CBJ-C
 - 4ea 5003-1
 - 4ea 5009-1

Note: No hardware supplied



Catalog #	Dimensional Data	Amperes as Equipment Ground
CBJ-C	AWG# copper wire 15 1/2 long overall	800 amperes
CBJ-4C	AWG# copper wire 15 1/2 long overall	1,600 amperes
CBJ-250C	250 MCM copper wire 15 1/2 long overall	2,000 amperes

Conduit Clamp Brackets

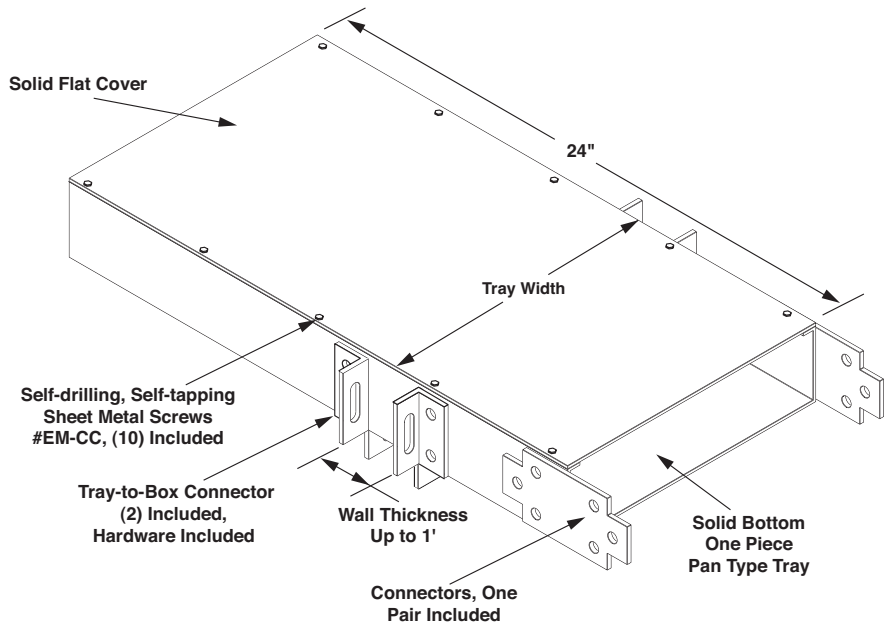


Catalog #	Size Rigid	Size EMT
CCB-050	3/8" to 1/2"	1/2"
CCB-075	3/4"	3/4"
CCB-100	1"	1"
CCB-125	-	1 1/4"
CCB-150	1 1/4"	1 1/2"
CCB-200	2"	2"

Wall Penetrating Sleeve Assembly [SS89042W*]

- W = Tray Width
- * = Fitting 3-Digit Prefix

Note: Standard penetration sleeves are manufactured from mill-galvanized steel
Aluminum sleeves are available upon request



Barrier Strips

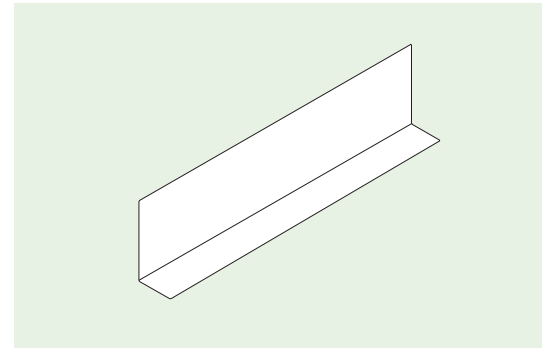
Universal Aluminum Barrier Strip - Straight Section [SB]

- Furnished with (8) self tapping screws

Catalog

Load Depth	Finish	Basic No.	Length
3"	A (Alum.)	-01SB	12'
4"			
5"			
6"			

Example: 3A-01SB-12 for 3" load depth, aluminum straight barrier, 12' long.



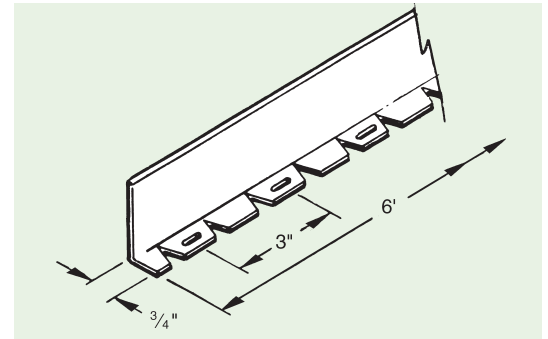
Barrier Strip - Horizontal Fitting [FB]

- Furnished with 4 self tapping screws.

Catalog

Load Depth	Finish	Basic No.	Length
3"	2 (Mill-Galv.)	-01FB	06'
4"	3 (HDGAF)		
5"	4 (Alum.)		
6"	U (304 SS)		

Example: 34-01FB-06 for 3" load depth, aluminum fitting barrier, 6' long.



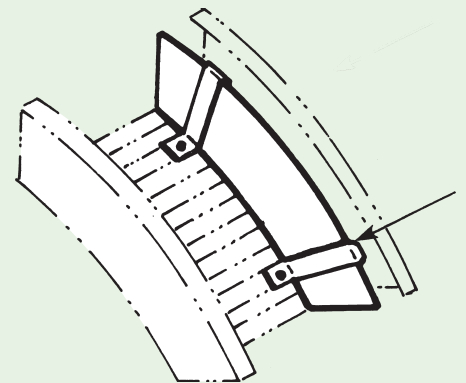
Barrier Strip Vertical Elbow Outside [OB] & Inside [IB]

- Furnished with sufficient clamp assemblies for installation
- Additional clamp assemblies may be ordered separately
- IB and OB fitting hardware available in EG and SS only

Catalog

Load Depth	Finish	Bend (deg.)	Basic No.	Radius
3"	2 (Mill-Galv.)	90°	OB = Outside	12" (305mm)
4"	3 (HDGAF)	60°	IB = Inside	24" (610mm)
5"	4 (Alum.)	45°		36" (914mm)
6"	U (304 SS)	30°		

Example: 34-900B-12 for 3" load depth, aluminum 90° outside vertical barrier with 12" radius.



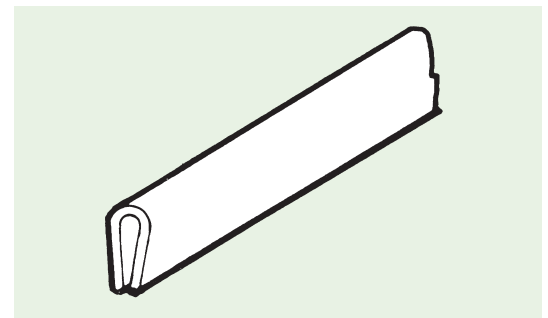
Note: OB Vert. Elbow outside shown

Nylon Carrier Splice & Protector [BSP-L]

Catalog

Prefix	Length (L)
BSP	-5 (5' Splice) -144 (144" Protector) -1200 (100' Roll)

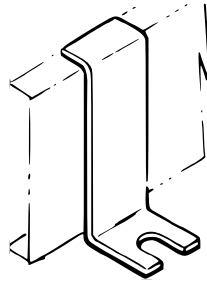
Example: BSP-1200 for 100' roll



Accessories

Hold-Down Clamp & Expansion Guide

- For expansion guide clamp, add suffix EX to catalog #
- Complete Kit add -HDW to Part No. Above
 - Hardware Kit List:
 - (2) Hold-Down Clamps
 - (2) ½" - 13 x 1¼" Cap Screw
 - (2) ½" Flat Washer
 - (2) Clamping Nut (Strut Nut)



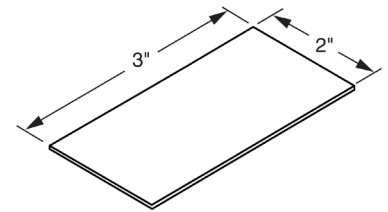
Catalog

Load Depth	Basic No.	Materials
3"	-9039	Aluminum
4"	-9040	Electro-galv. Steel
5"	-9041	HDGAF
6"	-9042	316SS

Example: 3-9039-EX for 3" load depth, expansion guide. Hardware purchased separately to suit support system.

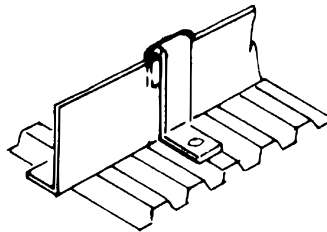
Isolation Pad [PVC-PAD]

- For use with the 9039 series of Hold-Down Clamp & Expansion Guide
- The Isolation pad provides protection from galvanic corrosion when Aluminum tray is mounted on steel supports
- Hardware purchased separately



Barrier Strip Clamp [50172] (Optional)

- No. 10 bolt, nut, washer and lock washer furnished



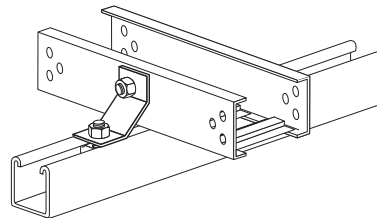
Catalog

Load Depth	Finish	Basic Number
3"	2 (Mill-Galv.)	-50172
4"	3 (HDGAF)	
5"	4 (Alum.)	
6"	U (304 SS)	

Example: 34-50172 for 3" load depth, aluminum clamp.

Seismic Hold-Down [9132]

- For seismic applications or other bolted connections is preferred
- 4" wide and 4" tall and made from 11 Gauge material



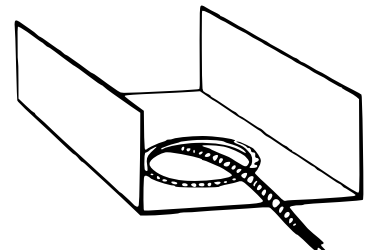
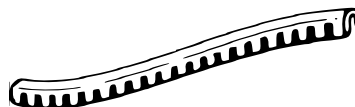
Catalog

Catalog #	Material
9132	Mill-Galvanized
9133	Stainless Steel

Hardware purchased separately to suit support system.

Nylon Dropout Grommet [DOG-1]

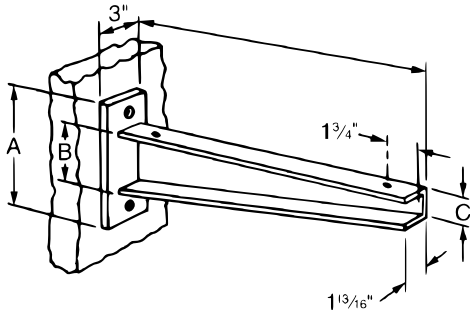
- Use at cable dropouts, or thru vent holes
- Furnished in 12' lengths. Cut to length in field



Support Brackets

Wall Support Bracket

- Finish is hot-dip galvanized after fabrication
- Order hardware separately

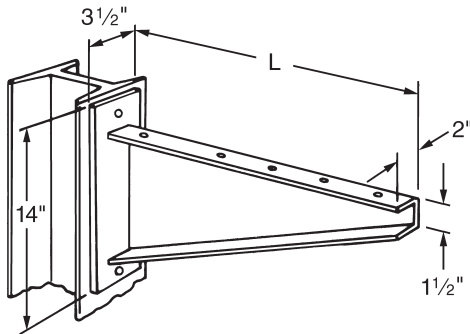


Catalog #	Trof Width	Length L	Dimensions			End-Load Rating*
			A	B	C	
9037-12	6"	12 1/4"	10"	6"	2"	2000 lbs
9037-18	12"	18 1/4"	11"	7"	2 1/2"	2000 lbs
9037-24	18"	24 1/4"	11"	7"	2 1/2"	1600 lbs
9037-30	24"	30 1/4"	12"	8"	4"	1300 lbs
9037-36	30"	36 1/4"	12"	8"	4"	1100 lbs
9037-42	36"	42 1/4"	12"	8"	4"	900 lbs

*Uniform load rating is normally twice the end-load rating.

Structural Support Bracket

- For use with Cope Trof 24" or wider
- May be welded or bolted to building steel
- Finish is hot-dip galvanized after fabrication
- Order hardware separately



Catalog #	Trof Width	Length L	End-Load Rating*
9036-31	24"	31 1/4"	2000 lbs
9036-37	30"	37 1/4"	1800 lbs
9036-45	36"	45 1/4"	1500 lbs

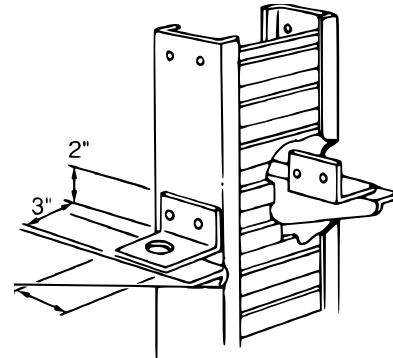
*Uniform load rating is normally twice the end-load rating.



Tray Hanger & Supports

Vertical Support

- Tray Supports can be bolted anywhere along the straight runs
- They can be bolted directly onto the coupler plates at splices of straight runs and riser fittings, or they can be bolted at any place in the run by field-drilling side rails
- TROF supports are used with either 3/8" or 1/2" hanger rods
- Finish is electrogalvanized



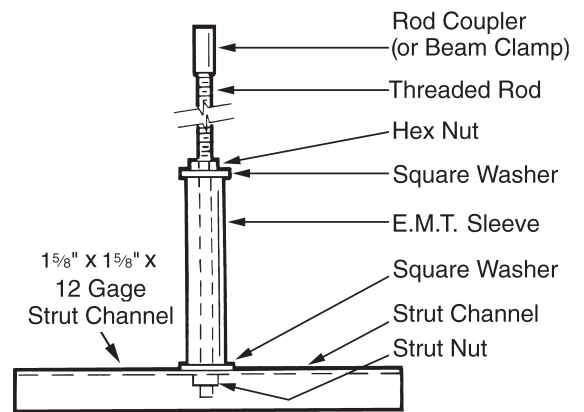
Catalog #	For Use With
9045	3 1/4" Overall Height Side Members
9043-37	4 1/4" Overall Height Side Members
9043	5 1/4" Overall Height Side Members
9025-98	6 1/4" & 7 1/4" Overall Height Side Members

Single Rod Hanger Support

- Other channel types and finishes available upon request; contact factory
- To order hardware only:
 - 3/8" - PGV380000
 - 1/2" - PGV120000

Example: P20020GV12036B is a Single 20" pre-galvanized channel with 1/2" x 36" drop rod and P2622 clamp

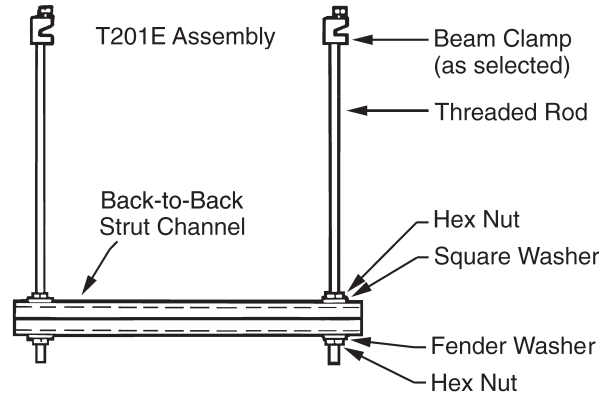
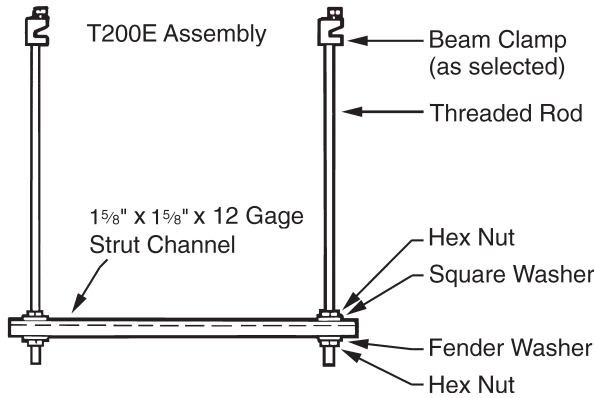
Note: Order channel length 8" longer than tray width
For example, 44" channel for 36" tray



Catalog #					
Assy. Type	Channel Length*	Channel Finish**	Rod Diameter	Rod Length	Beam Clamp
P200	14" (356mm)	GV (Pre-Galv)	38= 3/8" (9.53mm)	000 - No Rod	A - Bridgeport
	17" (432mm)		12= 1/2" (12.7mm)	036 - 36" (914mm)	B - P2622
	20" (508mm)	HG (Hot Dipped Galv)		072 - 72" (1828mm)	O - No Clamp
	26" (661mm)			120 - 120" (3048mm)	R - Rod Coupler
	32" (813mm)			144 - 144" (3658mm)	S - Special
	38" (966mm)				
	44" (1118mm)				

Electrical Grounding & Supports

Trapeze Hanger Support



Catalog

Assy. Type	Channel Length*	Channel Finish**	Rod Diameter	Rod Length	Beam Clamp
T200E	16" (407mm)	GV (Pre-Galv)	3/8" (9.53mm)	000 - No Rod	A - PS 85
T201E	19" (483mm)	HG (Hot Dipped Galv)	1/2" (12.7mm)	036 - 36" (914mm)	B - P2622
	22" (559mm)			072 - 72" (1828mm)	O - No Clamp
	28" (712mm)			120 - 120" (3048mm)	R - Rod Coupler
	34" (864mm)			144 - 144" (3658mm)	S - Special
	40" (1017mm)				
	46" (1169mm)				

Example: T200E22GV12036B is a Single 22" pre-galvanized channel with 1/2" x 36" drop rod and P2622 clamp.

Note: *Order channel length 10" longer than tray width. For example, 46" channel for 36" tray.

** Other channel types and finishes available upon request. Contact factory.

To order hardware only:

3/8" - PGV380000

1/2" - PGV120000



Electrical Grounding & Supports

Electrical Grounding Chart

Table 1 below provides the Minimum Cross Sectional area for two side rails. Using the Fitting Prefix Number (244), the proper value is determined by the Flange Width (column 1), Load Depth, (column 2), and material (column 3). Locate the line containing the Flange Width (column 1) and follow it to the right to the appropriate Load Depth and Material.

Find that value in Table 2, follow it to the right to the Material column to determine the Maximum Ground Fault Amperage.

Table 1

Fitting Prefix Number			Min. X-Sect for 2 Rails (NEC Table 392.60(A))			
Flange	Load Depth	Material	Aluminum		Steel	
			¹ / ₁₆ " Flange	¹ / ₄ " Flange	¹ / ₁₆ " Flange	¹ / ₄ " Flange
			X-Sect Area	X-Sect Area	X-Sect Area	X-Sect Area
2 - ¹ / ₁₆ "	3"	2 - Mill-Galv	0.60	-	0.40	-
4 - ¹ / ₄ "	4"	3 - HDGAF	0.60	0.60	0.40	0.70
	5"	4 - Alum.	0.60	1.00	0.70	0.70
	6"		0.60	1.00	0.70	1.00

Table 2

X-Sect Area	Maximum Ground Fault Amperage (in Amps)	
	Material	
	Aluminum	Steel
0.40 in ²	-	100
0.60 in ²	1000	-
0.70 in ²	-	200
1.00 in ²	1200	400

For Example:

If the fitting prefix is 244, the Flange is ¹/₁₆", the Load Depth is 4", and the Material is Aluminum. The Minimum Cross Sectional Area (X-Sect Area) is 0.60 in². The Amperage is 1000.



Typical Specifications

By Specifying the NEMA class designation, you will use the simplest, clearest, and most complete method of specification available and automatically incorporate support span in feet, working (allowable) load in pounds per linear foot, a safety factor of 1.5, a concentrated load (if present), and all other design, manufacturing and test standards including electrical continuity.

All you need to add is inside depth, desired radius of fittings (to protect from cable

damage), metal and finish. You can add accessory information pursuant to your project. Here is a typical specification for an outdoor tray system where the working (allowable) load has been determined to be approximately 75 pounds per foot on support spans of 12'-0".

Specification - Aluminum Cope Trof

Cable Trof type tray shall be manufactured by a company regularly engaged in the manufacture of metal cable trays and shall be a member of NEMA. Trays shall conform to NEMA Metal Cable Tray Standard Publication VE-1 (latest issue).

1. Cable Trof shall be NEMA Classification 12B of the widths indicated.
2. Material shall be aluminum alloy with side rails of 6063 and bottoms of 5052 alloy.
3. Finish shall be natural.
4. Inside load depth to be NEMA Standard 3.
5. Fittings shall be 12" radius for control cables and 24" radius for power cables. (This must be commensurate with the cable manufacturer's recommended minimum bending radius.)
6. All top level trays in stacks and single runs to have raised peaked aluminum ventilated covers with heavy duty hold down clamps every 3'-0".
7. Install expansion connectors, expansion guides, and hold down clamps per NEMA Standard VE-1.
8. Where slopes or horizontal bends of trays are not at the Standard NEMA angles use adjustable connectors. If the angle is too great for cable bending radius, use combinations of fitting and adjustable connectors.
9. Separate all cables of different voltages in the same tray using the manufacturer's standard barriers and barrier hold down system.
10. The cable Trof system will be used as an equipment grounding conductor.
11. To save space, fittings shall have no tangents. To facilitate field installation, use one pair of universal type connector plates for rigid joints.
12. Cable Trof shall be three (3) piece construction with corrugated bottoms having 1" wide ribs on 2" centers arc welded to 3 ½" high side rails. Ventilating holes, 1¼" diameter on 1" centers, shall be provided across valleys of the corrugations. Welds shall be MIG-arc type with approximately ½" diameter fused zone for rigidity to resist the rigors of shipping, installation, and service.
13. Trays shall be Cope Trof as manufactured by Cope.



EAGLE BASKET™



**Cable Tray for Data Centers
and Fiber Optics**



Table of Contents

Introduction 127

Markets Served 128

Made In The USA 129

Quick-Latch 130

Materials And Finishes 131

2" Deep Eagle Basket..... 132

4" Deep Eagle Basket..... 133

6" Deep Eagle Basket..... 134

Splicing 135

Grounding 138

Covers, Dividers, Liners 139

Mounting (Hangers, Supports, Brackets)..... 140

Ground / Underfloor Supports 145

Accessories..... 147

Fitting Overview / Assembly 151



Eagle Basket

Soar To New Heights With Eagle Basket!

Cope - The Leader In Customer Experience

Started in 2012, with the clients as the focus, the Cope team brings together a diverse combination of talents from a long history in the cable tray industry. The dedication to QUALITY, SERVICE and RELIABILITY has established Cope as an industry leading manufacturer.

Designed for You, by You

EAGLE BASKET was designed and developed with one thing in mind - the customer! EAGLE BASKET is the ONLY zero-hardware solution in the cable management industry, minimizing installation time and costs. With five stocking locations across the U.S. and dedicated engineering services, Cope provides best-in-class delivery and customer experience.

EAGLE BASKET accessories come with a "TAB" or "LANCE" feature for securing to wire basket without any hardware. The only tool required is a pair of pliers or screwdriver to bend the TAB or LANCE feature around the wire basket grid for a secure assembly.

Partnering for the Future

Cope, a part of Atkore™, is focused on developing new innovative products, product enhancements, and unrivaled service to the electrical raceway industry. Atkore is constantly looking for ways to improve existing products and embracing new cable management methods. Choose Atkore to be your wire and cable management partner for the future - building better together.



Eagle Basket Applications

Data Centers & Fiber Optics

Powder coated Eagle Baskets are most often used in data centers to eliminate the risk of zinc whiskers getting into sensitive computer equipment. The open structure efficiency, with the option of dropping cables out from any part of cable trays, makes Eagle Basket ideal for these applications.



Commercial & Office

With its modern look and the option for custom colors, Eagle Basket is a great solution for open office concept applications. The lightweight and high efficiency design minimizes installation and operating costs.



Industrial

With two stainless steel and a HDGAF (hot dipped galvanized after fabrication) finish, these Eagle Baskets can withstand the most corrosive and demanding environments including food processing, salt/marine, and any outdoor applications.



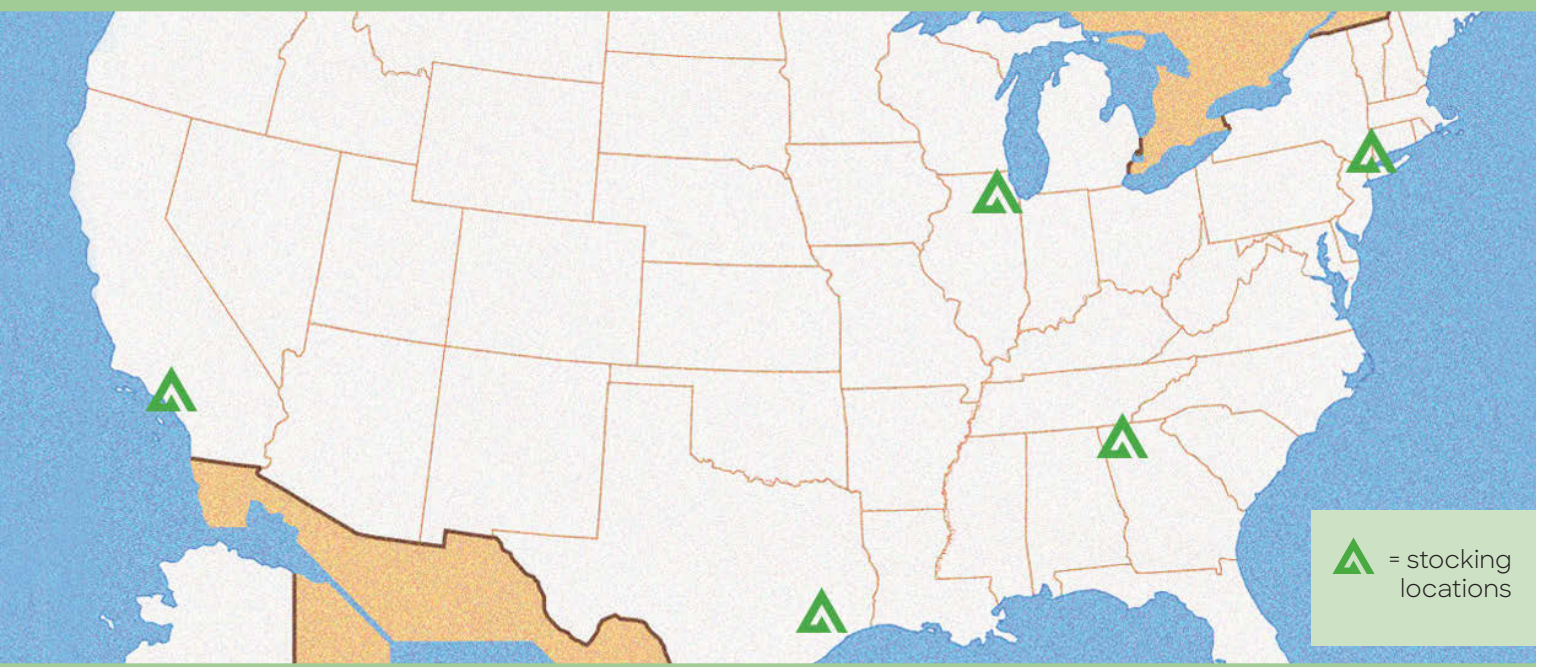
Hospitals & Schools

The need for speedy installation and the highly flexible Eagle Basket system appeals to these applications which are often subject to modifications and expansion. Unlike cable tray, Eagle Basket doesn't require custom ordered fittings, and the extensive offering of accessories is perfectly suited for runway upgrades and growth.



Eagle Basket

Made in the U.S.A.



American Made and Stocked Across The U.S.A. to Meet Your Needs

EAGLE BASKET is a welded wire mesh cable management system produced from the highest quality steel wires, one of the strongest in the industry. The 2"x4" mesh permits continuous airflow to prevent heat buildup as well as dust and other contaminants. The full line of QUICK-LATCH accessories is ideal for design-builds and expansion to existing grids, making installation fast and simple.

- Made in America – meets BUY AMERICA and BUY AMERICAN
- Manufactured by United Steelworkers of America
- Supports other Atkore brands
- Stocking locations across the U.S.A.
- Excludes some accessories

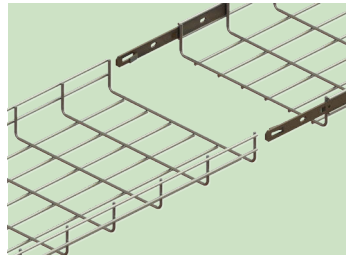
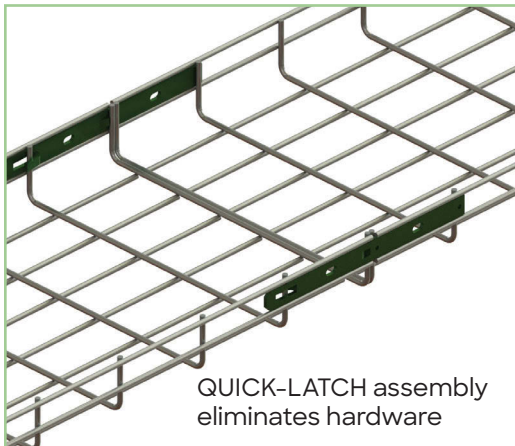
Standard Basket Size Chart - Additional Sizes Available Upon Request

2" Depth	4" Depth	6" Depth
EGL2-02SL-120	EGL4-04SL-120	EGL6-06SL-120
EGL2-04SL-120	EGL4-06SL-120	EGL6-08SL-120
EGL2-06SL-120	EGL4-08SL-120	EGL6-12SL-120
EGL2-08SL-120	EGL4-12SL-120	EGL6-16SL-120
EGL2-12SL-120	EGL4-16SL-120	EGL6-18SL-120
EGL2-16SL-120	EGL4-18SL-120	EGL6-20SL-120
EGL2-18SL-120	EGL4-20SL-120	EGL6-24SL-120
EGL2-20SL-120	EGL4-24SL-120	
EGL2-24SL-120		

QUICK-LATCH™

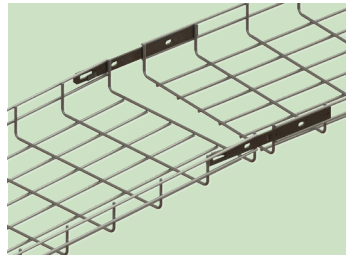
The Industry's only zero-hardware solution for all tray sizes

The QUICK-LATCH™ splicing system makes connecting EAGLE BASKET fast and easy. The QUICK-LATCH or self-splicing bars come pre-installed on ALL Eagle Basket straight lengths, eliminating the need for nut and bolt type connections. The AUTOLOCK is built into the QUICK-LATCH which locks the trays into place for a secure connection. For proper grounding of Eagle Basket please refer to page 138.



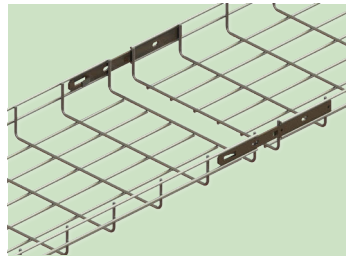
Step 1

Align the trays as shown



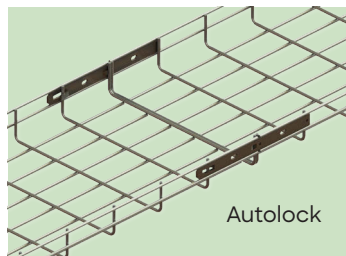
Step 2

While raising the edge of the tray with QUICK-LATCH slide the tray forward but do not engage the AUTO-LOCK



Step 3

Lower the edge of the QUICK-LATCH over the back edge of the tray



Step 4

Slide the tray forward to engage QUICK-LATCH and AUTO-LOCK

Splice straight lengths for field cuts with zero hardware



Eagle Basket

Eagle Basket Materials and Finishes

EAGLE BASKET is offered in a wide variety of materials and finishes to meet all of your environmental and aesthetic requirements.

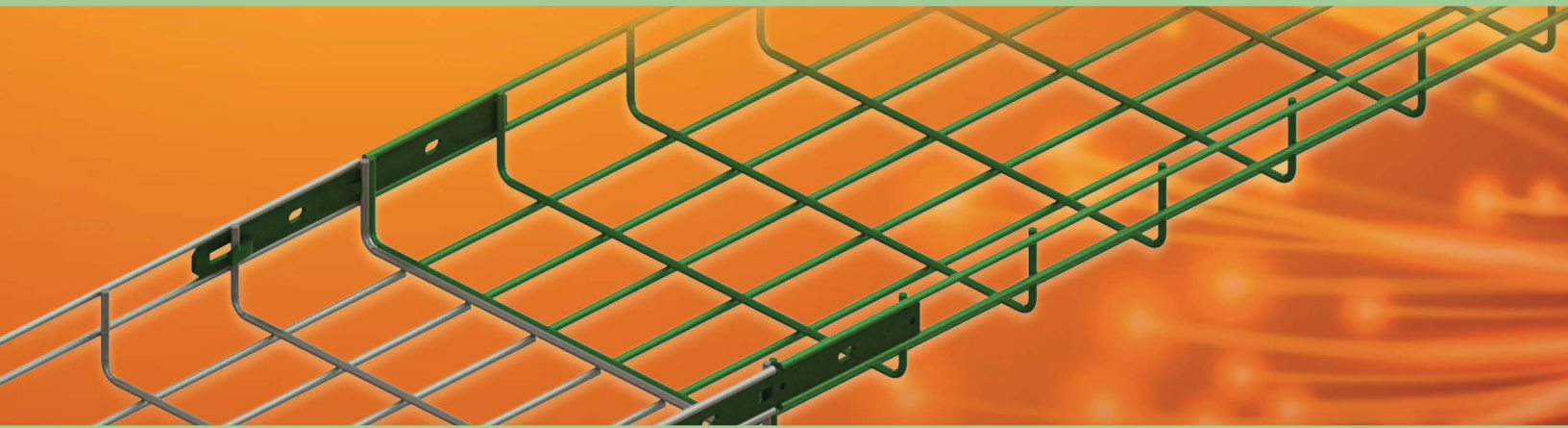


Suffix	Material	Finish	Controlled Interior	Exterior	Oil/Gas Petrochemical	Food Processing	Highly Corrosive Applications
No suffix needed	ASTM A 510 GRADE 1008	Electroplated zinc galvanized after fabrication ASTM B633	X				
HDG	ASTM A 510 GRADE 1008	Hot Dipped Galvanized after fabrication ASTM 123		X	X		
SS	304L Stainless Steel	ASTM A580		X	X	X	
S1	316L Stainless Steel	ASTM A580		X	X	X	X
PCWT	ASTM A 510 GRADE 1008	White powder coat finish after application	X				
PCBK	ASTM A 510 GRADE 1008	Black powder coat finish after application	X				
PC(X)	ASTM A 510 GRADE 1008	Custom powder coat finish after application e.g. PCY = Powder coat yellow	X				

Eagle Basket Product Code - Use when Ordering or Specifying Eagle Basket

Tray Type	Load Depth (in)		Width (in)	Straight Length		Length (in)
EGL	H	-	WW	SL	-	120

For example: EGL2-24SL-120 is the product code for 2" load depth, 24" wide Eagle Basket



Eagle Basket - 2" Load Depth

Features

- Double rod reinforced tray is 2" high
- Standard length of tray is 10'
- Additional widths available upon request
- Standard finish is electro-galvanized (EG)
- Zero hardware to connect straight lengths
- For continuous grounding use EGL-GC
 - See page 138



EGL2-(WW)SL-120

Approvals		Part Description	Nominal Width	Wire Diameter	Weight (piece)	Loading (lb/ft)				
UL	cUL					5' Span	6' Span	8' Span	9' Span	
			EGL2-02SL-120	2" (50 mm)	0.197"	4.6 lbs	60	42	23	19
			EGL2-04SL-120	4" (100 mm)	0.197"	6.8 lbs	60	42	23	19
			EGL2-06SL-120	6" (150 mm)	0.197"	8.0 lbs	60	42	23	19
			EGL2-08SL-120	8" (200 mm)	0.197"	9.3 lbs	89	62	35	27
			EGL2-12SL-120	12" (300 mm)	0.197"	14.5 lbs	89	62	35	27
			EGL2-16SL-120	16" (400 mm)	0.197"	25.3 lbs	149	103	58	46
			EGL2-18SL-120	18" (450 mm)	0.197"	27.6 lbs	149	103	58	46
			EGL2-20SL-120	20" (500 mm)	0.197"	29.8 lbs	149	103	58	46
			EGL2-24SL-120	24" (600 mm)	0.197"	34.3 lbs	149	103	58	46



Eagle Basket



Eagle Basket - 4" Load Depth

Features

- Triple rod reinforced tray is 4" high
- Standard length of tray is 10'
- Additional widths available upon request
- Standard finish is electro-galvanized (EG)
- Zero hardware to connect straight lengths
- For continuous grounding use EGL-GC
- See page 138



EGL4-(WW)SL-120

Approvals		Part Description	Nominal Width	Wire Diameter	Weight (piece)	Loading (lb/ft)				
UL	cUL					5' Span	6' Span	8' Span	9' Span	
			EGL4-04SL-120	4" (100 mm)	0.197"	9.3 lbs	108	75	42	33
			EGL4-06SL-120	6" (150 mm)	0.197"	11.9 lbs	108	75	42	33
			EGL4-08SL-120	8" (200 mm)	0.197"	14.5 lbs	108	75	42	33
			EGL4-12SL-120	12" (300 mm)	0.197"	25.3 lbs	182	127	71	56
			EGL4-16SL-120	16" (400 mm)	0.197"	29.8 lbs	182	127	71	56
			EGL4-18SL-120	18" (450 mm)	0.197"	32.0 lbs	182	127	71	56
			EGL4-20SL-120	20" (500 mm)	0.197"	34.3 lbs	182	127	71	56
			EGL4-24SL-120	24" (600 mm)	0.197"	38.8 lbs	182	127	71	56



Eagle Basket - 6" Load Depth

Features

- Quadruple rod reinforced tray is 6" high
- Standard length of tray is 10'
- Additional widths available upon request
- Standard finish is electro-galvanized (EG)
- Zero hardware to connect straight lengths
- For continuous grounding use EGL-GC
- See page 138



EGL6-(WW)SL-120

Approvals		Part Description	Nominal Width	Wire Diameter	Weight (piece)	Loading (lb/ft)				
UL	cUL					5' Span	6' Span	8' Span	9' Span	
			EGL6-06SL-120	6" (150 mm)	0.197"	8.0 lbs	60	42	23	19
			EGL6-08SL-120	8" (200 mm)	0.197"	25.3 lbs	235	163	92	73
			EGL6-12SL-120	12" (300 mm)	0.197"	29.8 lbs	235	163	92	73
			EGL6-16SL-120	16" (400 mm)	0.197"	34.3 lbs	235	163	92	73
			EGL6-18SL-120	18" (450 mm)	0.197"	36.4 lbs	235	163	92	73
			EGL6-20SL-120	20" (500 mm)	0.197"	38.8 lbs	235	163	92	73
			EGL6-24SL-120	24" (600 mm)	0.197"	48.4 lbs	235	163	92	73

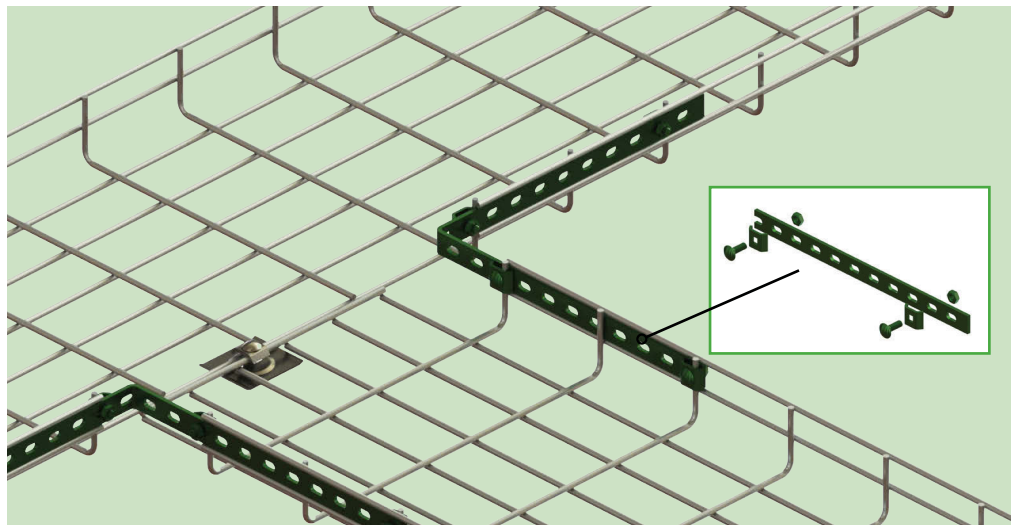
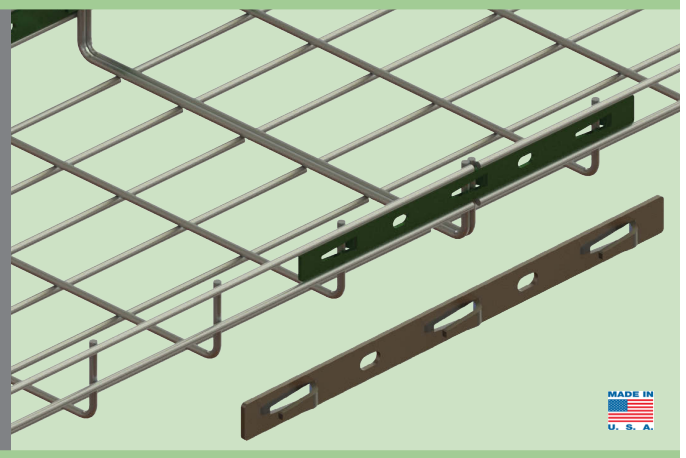


Eagle Basket

Splicing

QUICK-LATCH

- QUICK-LATCH assembles straight lengths at field cuts
- No hardware required
- UL approved as grounding path when used with EGL-GC and EG-CBN
- Sold individually



Notes:

1. Always place nut on outside of tray
2. For use with EGL2, EGL4 & EGL6 basket
3. Used for tees which require a heavier support
4. These bars are field cut to appropriate length

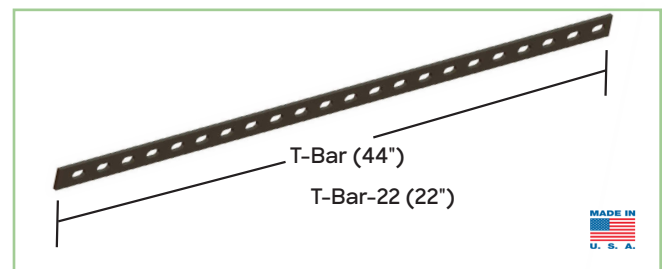
Fitting Splices

44" T-BAR

T-BAR

WEIGHT: 1.43 lbs/each

- T-BAR connector is 3/4" x 44" long
- Connect using CH3 (sold separately)
- Bend 90° for use as an angle connector

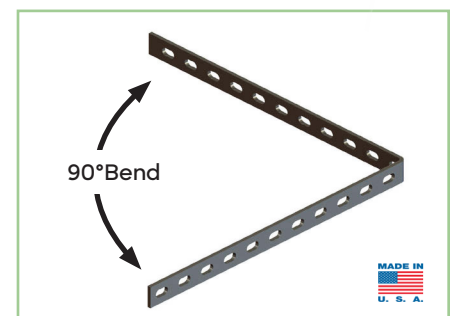


22" T-BAR

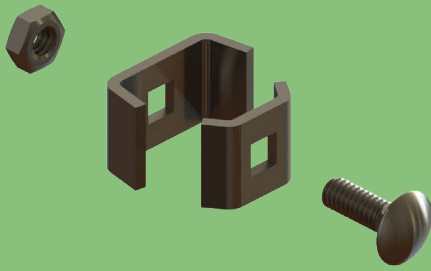
T-BAR-22

WEIGHT: .715 lbs/each

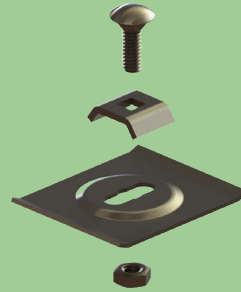
- T-BAR-22 connector is 3/4" x 22" long
- Connect using CH3 (sold separately)



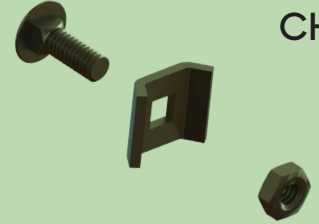
Connector Hardware Overview



CH1



CH2



CH3

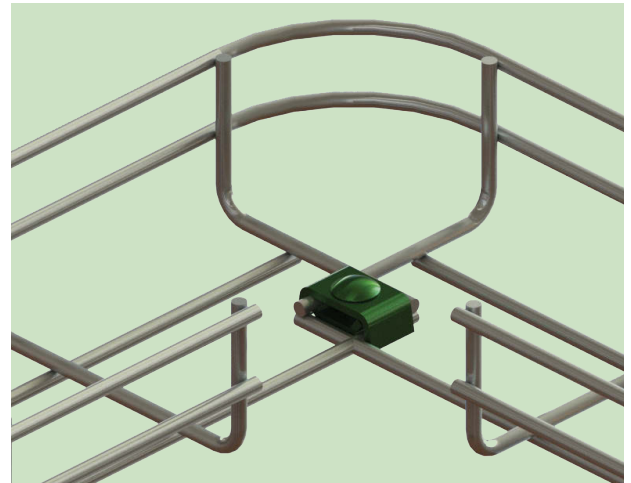
Fitting Hardware

Catalog

CH1

- Standard bar connector is 1 3/16" x 1 1/16"
- Standard finish is electro-galvanized (EG)
- Sold in packs of 10
- EG-CBN connector hardware included

Note: Always place nut on outside of tray

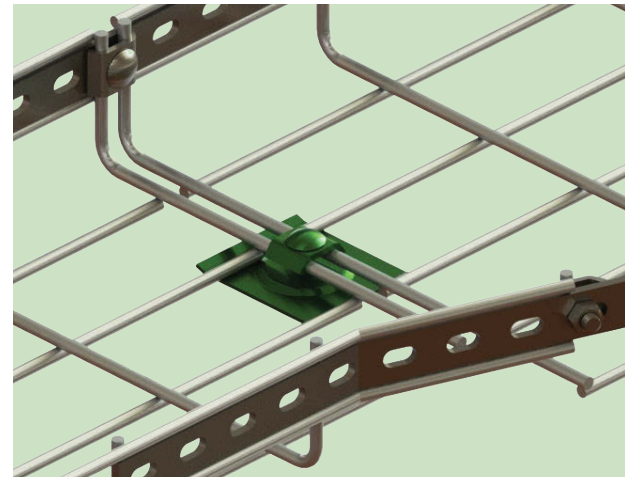


Catalog

CH2

- Bottom connector is 2" x 2 3/8"
- Standard finish is electro-galvanized (EG)
- Sold in packs of 10
- EG-CBN connector hardware included

Note: Always place nut on outside of tray



Eagle Basket



Fitting Hardware

Catalog # CH3

- Universal connector is 1 $\frac{1}{16}$ " x 1 $\frac{3}{16}$ "
- Standard finish is electro-galvanized (EG)
- Sold in packs of 10
- EG-CBN connector hardware included

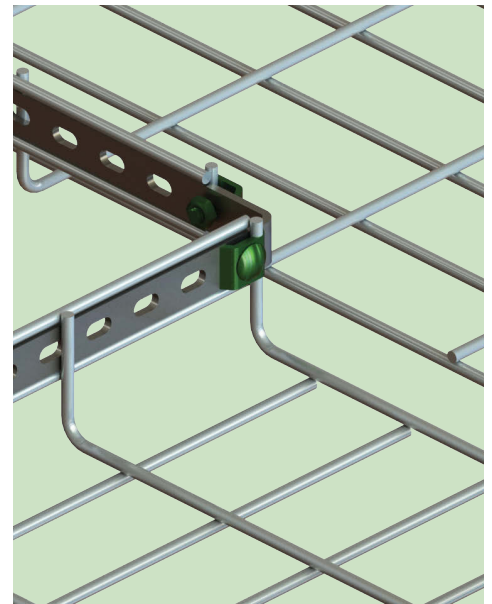
Note: Always place nut on outside of tray



Catalog # EG-CBN

- 1 $\frac{1}{4}$ "-20 X 3 $\frac{3}{4}$ " Carriage bolt
- 1 $\frac{1}{4}$ "-20 Hex head nut
- Standard finish is electro-galvanized (EG)
- Sold in packs of 10

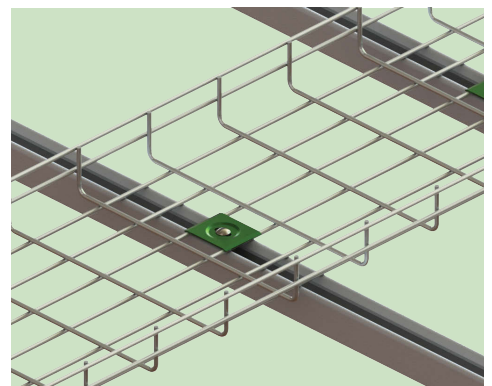
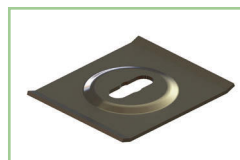
Note: Always place nut on outside of tray



Catalog # BOTTOM-CLIP

- Can be used as a hold down clip to relay racks and strut
- Sold in packs of 10
- Standard finish is electro-galvanized (EG)
- EG-CBN sold separately
- Up to 1 $\frac{1}{4}$ " diameter hardware for securing to strut

Note: Always place nut on outside of tray



Grounding

UL Classified Systems

Cope Eagle Basket systems meet the UL Classification

- Any non-conductive coating to Eagle Basket must be removed by the contractor/ end-user to maintain electrical continuity

STRAIGHT SECTIONS - The grounding of two straight sections requires the use of:

- (2) EGL-GC
- (2) EG-CBN

These items consist of grounding clips and the appropriate hardware for connecting to trays. One clip should be placed on both sides of the tray, attached at the QUICK-LATCH bar.

FITTINGS - Grounding a fitting requires special attention. Typically, fittings are fabricated in the field by cutting straight sections, thus altering the cross sectional area of the tray. A bonding jumper, and/or a T-BAR, along with the appropriate hardware must be used on either side of the fitting to ensure electrical continuity.



Grounding Clip

EGL-GC

- Standard finish is pre-galvanized (PG)
- Sold in packs of 10
- Connection to splice bars requires a nut and bolt assembly (EG-CBN) purchased separately
- Use on both sides of tray

Note: Always place nut on outside of tray

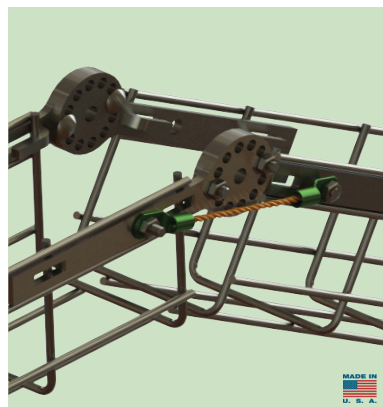
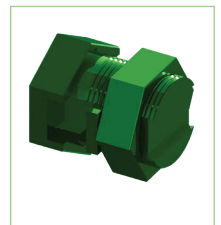


Grounding Wire Split Bolt

SPLIT-BOLT

- Split bolts are utilized for the attachment of a separate ground wire
- Use with #6 AWG Ground Conductor

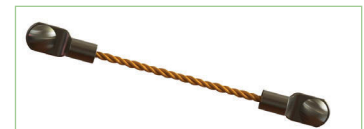
Note: Always place nut on outside of tray. EGL-GC must be installed if the tray is to be utilized as an equipment ground conductor.



Bonding Jumper

CBJ-C

- Order EGL-GC and EG-CBN separately for installation

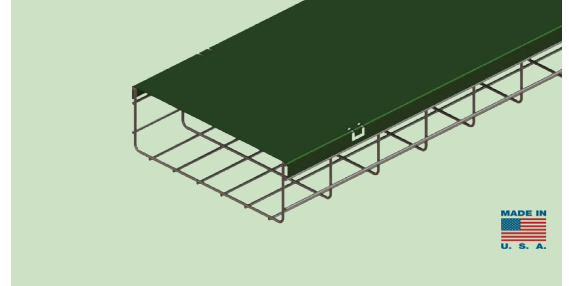


Eagle Basket

Covers / Liners

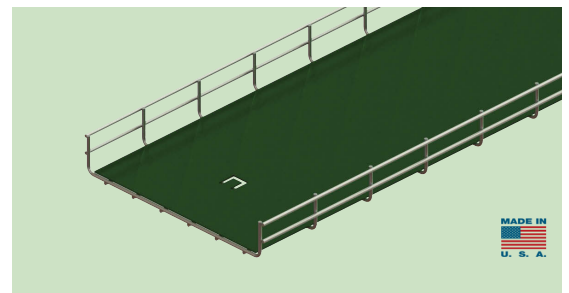
Cover EGL-CVR-(WW)

- Standard finish is pre-galvanized (PG)
- Length is 10'
- Easy mounting using the TAB feature to fasten the cover to basket



Liner EGL-LINER-(WW)

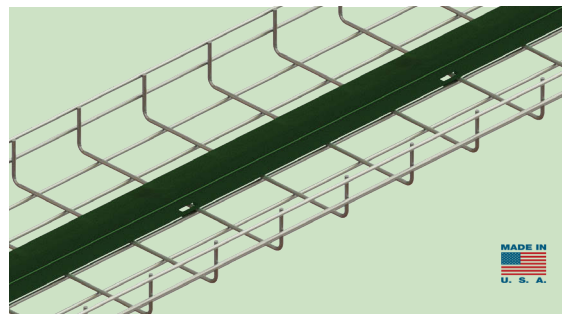
- Standard finish is pre-galvanized (PG)
- Length is 10'
- Easy mounting using the TAB feature to fasten the liner to basket



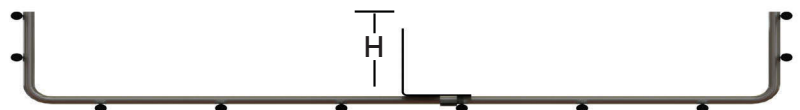
Dividers

Divider EGL(H)-01SB-120

- Standard finish is pre-galvanized (PG)
- Easy mounting using the LANCE feature to fasten the divider to basket
- Cut V into bottom flange to make barriers for horizontal fittings



Part	H Dimension	Weight
EGL2-01SB-120	1.60"	0.6 lbs
EGL4-01SB-120	3.60"	1.0 lbs
EGL6-01SB-120	5.60"	1.4 lbs



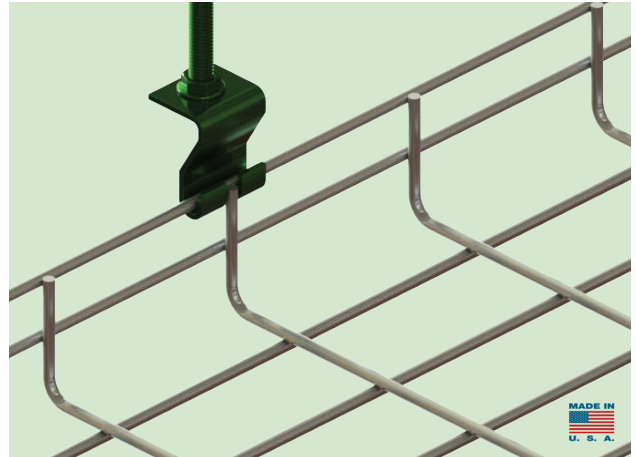
Mounting Drop Rod Clips

Side-Drop Rod Clip

WEIGHT: 0.13 lb/each

- Standard finish is pre-galvanized (PG)
- 0.08" Bracket thickness
- For all widths of tray

EGL-SIDE-DRC

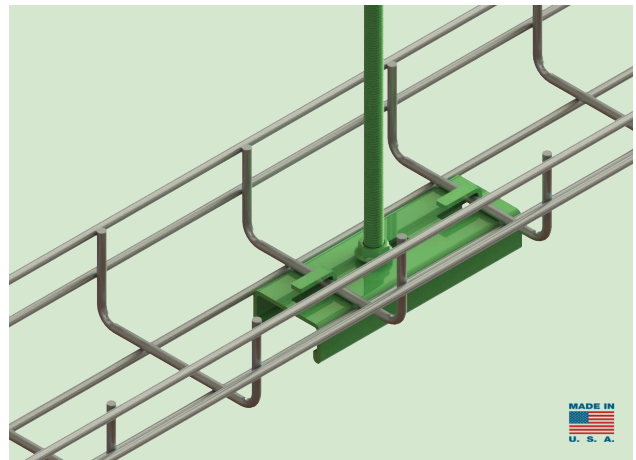


4"-6" Center-Drop Rod Clip

EGL-1x6-DRC

WEIGHT: 0.12 lb/each

- Standard finish is pre-galvanized (PG)
- 0.11" Bracket thickness
- For all 4" and 6" width tray
- Easy mounting of cable tray using the LANCE feature to fasten the tray to hanger

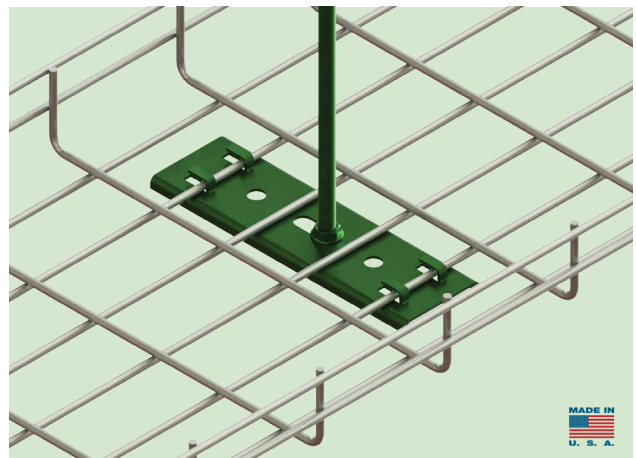


8"-12" Center-Drop Rod Clip

EGL-2x8-DRC

WEIGHT: 0.40 lb/each

- Standard finish is pre-galvanized (PG)
- 0.11" Bracket thickness
- For all 8" and 12" width tray
- Easy mounting of cable tray using the LANCE feature to fasten the tray to hanger



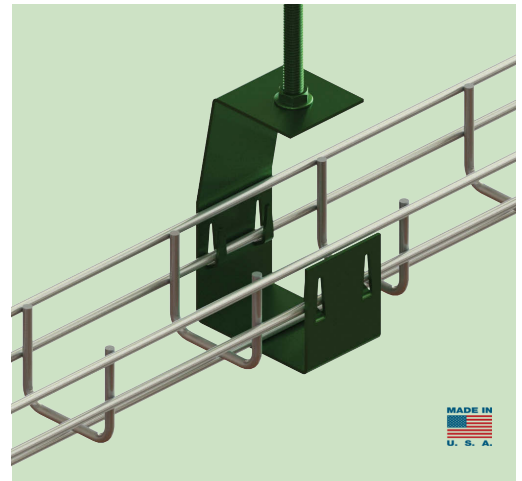
Eagle Basket

Mounting Hangers

2" Basket Hanger EGL-HGR-2

- Standard finish is pre-galvanized (PG)
- Ceiling or center hung with threaded rod
- Easy mounting of cable tray using the LANCE feature to fasten the tray to hanger

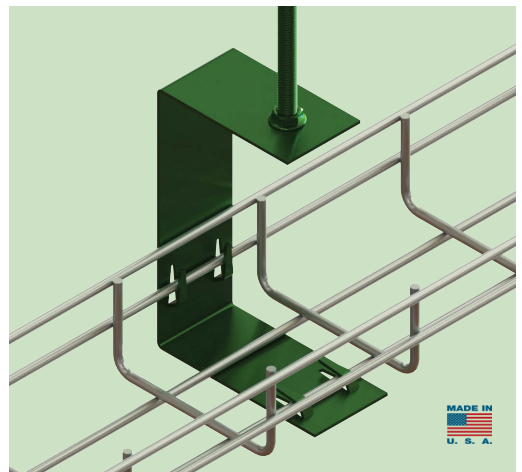
Note: For use with EGL2-02SL-120 only



4" Basket Hanger EGL-HGR-4

- Standard finish is pre-galvanized (PG)
- Ceiling or center hung with threaded rod
- Easy mounting of cable tray using the LANCE feature to fasten the tray to hanger

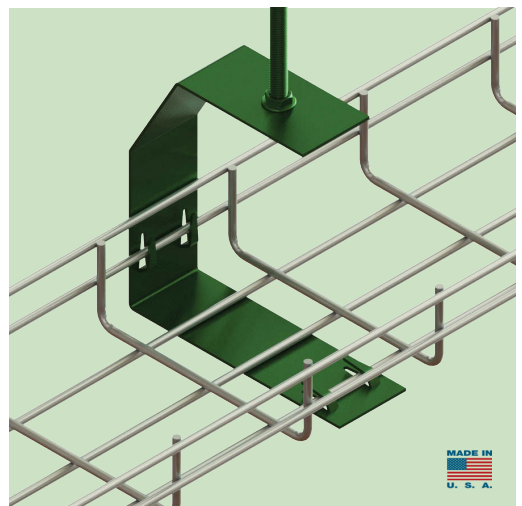
Note: For use with EGL2-04SL-120 only



6" Basket Hanger EGL-HGR-6

- Standard finish is pre-galvanized (PG)
- Ceiling or center hung with threaded rod
- Easy mounting of cable tray using the LANCE feature to fasten the tray to hanger

Note: For use with EGL2-06SL-120 only



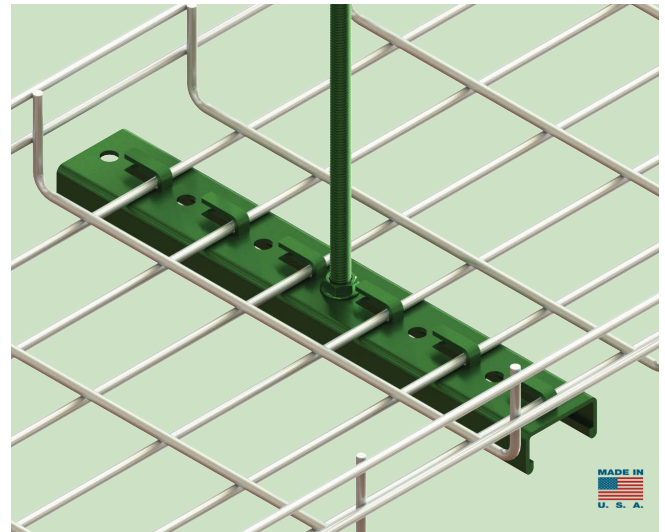
Mounting

Supports

Medium Support Bracket

EGL-MSB-(WW)

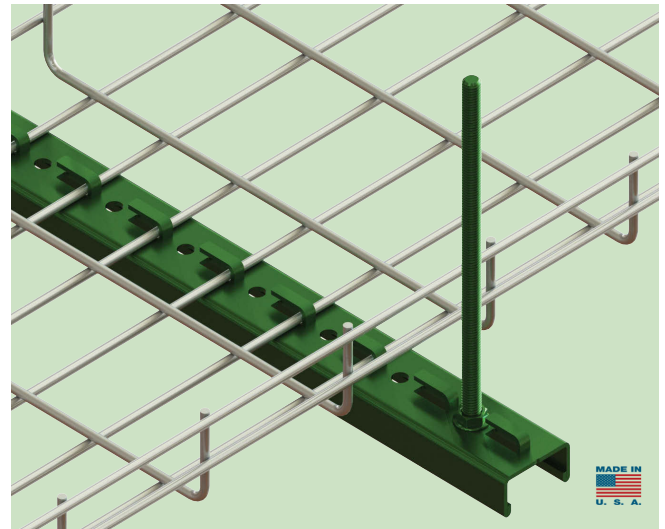
- 1 $\frac{5}{8}$ " x 1 $\frac{3}{16}$ " lanced strut
- Standard finish is pre-galvanized (PG)
- Used for trapeze and center hung supports
- Easy mounting of cable tray using the LANCE feature to fasten the basket to support



Heavy-Duty Support Bracket

EGL-HSB-(WW)

- 1 $\frac{5}{8}$ " x 1 $\frac{5}{8}$ " lanced strut
- Standard finish is pre-galvanized (PG)
- Used for trapeze and center hung supports
- Easy mounting of cable tray using the LANCE feature to fasten the basket to support



EGL-MSB-(WW)

Basket Width	Trapeze	Center Hung
8"	EGL-MSB-14	EGL-MSB-08
12"	EGL-MSB-18	EGL-MSB-12
16"	EGL-MSB-22	EGL-MSB-16
18"	EGL-MSB-24	EGL-MSB-18
20"	EGL-MSB-26	EGL-MSB-20
24"	EGL-MSB-30	EGL-MSB-24

EGL-HSB-(WW)

Basket Width	Trapeze	Center Hung
8"	EGL-HSB-14	EGL-HSB-08
12"	EGL-HSB-18	EGL-HSB-12
16"	EGL-HSB-22	EGL-HSB-16
18"	EGL-HSB-24	EGL-HSB-18
20"	EGL-HSB-26	EGL-HSB-20
24"	EGL-HSB-30	EGL-HSB-24

Eagle Basket



Wall Brackets

Medium Support Bracket

EGL-MWSB-(WW)

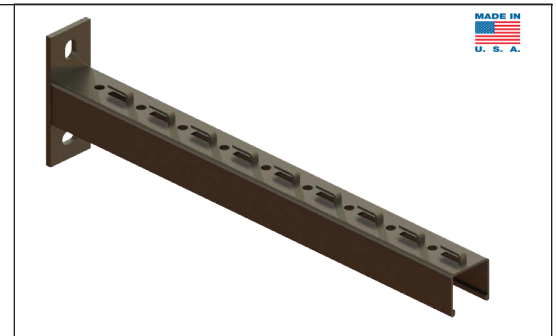
- 1⁵/₈" x 1³/₁₆" lanced strut
- Standard finish is pre-galvanized (PG)
- Used for trapeze and center hung supports
- Easy mounting of cable tray using the LANCE feature to fasten the basket to bracket



Heavy-Duty Support Bracket

EGL-HWSB-(WW)

- 1⁵/₈" x 1⁵/₈" lanced strut
- Standard finish is pre-galvanized (PG)
- Used for trapeze and center hung supports
- Easy mounting of cable tray using the LANCE feature to fasten the basket to bracket



EGL-MWSB-(WW) & EGL-HWSB-(WW)

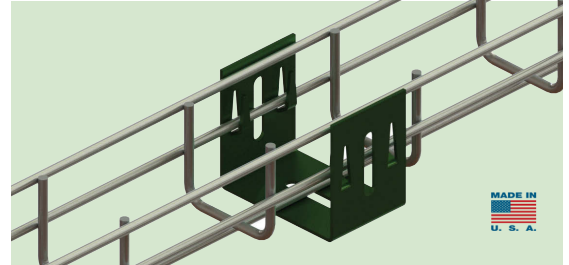
Part No.	Channel Size	Tray Width (W)	Length (L)	Weight	Load
EGL-MWSB-06	1- ⁵ / ₈ " X 1 ³ / ₁₆ "	6"	8"	1.3 lbs	270 lbs
EGL-MWSB-08	1- ⁵ / ₈ " X 1 ³ / ₁₆ "	8"	10"	1.5 lbs	225 lbs
EGL-MWSB-12	1- ⁵ / ₈ " X 1 ³ / ₁₆ "	12"	14"	1.9 lbs	157 lbs
EGL-HWSB-08	1- ⁵ / ₈ " X 1- ⁵ / ₈ "	8"	10"	1.9 lbs	562 lbs
EGL-HWSB-12	1- ⁵ / ₈ " X 1- ⁵ / ₈ "	12"	14"	2.5 lbs	450 lbs
EGL-HWSB-16	1- ⁵ / ₈ " X 1- ⁵ / ₈ "	16"	18"	2.8 lbs	350 lbs
EGL-HWSB-18	1- ⁵ / ₈ " X 1- ⁵ / ₈ "	18"	20"	3 lbs	337 lbs
EGL-HWSB-20	1- ⁵ / ₈ " X 1- ⁵ / ₈ "	20"	22"	3.6 lbs	292 lbs
EGL-HWSB-24	1- ⁵ / ₈ " X 1- ⁵ / ₈ "	24"	26"	4.1 lbs	247 lbs

Brackets

Wall Bracket EGL-WC-2

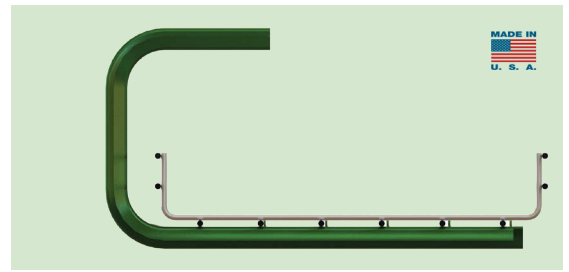
- Standard finish is pre-galvanized (PG)
- Easy mounting of cable tray using the LANCE feature to fasten the basket to bracket

Note: For use with EGL2-02SL-120 only



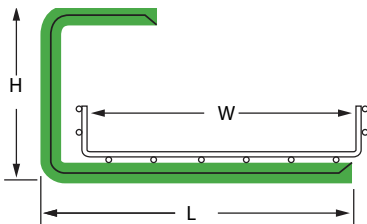
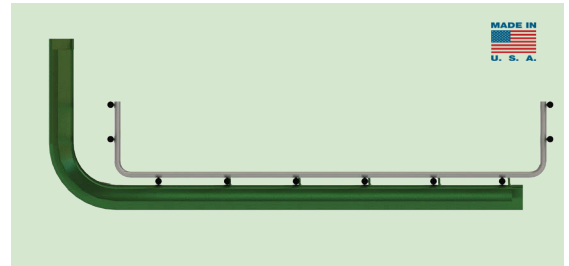
Ceiling Clip EGL-CCA-(WW)

- For attaching tray to ceiling
- Standard finish is pre-galvanized (PG)
- Easy mounting of cable tray using the LANCE feature to fasten the tray to the supports



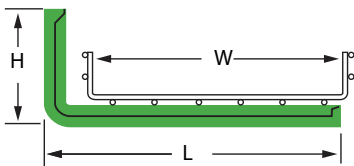
Wall Clip EGL-CPA-(WW)

- For attaching tray to wall
- Standard finish is pre-galvanized (PG)
- Easy mounting of cable tray using the LANCE feature to fasten the tray to the supports



EGL-CCA-(WW)

Part No.	Tray Size (W)	Height (H)	Length (L)	Weight	Load
EGL-CCA-04	4"	7"	6"	1.3 lbs	270 lbs
EGL-CCA-06	6"	7"	8"	1.5 lbs	225 lbs
EGL-CCA-08	8"	7"	10"	1.7 lbs	202 lbs
EGL-CCA-12	12"	7"	14"	2.0 lbs	180 lbs
EGL-CCA-16	16"	7"	18"	2.3 lbs	90 lbs



EGL-CPA-(WW)

Part No.	Tray Size (W)	Height (H)	Length (L)	Weight	Load
EGL-CPA-06	6"	5"	8"	1.0 lb	337 lbs
EGL-CPA-08	8"	5"	10"	1.1 lbs	225 lbs
EGL-CPA-12	12"	5"	14"	1.5 lbs	202 lbs
EGL-CPA-16	16"	5"	18"	1.8 lbs	90 lbs

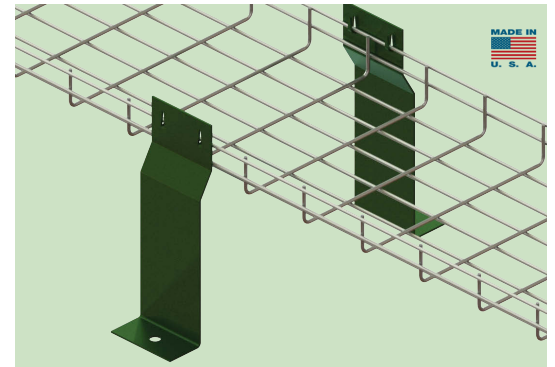
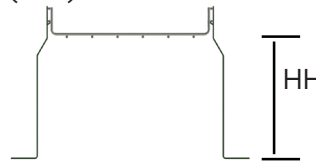
Eagle Basket

Ground and Underfloor Supports Floor Support



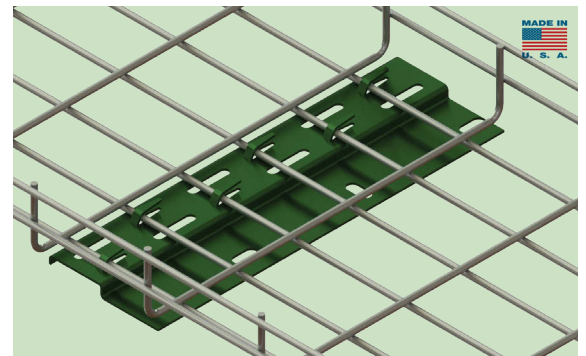
Floor Support EGL-FLR-SPRT-(HH)

- Supports basket directly above floor
- Elevation (HH), as specified by customer - 24" Maximum
- Standard finish is pre-galvanized (PG)
- Floor connection hardware not included
- Easy mounting of cable tray using the LANCE feature to fasten the tray to the supports



ZED Brackets EGL-ZBAR-(WW)

- ZED floor or wall mounted supports
- Pre-cut to length of Eagle Basket width (see chart below)
- Standard finish is pre-galvanized (PG)
- Easy mounting of cable tray using the LANCE feature to fasten the tray to the supports



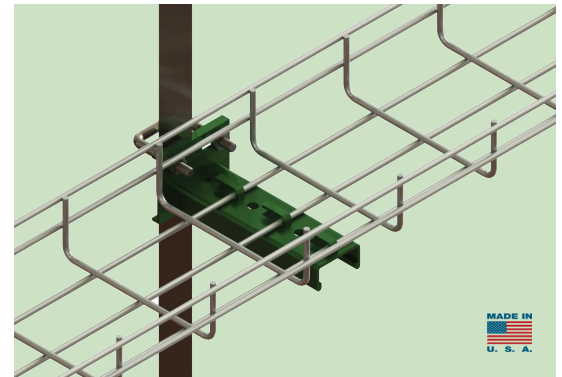
Part No.	Basket Width	WW Dimension
EGL-ZBAR-04	4"	4"
EGL-ZBAR-06	6"	6"
EGL-ZBAR-08	8"	8"
EGL-ZBAR-12	12"	12"
EGL-ZBAR-16	16"	16"
EGL-ZBAR-18	18"	18"
EGL-ZBAR-20	20"	20"
EGL-ZBAR-24	24"	24"

Ground and Underfloor Supports Pedestal Brackets & Kit

6" Pedestal Bracket

EGL-PED-06

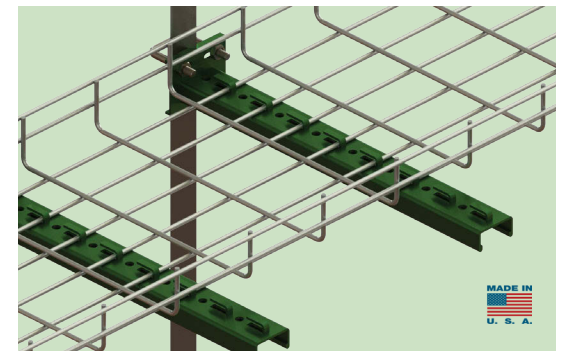
- Channels used on pedestals for raised floor
- Attach to pedestal using U-Bolt & nuts (included)
- Standard finish is pre-galvanized (PG)
- Easy mounting of cable tray using the LANCE feature to fasten the tray to the channel



12" Pedestal Bracket

EGL-PED-12

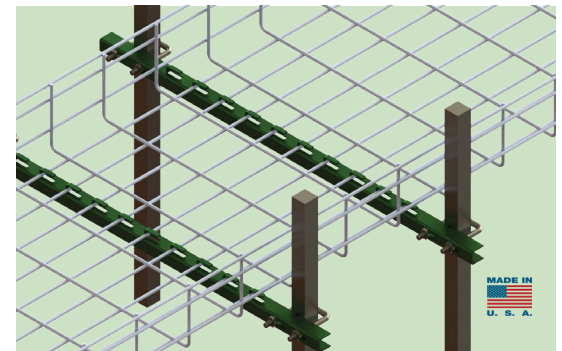
- Channels used on pedestals for raised floor
- Attach to pedestal using U-Bolt & nuts (included)
- Standard finish is pre-galvanized (PG)
- Easy mounting of cable tray using the LANCE feature to fasten the tray to the channel



Pedestal Kit

EGL-PED-KIT

- Channels used on pedestals for raised floor
- Attach to pedestal using U-Bolt & nuts (included)
- Standard finish is pre-galvanized (PG)
- Easy mounting of cable tray using the LANCE feature to fasten the tray to the channel



EGL-PED

Catalog No.	Tray Width (in)
EGL-PED-06	Up to 8
EGL-PED-12	Up to 12
EGL-PED-KIT	Up to 24

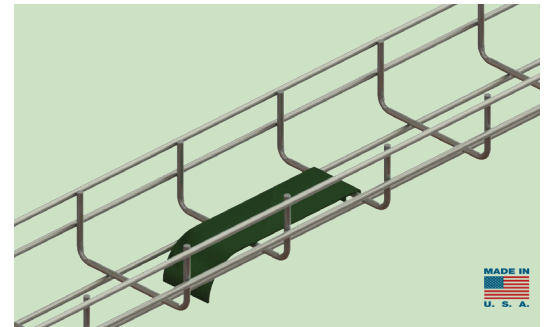
Eagle Basket

Accessories Dropouts

Universal Dropout

EGL-UNI-DO

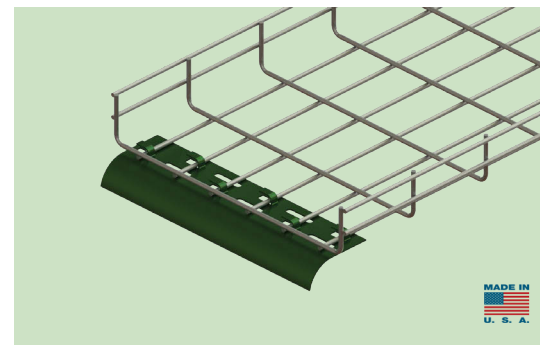
- Standard finish is pre-galvanized (PG)
- EGL-UNI-DO can be used in any 2"x4" mesh opening or as a side-out
- Standard finish is pre-galvanized (PG)
- Easy mounting using the LANCE feature to fasten the dropout to the tray



Waterfall Dropout

EGL-(WW)DO

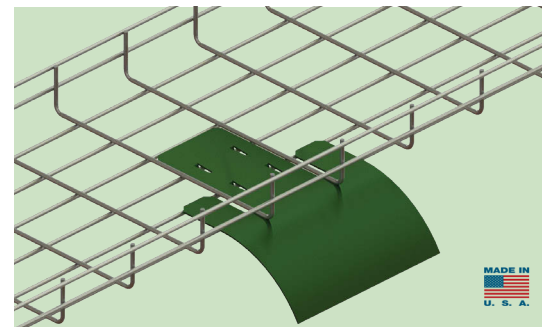
- Standard finish is pre-galvanized (PG)
- Drop cables out from end of basket
- Easy mounting using the LANCE feature to fasten the dropout to the tray
- Standard finish is pre-galvanized (PG)
- Contact for additional sizes



Side Dropout

EGL-(WW)SDO

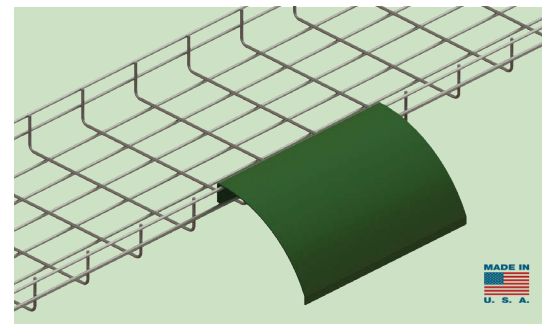
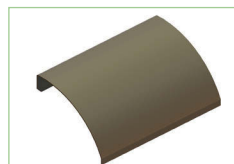
- Standard finish is pre-galvanized (PG)
- Drop cables out from side of basket
- Easy mounting using the LANCE feature to fasten the dropout to the tray
- Standard finish is pre-galvanized (PG)
- Contact for additional sizes



Over-The-Top Dropout

EGL-(WW)TDO

- Standard finish is pre-galvanized (PG)
- Drop cables out from the top of the basket
- Easy mounting using the LANCE feature to fasten the dropout to the tray
- Standard finish is pre-galvanized (PG)
- Contact for additional sizes

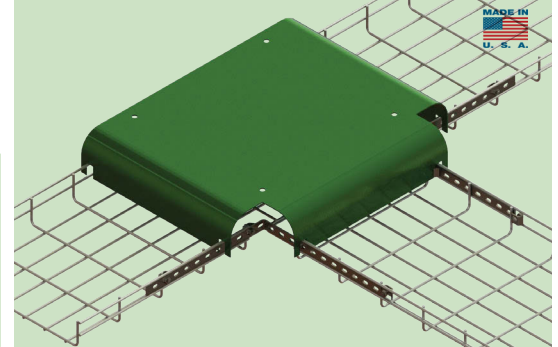
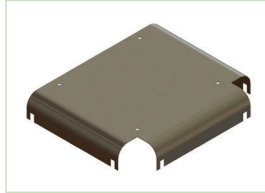


Accessories

Tee Bridge

EGL-(WW)TBR

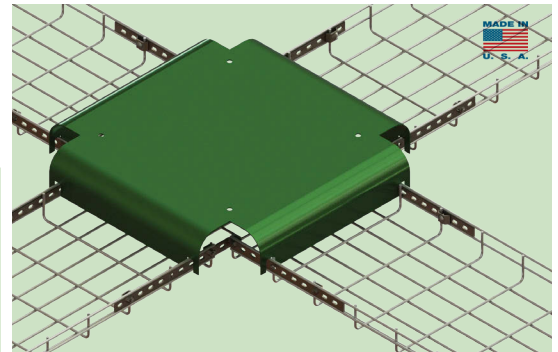
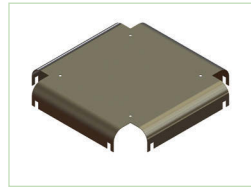
- Allows for organization and separation of cables in horizontal tee fittings
- Standard finish is pre-galvanized (PG)
- Available in reducing options
- Contact for additional sizes



Cross Bridge

EGL-(WW)XBR

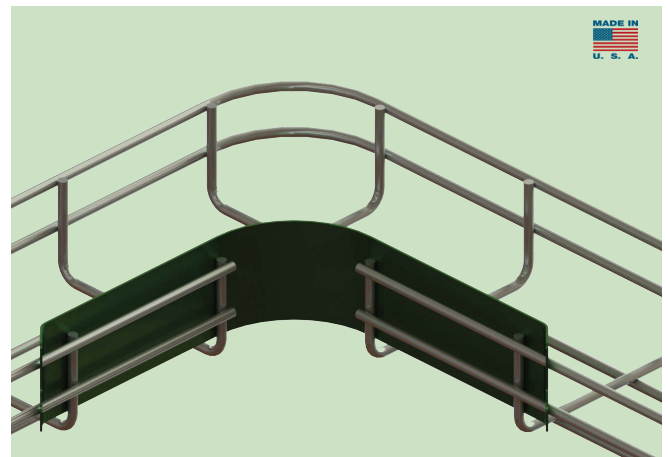
- Allows for organization and separation of cables in horizontal cross fittings
- Standard finish is pre-galvanized (PG)
- Available in reducing options
- Contact for additional sizes



Radius Shield

EGL(H)-RADIUS

- Used to maintain cable bend radius when routing or pulling cables through fittings
- Standard finish is pre-galvanized (PG)
- For short radius horizontal bends, long radius available



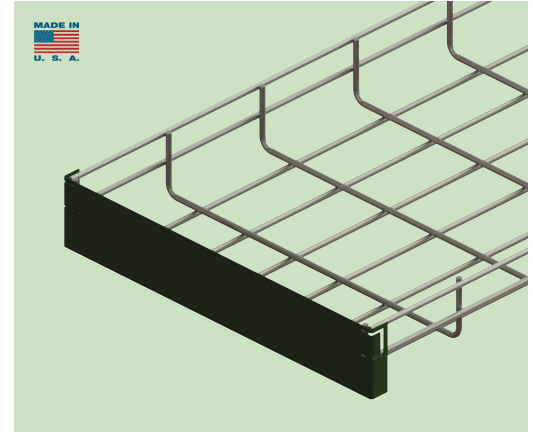
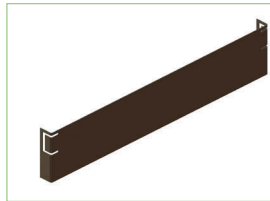
Eagle Basket

Accessories

Blind End

EGL(H)-(WW)BE

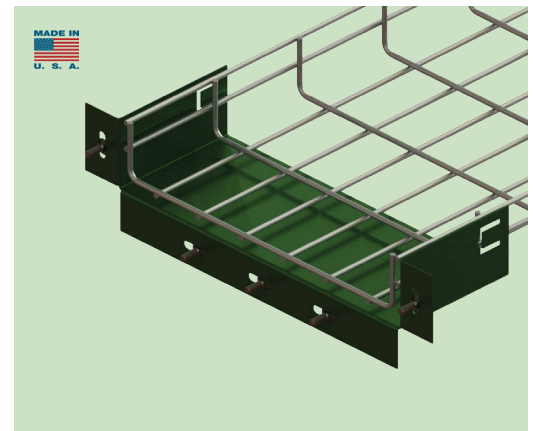
- Forms closure for EAGLE BASKET ends
- Standard finish is pre-galvanized (PG)
- Easy mounting using the TAB feature to fasten the blind end to the tray



Box Connector

EGL(H)-(WW)CB

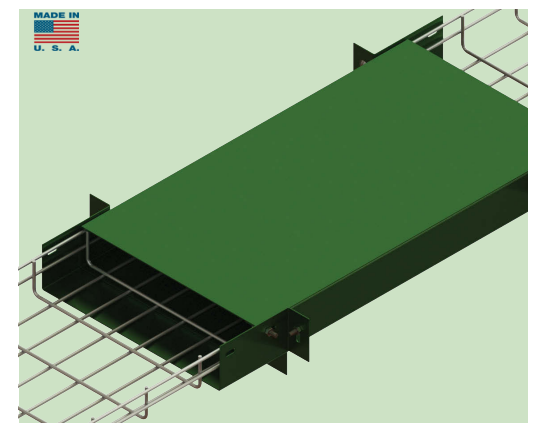
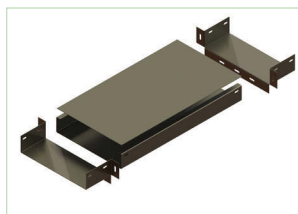
- Connects EAGLE BASKET to box devices
- Easy mounting using the TAB feature to fasten the box connector to the tray
- Standard finish is pre-galvanized (PG)
- Standard use per box connector is (5) EG-CBN - sold separately to connect to box device



Wall Sleeve

EGL(H)-(WW)WS

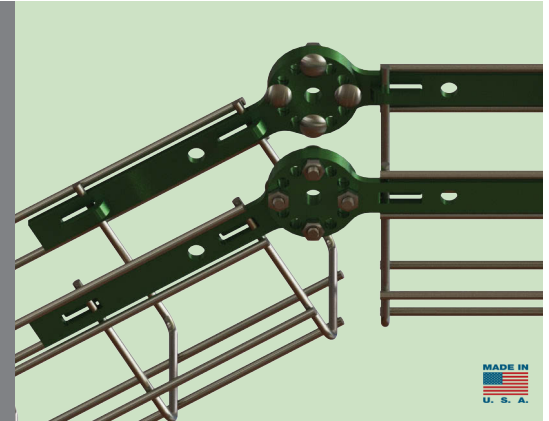
- Standard finish is pre-galvanized (PG)
- Standard use per wall sleeve is:
 - (4) CH3
 - (8) EM-CC
 - (4) 5003-1
 - (4) 5009-1



Accessories

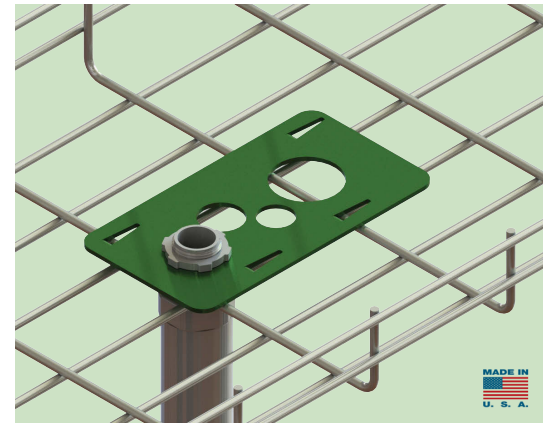
Elevation Change Kit EGL-VERT-KIT

- For supporting and reinforcing elevation changes
- Easy mounting using the LANCE feature to fasten the hinges to the tray
- Contains hardware to set adjustable angle



Conduit To Basket Clip EGL-EMT CLIP

- Two different latching configurations:
Configuration 1 accommodates ½", ¾" and 1" EMT Connectors
Configuration 2 accommodates ½", ¾" and 1-¼" EMT Connectors
- Bottom mounting for all load depth
- Side mounting for 4" and 6" load depth

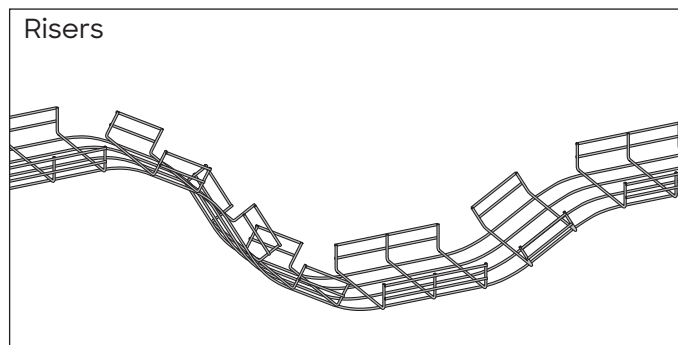
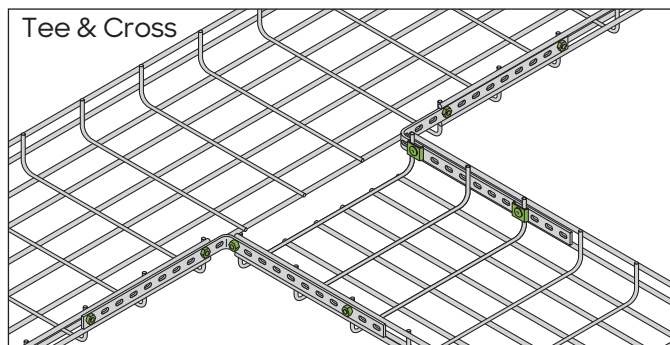
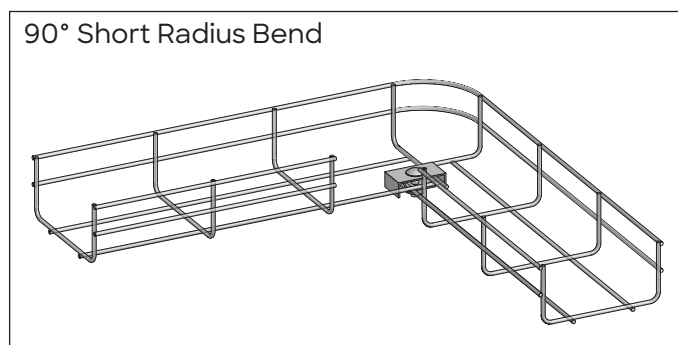
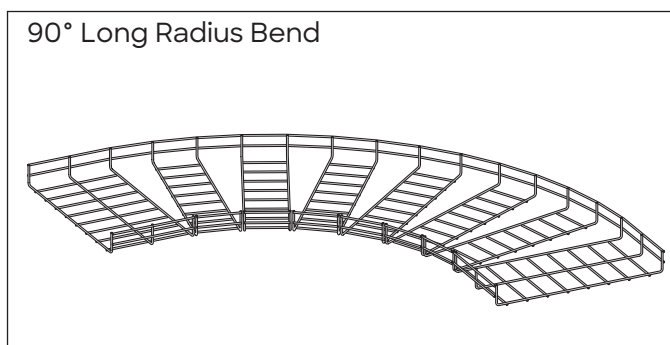


Eagle Basket

Fittings Overview / Assembly

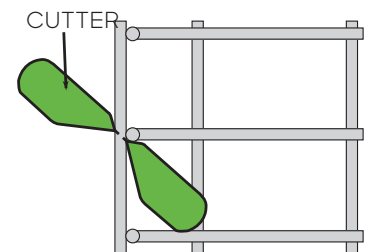
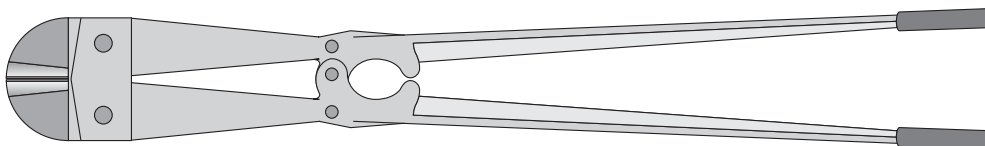
Fittings are typically fabricated on the job. However, prefabricated fittings are available upon request. Please contact factory for pricing and availability.

To determine the fitting hardware required to create a set of fittings, please consult our online calculator. [Choose Eagle Basket Component Calculator from the Resources/Links drop down menu on www.CopeCableTray.com]



Cutting Tool

Fittings can be formed easily on-site by cutting the bottom and side wires. Cut the tray bars on an angle as shown in the illustration.



Fittings Overview / Assembly

90° Short Radius Bends

1. Cut The Bottom And Side Wires

To form 90° bends in the tray, cut out the number of sections shown below based on the width of the tray used

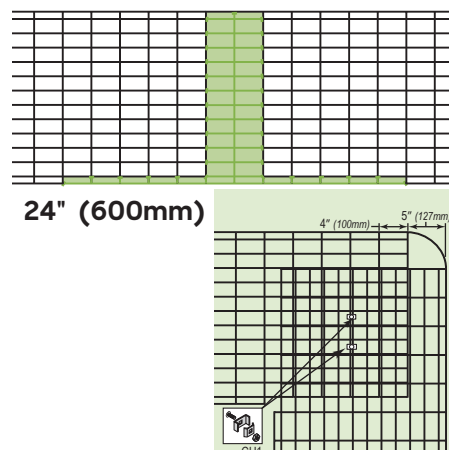
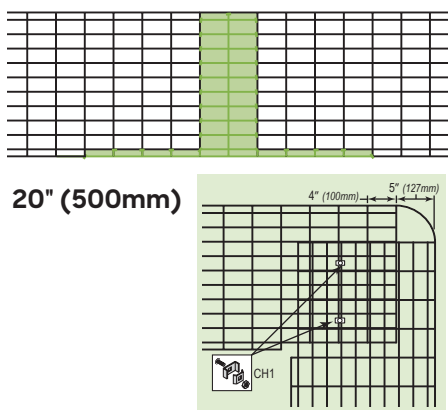
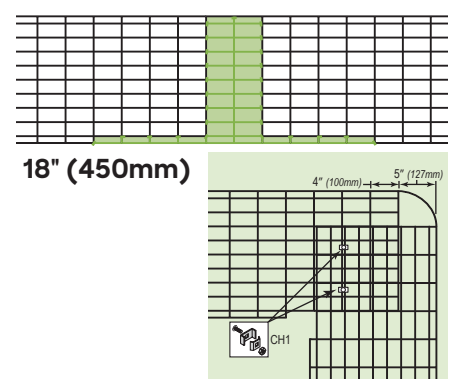
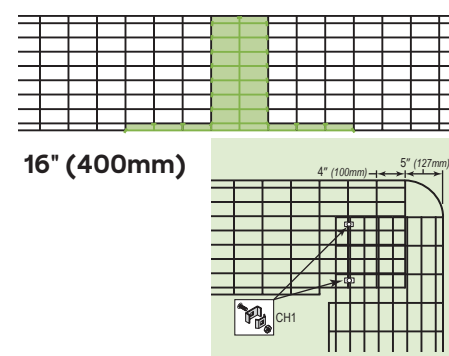
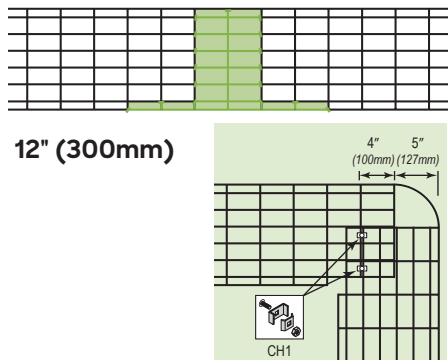
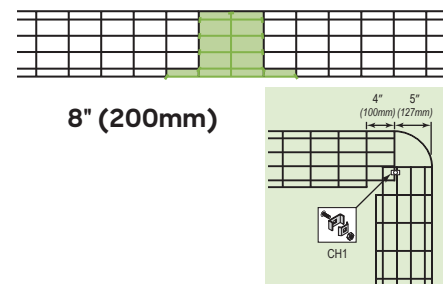
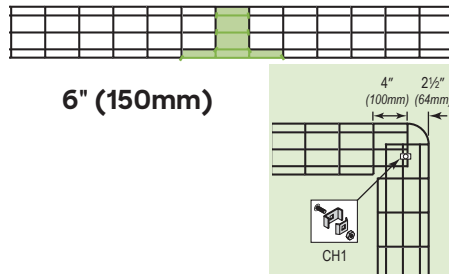
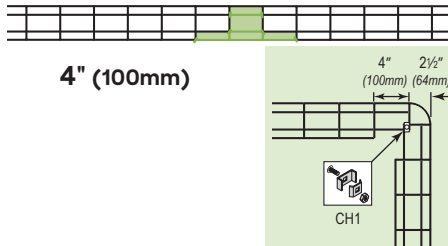
2. Assemble Using Appropriate Hardware

Standard hardware is shown with each bend size



Note: Standard hardware per width of cable tray

- 4"-12" (1) CH1
- 16"-24" (2) CH1



Eagle Basket

Fittings Overview / Assembly 90° Long Radius Bends

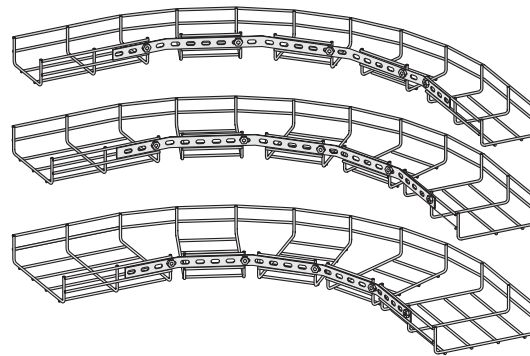
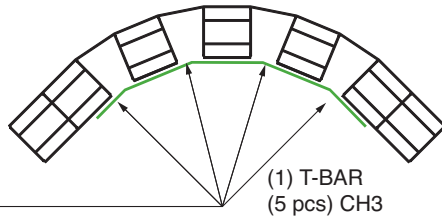
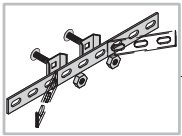
1. Cut The Bottom And Side Wires

To form 90° bends in the tray, cut out the number of sections shown below based on the width

2. Assemble Using Appropriate Hardware

Standard hardware is shown

Cut Out 4 Sections
of Mesh as Shown

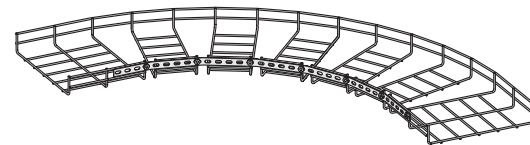
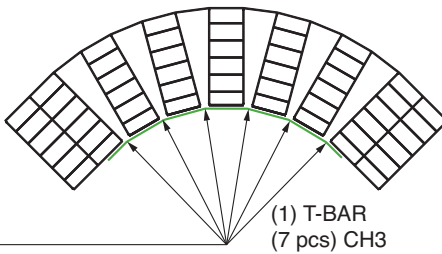
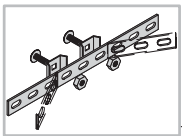


EGL2-04
16" Inside Radius

EGL2-06
12" Inside Radius

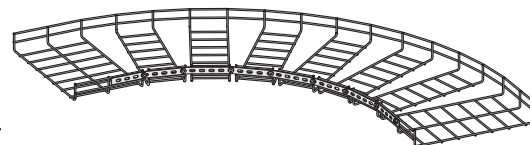
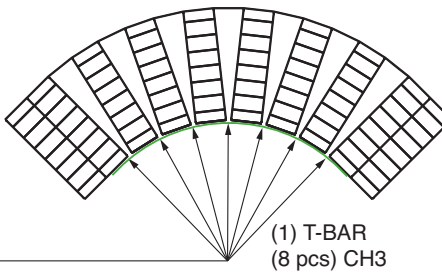
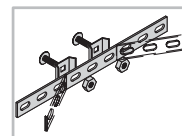
EGL2-08
12" Inside Radius

Cut Out 6 Sections
of Mesh as Shown

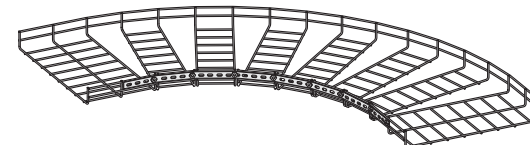


EGL2-12
17" Inside Radius

Cut Out 7 Sections
of Mesh as Shown

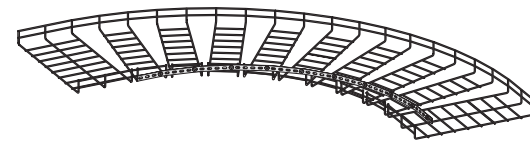
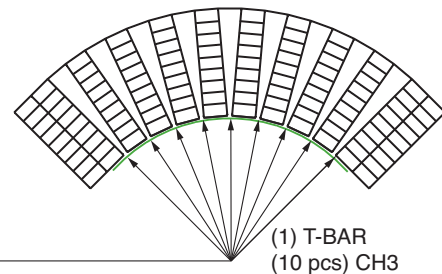
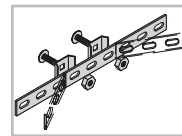


EGL2-16
18" Inside Radius



EGL2-18
18" Inside Radius

Cut Out 9 Sections
of Mesh as Shown



EGL2-20
24" Inside Radius



EGL2-24
24" Inside Radius

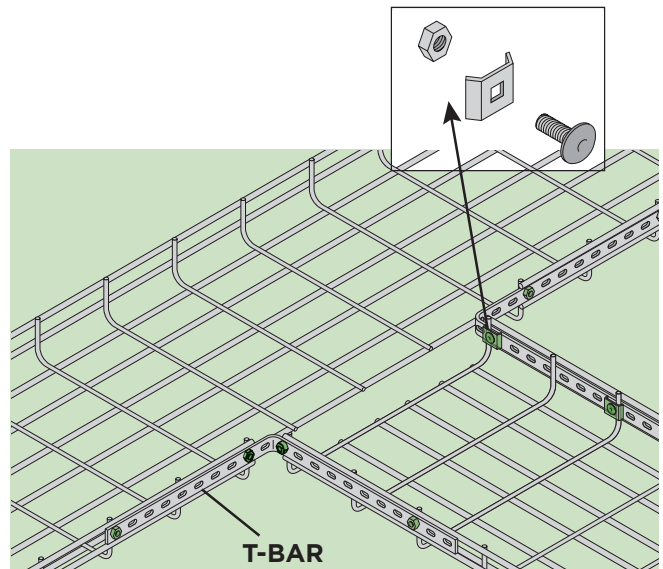
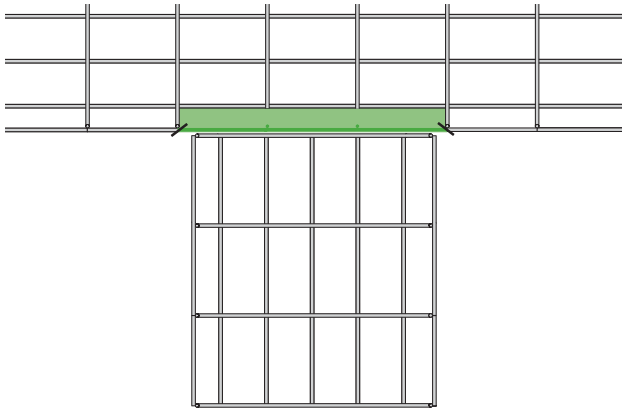
Fittings Overview / Assembly

Standard Tee & Cross

Standard Hardware Per Tee

- (1) T-BAR (cut in half) or (2) T-BAR-22
- (8) CH3

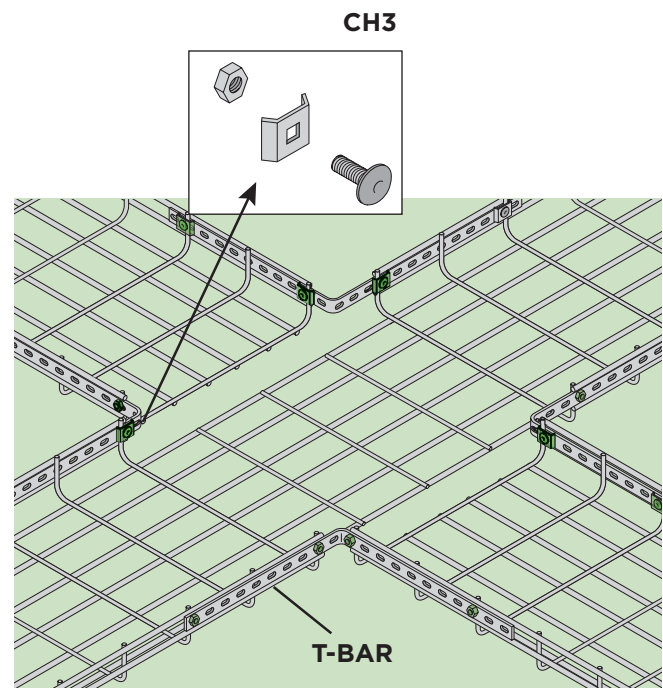
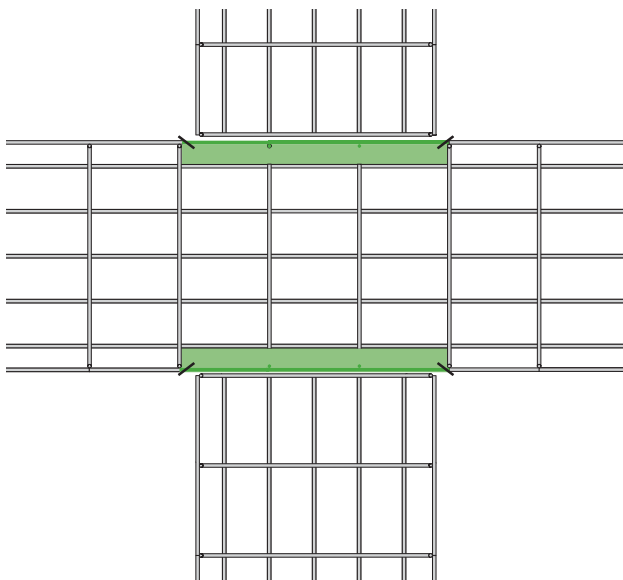
Note: Always place nut on outside of tray



Standard Hardware Per Cross

- (2) T-BAR (cut in half) or (4) T-BAR-22
- (16) CH3

Note: Always place nut on outside of tray



Eagle Basket

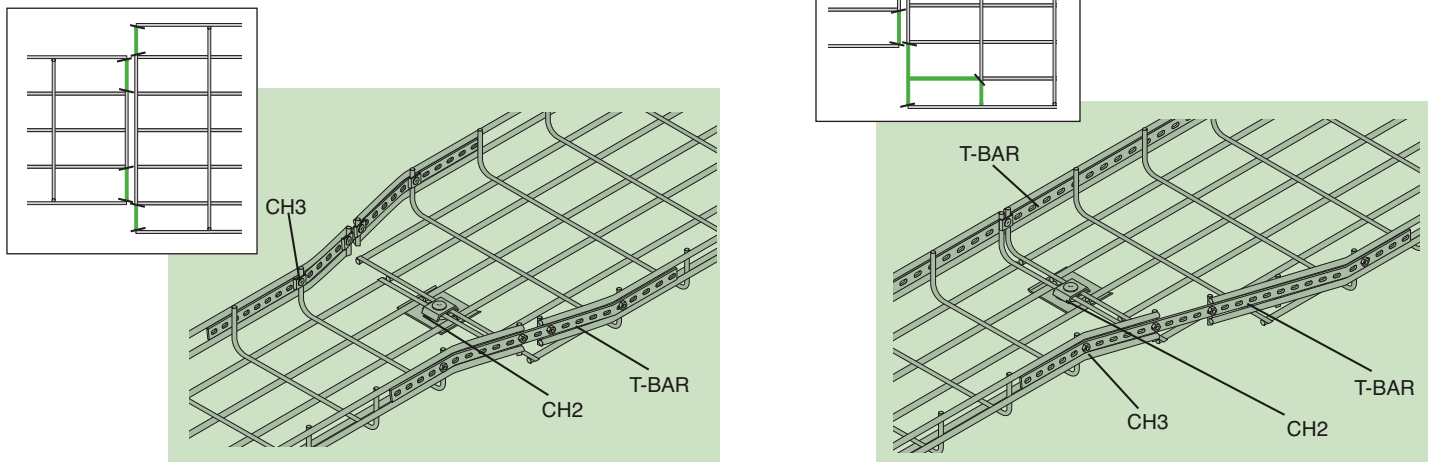
Fittings Overview / Assembly Reducers And Riser Fittings

Straight Reducer & Left/Right Reducer

Standard Hardware Per Reducer

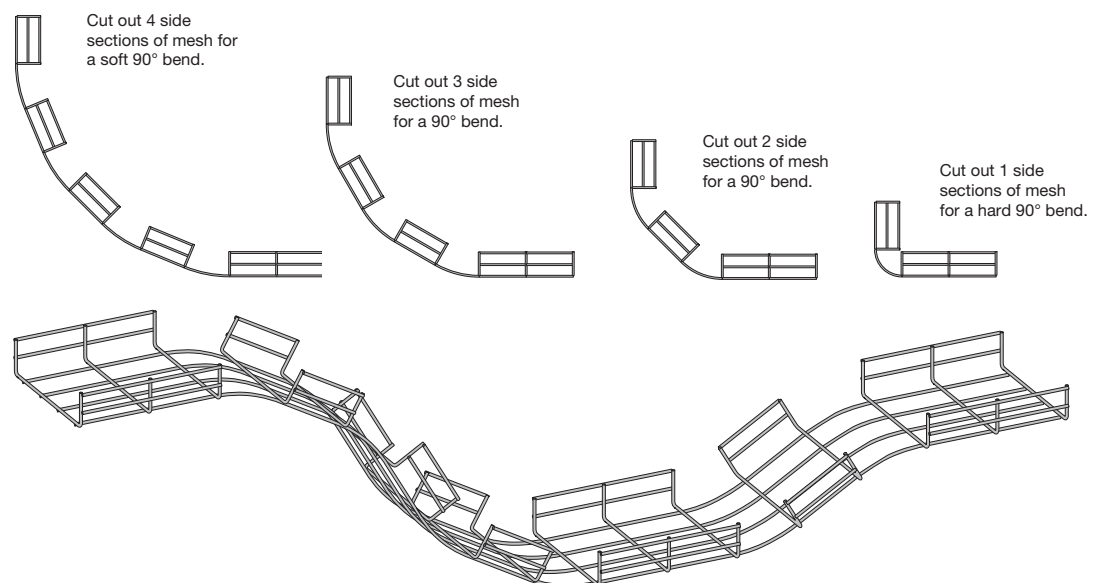
- (2) T-BAR
- (8) CH3
- (1) CH2

Note: Always place nut on outside of tray

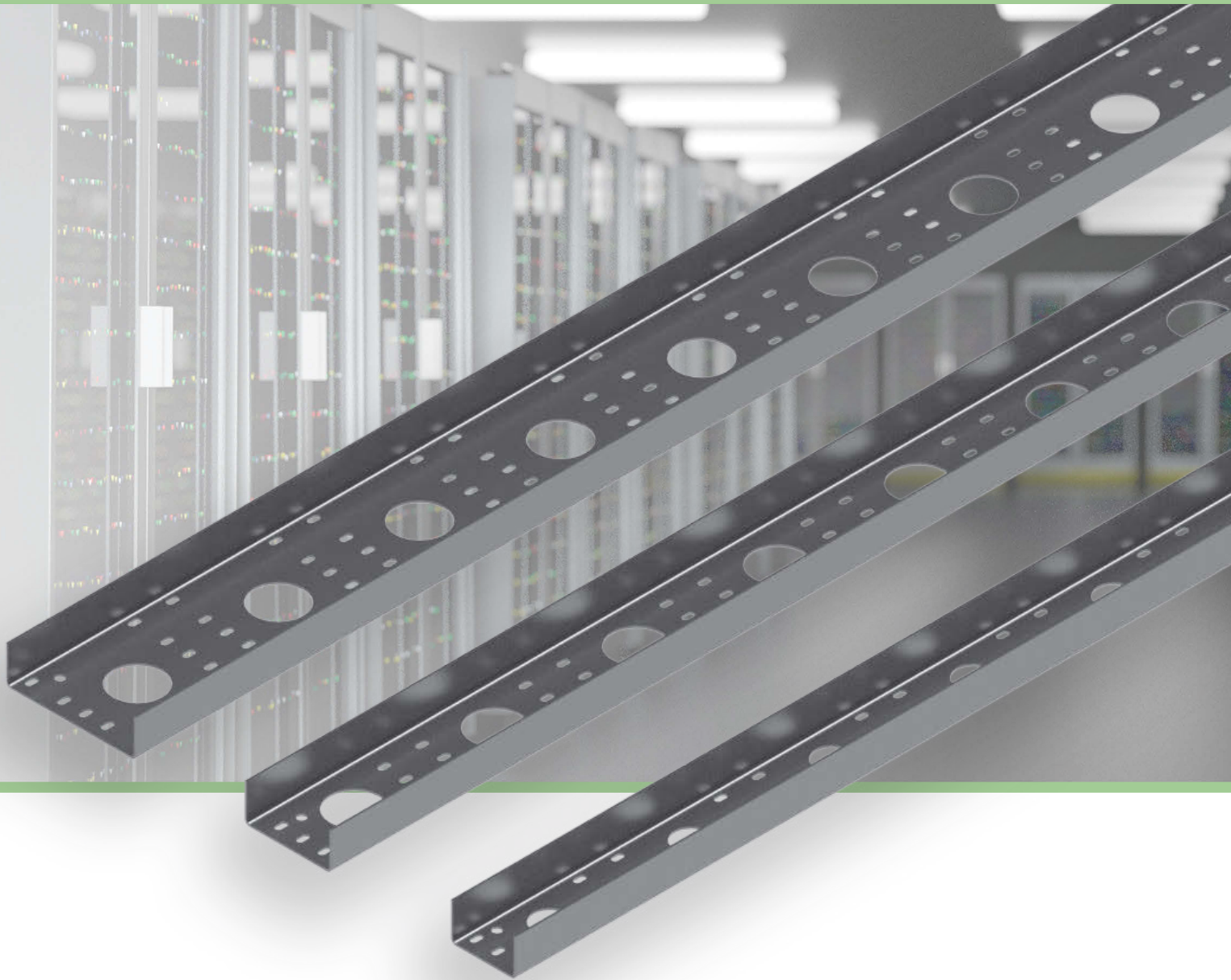


Riser

Risers and drops can be created to avoid different obstacles in the basket path. Simply cut the required number of side mesh sections and bend a vertical riser or drop to fit the application.



CHANNEL



**Cable Tray for Branch Power Circuits,
Control, Signal & Tubing Systems**



Contents

General & Technical Information

Pictorial Index159
Straight Lengths..... 160

Cope Channel Fittings

Horizontal Fittings.....161
Vertical Fittings.....161

Dividers

Straight, Horizontal, Vertical Dividers and Hardware.....162

Splices & Connectors

Standard, Expansion, Vertical Adjustable, Horizontal Adjustable, Reducing 163

Covers

Covers..... 164
Cover Accessories 164

Accessories

Support Clamps165
Mounting Brackets, Strut Brackets, Wall Brackets, Double Hanger165
Floor Base Plate, Blind End165

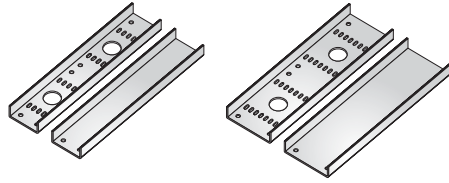


Pictorial Index

Pictorial Index

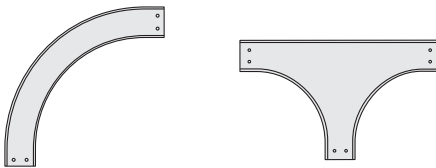
Straight Length

Page 160



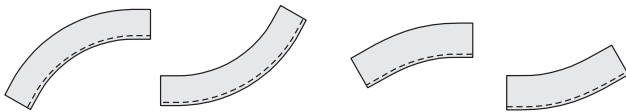
Horizontal Fittings

Page 161



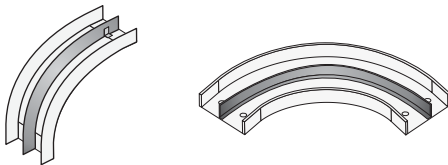
Vertical Fittings

Page 161



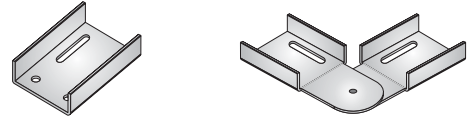
Dividers

Page 162



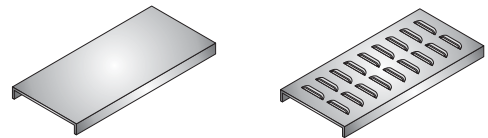
Splices & Connectors

Page 163



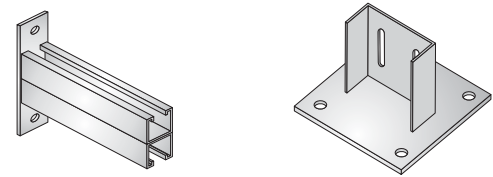
Covers

Page 164



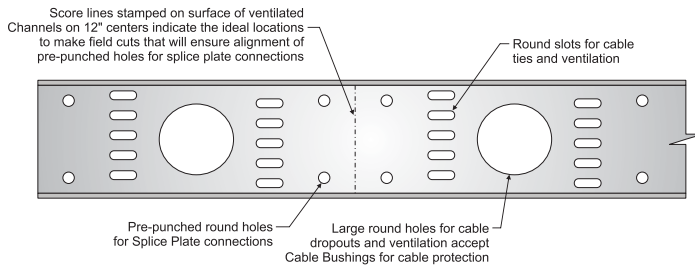
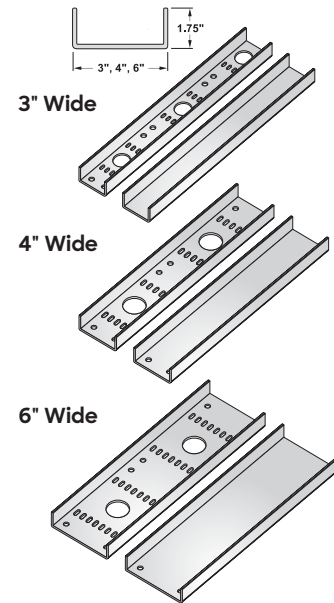
Accessories

Page 165



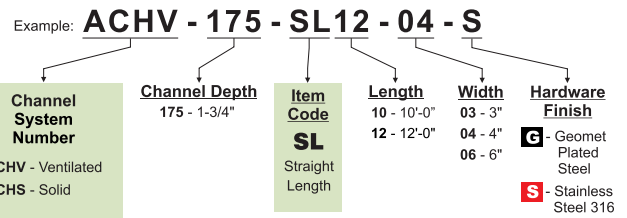
Cable Channel Straight Sections - Aluminum

- Extruded aluminum alloy 6063-T6
- Ventilated and Solid designs
- Ventilated have large holes for cable drops and slots for cable ties
- Ventilated have holes for splice plates that repeat on 12" centers to simplify field modifications
- UL Classified grounding
- UL Certified load capacities
- NEMA, CSA and NEC Compliant
- Necessary Splice Plates with hardware are included with all straight sections and fittings
- **Channel is also available in steel - Contact Factory Representative**



Channel Hole Pattern Details (Pattern Repeats on 12" Centers)

Catalog Numbers for Straight Channel Sections



Cable Channel Straight Sections							Safe Load Data (lbs/ft), 1.5 Safety Factor				
Width	Depth	Design	System Number	Standard Length	UL Area (in ²)	AMP Rating	NEMA Load Class	Support Span			
								6'	8'	10'	12'
3"	1.75"	Solid	ACHS	12'	0.40	600	5A	40	22	14	10
		Ventilated	ACHV	12'	0.40	600	5A	40	22	14	10
4"	1.75"	Solid	ACHS	12'	0.60	1000	8AA	48	27	17	12
		Ventilated	ACHV	12'	0.40	600	8AA	48	27	17	12
6"	1.75"	Solid	ACHS	12'	0.60	1000	8AA	48	27	17	12
		Ventilated	ACHV	12'	0.60	1000	8AA	48	27	17	12

Cable Bushing

- Provides protection for cables
- Snaps into large holes in ventilated channels
- Black plastic

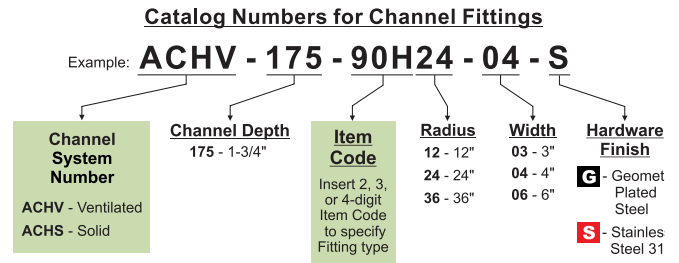


Channel Width (in)	Catalog No. (each)
3	SB-P-1.25
4 & 6	SB-P-2

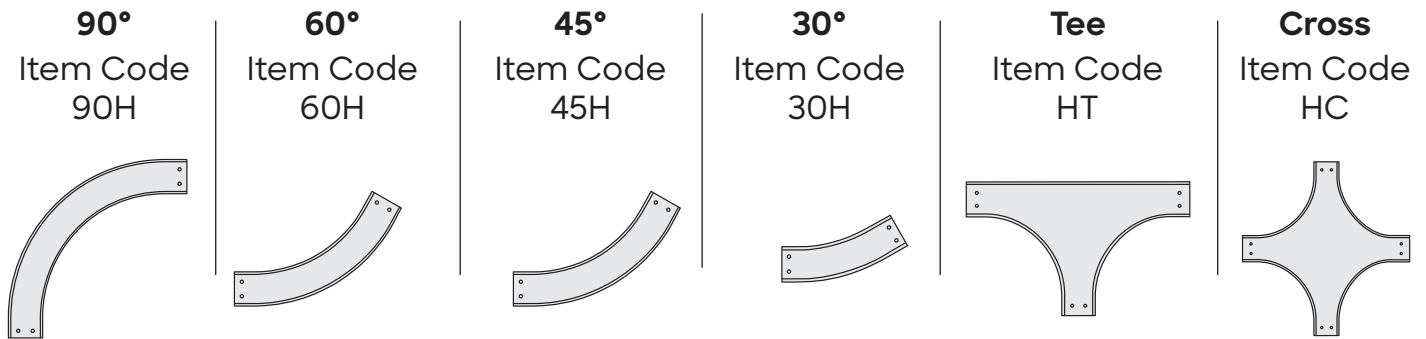


Channel Fittings

- Material: All channel fittings are aluminum alloy 5052 with arc-welded construction
- Channel Bottoms: Fittings are available in solid and ventilated designs
- Tangents: All fittings have 3" tangents (flats) at the end of all curved side rails to accommodate splice plate connectors
- Radius: Standard 12", 24" and 36" radius are available for all fittings. 48" radius and other custom designs are also available, consult factory
- Splice Plates: All elbows are supplied with one standard splice plate with hardware at no charge. Tee fittings include 2 connectors and crosses include 3 connectors with hardware at no charge



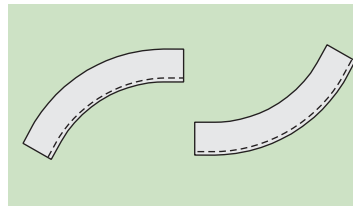
Horizontal Channel Fittings



Vertical Channel Fittings

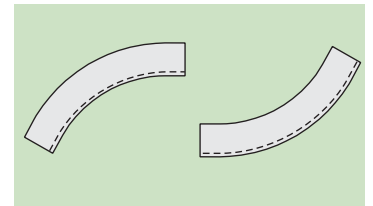
90° Outside
Item Code 90VO

90° Inside
Item Code 90VI



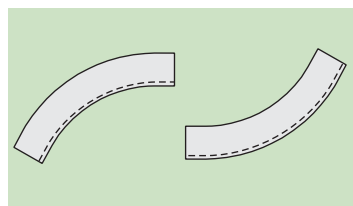
45° Outside
Item Code 45VO

45° Inside
Item Code 45VI



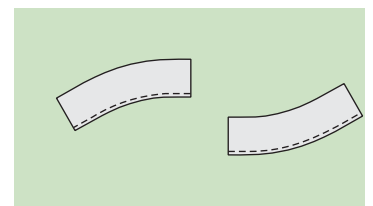
60° Outside
Item Code 60VO

60° Inside
Item Code 60VI



30° Outside
Item Code 30VO

30° Inside
Item Code 30VI

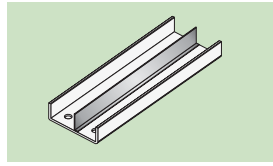




Channel Dividers

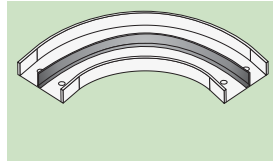
Straight

- Supplied with (4) #10 self-drilling, stainless steel screws



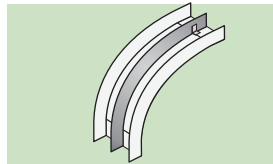
Horizontal Flexible

- Supplied with (3) #10 self-drilling, stainless steel screws



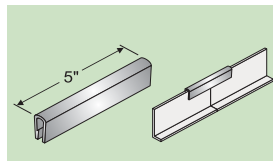
Vertical Elbow

- Supplied with (2) #10 self-drilling, stainless steel screws



Divider Splice

- Flexible PVC with internal metal clips
- Align and protect divider ends



Straight & Flexible Catalog Numbers:

Example: **DSC-A175-12**

Item Code	Channel Height	Length
DSC - Straight	175 - 1-3/4"	Straight Sections: 10 - 10' 12 - 12'
DHC - Horizontal Flexible		Horizontal Flexible: 6 - 6'

Vertical Elbow Divider Catalog Numbers:

Example: **DFC-A175-45VO24**

Item Code	Channel Height	Elbow Item Code	Radius
DFC Vertical Elbow	175 - 1-3/4"	90VO - 90° Vertical Outside 90VI - 90° Vertical Inside 60VO - 60° Vertical Outside 60VI - 60° Vertical Inside 45VO - 45° Vertical Outside 45VI - 45° Vertical Inside 30VO - 30° Vertical Outside 30VI - 30° Vertical Inside	12 - 12" 24 - 24" 36 - 36"

Catalog No. (each)	Length
DVS-5	5"
DVS-(L)*	L* = inches

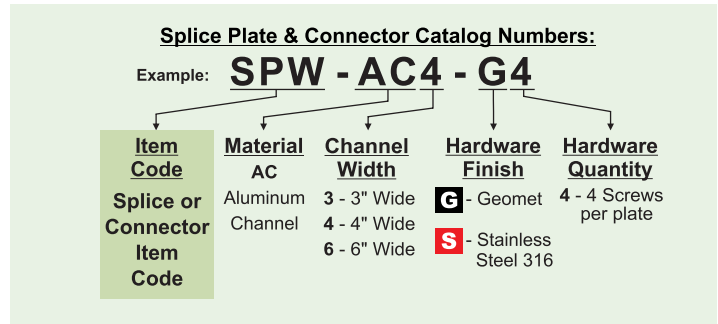


Channel Splices and Connectors

All Splice Plates for Channel are supplied in single units, not in pairs. Geomet-plated steel hardware is supplied with all splices and connectors. Type 316 stainless steel hardware is optional.

Standard Splice Plates are automatically included with all straight Channel sections and fittings. Extras for field cuts or spares should be ordered separately.

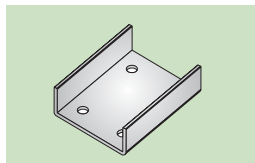
Bonding Jumpers are required for use only with expansion connectors and at discontinuities in the tray system. Bonding jumpers are not required for use with vertical or horizontal adjustable connectors.



Standard

Item Code

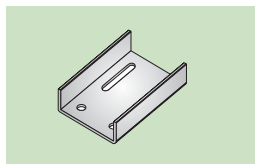
SPW



Expansion

Item Code

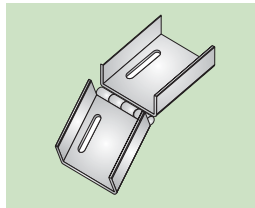
SPE



Vertical Adjustable

Item Code

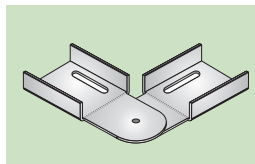
SPV



Horizontal Adjustable

Item Code

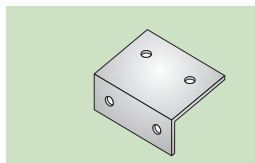
SPH



Box Connector

Item Code

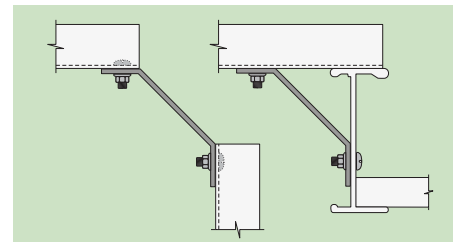
SPB



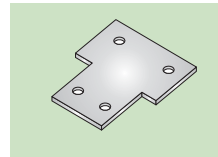
Channel-to-Channel & Tray-to-Channel

Item Code

CTC



Reducing Splices

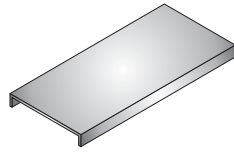


Channel Width	Catalog No. (each)
4" to 3"	SPR-AC43-(F)*4
6" to 3"	SPR-AC63-(F)*4
6" to 4"	SPR-AC64-(F)*4

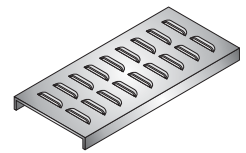
(F)* insert **G** or **S**

Channel Covers

Flat, Flanged, Solid
Item No. FFS



Flat, Flanged, Ventilated
Item No. FFV



Straight Cover Catalog Numbers:

Example: **ACC - FFS - SL12 - 04 - 040**

Material	Cover System	Item Code	Length	Width	Thickness
ACC Aluminum Channel Cover	FFS FFV	SL Straight Length	Standard: 10 - 10'-0" 12 - 12'-0" Non-standard lengths are available; consult factory for lead times	03 - 3" 04 - 4" 06 - 6"	040 - 0.040" (Standard) Alternates: 063 - 0.063" 080 - 0.080" 090 - 0.090" 125 - 0.125" 188 - 0.188"

Fitting Cover Catalog Numbers:

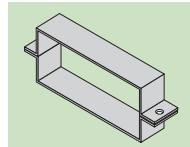
Example: **ACC - FFS - 90VO12 - 06 - 040**

Material	Cover System	Item Code	Radius	Width	Thickness
ACC Aluminum Channel Cover	FFS FFV	Fitting Item Code Page 159	12 - 12" 24 - 24" 36 - 36"	03 - 3" 04 - 4" 06 - 6"	Blank - 0.040" (Standard) Alternates: 063 - 0.063" 080 - 0.080" 090 - 0.090" 125 - 0.125" 188 - 0.188"

Cover Clamps

Flat Covers

- Aluminum with 1/4" Dia. Stainless Steel Fasteners
- Suitable for Outdoor and Vertical use

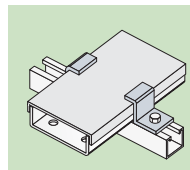


Width	Catalog No. (each)
3"	CFS-AC-03-S
4"	CFS-AC-04-S
6"	CFS-AC-06-S

Combination Cover Clamp & Hold-Down

- Hole sized for 1/2" fasteners
- Fasteners ordered separately

*Optional: For hole sized for 1/4" or 3/8" fasteners, insert catalog no. suffix -14 or -38

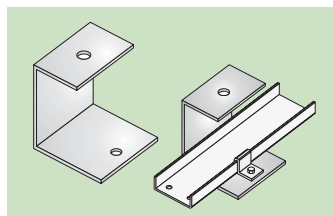


Catalog No. (each)
HDC - AC

Channel Accessories

Single Hanger & Wall Bracket

- Aluminum
- Fasteners, clamps and rods Not Included



Width	Catalog No. (each)
3" & 4"	ACHS-A-03-04
6"	ACHS-A-06



Channel

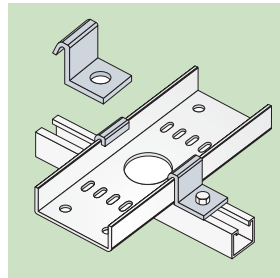
Channel Accessories

Support Clamps

- Hole sized for 1/2" fasteners
- Fasteners ordered separately

*Optional: For hole sized for 1/4" or 3/8" fasteners, insert catalog no. suffix -14 or -38

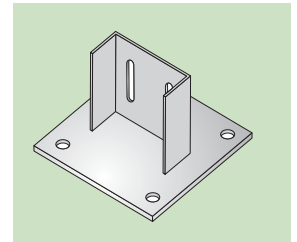
Clamp Type	Catalog No. (each)
Hold Down Clamp	HDZ-AC
Expansion Guide Clamp	HDE-AC



Floor Base Plate

- Aluminum
- Fasteners Included for Channel attachment only

Width	Catalog No. (each)
3"	CFB-AC3-(F)*
4"	CFB-AC4-(F)*
6"	CFB-AC6-(F)*



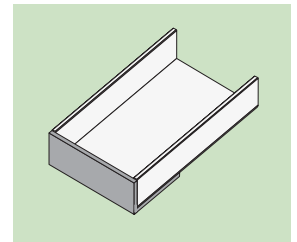
(F)* insert Fastener Materials

- G** Steel, Geomet Plated or
- S** Stainless Steel, Type 316

Blind End

- Aluminum
- Fasteners Included

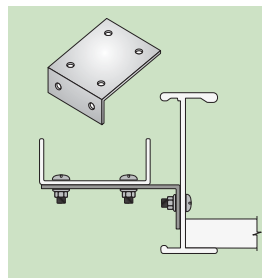
Width	Catalog No. (each)
3"	BE-AC3-(F)*
4"	BE-AC4-(F)*
6"	BE-AC6-(F)*



Mounting Bracket

- Aluminum
- Fasteners Included

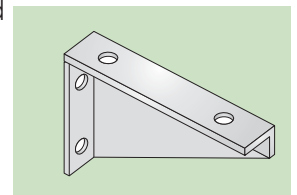
Width	Catalog No. (each)
3"	CMB-AC3-(F)*
4"	CMB-AC4-(F)*
6"	CMB-AC6-(F)*



Wall Bracket

- Aluminum
- 8" Wide for 3" & 4" Channels
- 10" Wide for 6" Channels
- No Fasteners Included

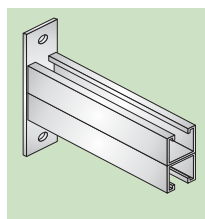
Width	Catalog No. (each)
3" & 4"	WBC-A-08
6"	WBC-A-10



Strut Bracket

- Aluminum
- 8" Wide for 3" & 4" Channels
- 10" Wide for 6" Channels
- No Fasteners Included

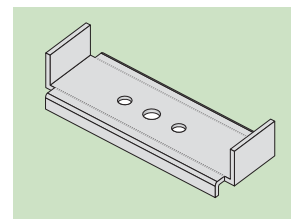
Width	Catalog No. (each)
3" & 4"	WBSC-A-08
6"	WBSC-A-10



Double Hanger

- Aluminum
- Hang from 1/2" Threaded Rod
- Fasteners, Clamps and Rods Not Included

Width	Catalog No. (each)
3"	ACHD-A-03
4"	ACHD-A-04
6"	ACHD-A-06





Fiberglass Cable Tray and Channel



**Cable Tray for Corrosive
and Adverse Environments**



Contents

General & Technical Information

Pictorial Index 169
 Advantages of Cope-GLAS™ Cable Tray171
 Fiberglass Cable Tray Standards173
 Cope-GLAS™ Cable Tray Specifications..... 175

Cable Tray Design and Application

Construction and Physical Properties..... 176
 Application Environments.....178
 Cope-GLAS™ Structural Designs 180
 Cope-GLAS™ Selection Guide..... 181
 Installation Procedures.....182

Product Information

Straight Sections..... 189
 Covers..... 191
 Vertical Elbows (Inside and Outside)
 90°193
 45° 194
 Adjustable (VAB)195
 Vertical Tee..... 196
 Horizontal Elbows
 90°197
 45°197
 Adjustable (HAB)..... 198
 Horizontal Tee 199
 Horizontal Cross202
 Straight Reducers.....200
 Left and Right Hand Reducers200

Accessories

Splice Plates..... 201
 Accessories.....205
 Cope-GLAS™ Fiberglass Channel..... 209

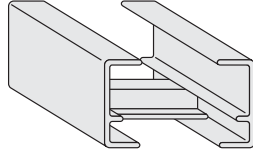


Fiberglass Cable Tray & Channel

Pictorial Index

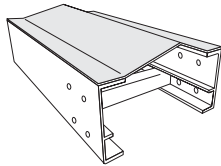
Straight Length

Page 189



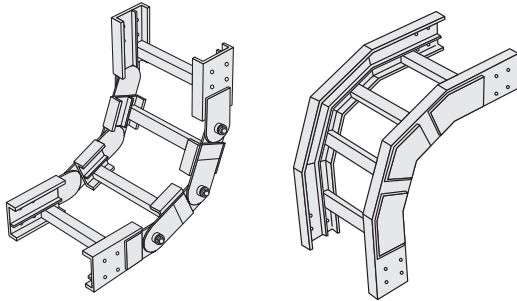
Covers

Page 191



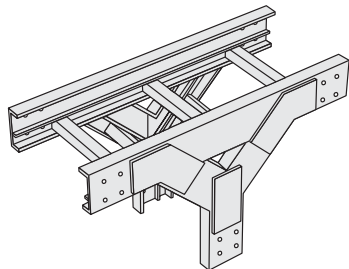
Vertical Bends (Inside & Outside)

Page 193



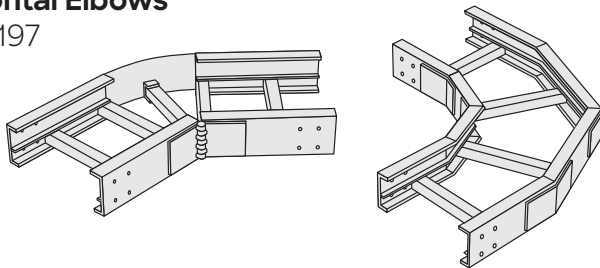
Vertical Tees

Page 196



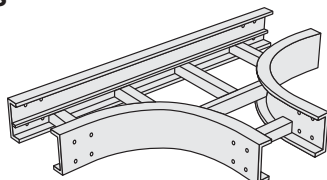
Horizontal Elbows

Page 197



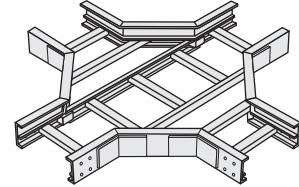
Horizontal Tees

Page 199



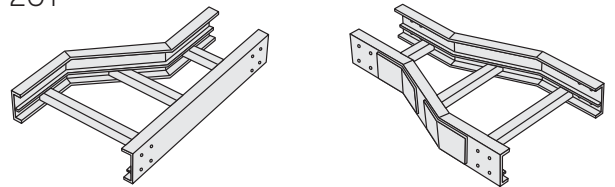
Horizontal Cross

Page 200



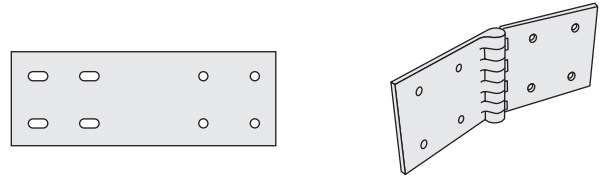
Reducers

Page 201



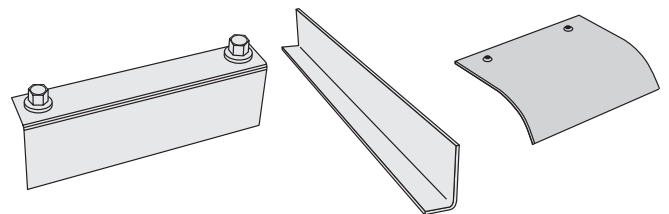
Splice Plates

Page 203



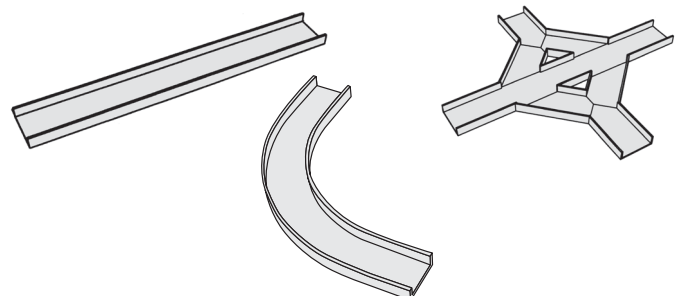
Accessories

Page 205



Cope Fiberglass Channel System

Page 209



Contents

Cope-GLAS Cable Tray is UL Listed

Cope-Glas Fiberglass Cable Tray as manufactured by Cope (a part of Atkore International) is now UL listed. This UL Listing guarantees the customer that they will receive a quality product that meets the rigid standards of Underwriters Laboratories. Furthermore, it ensures the customer that the product they receive will meet the required UL and NEMA FG1 performance criteria in the following areas:

- Low Temperature
- High Temperature
- Flame resistance
- Loading & Deflection
- Dielectric Strength
- Volume Resistivity
- Thermogravimetric Analysis
- Infrared Analysis
- UV Exposure
- Water Exposure & Erosion

In order to maintain the UL Listing, Cope must continually undergo follow-up testing with Underwriters Laboratories. This further assures the customer that Cope is maintaining its quality with respect to raw materials, production and fabrication. This UL Listing demonstrates Cope's commitment to developing and providing its customers with the highest quality fiberglass cable tray products available in the industry.



Fiberglass Cable Tray & Channel

Advantages of Cope-GLAS™ Cable Tray

Cope-GLAS™ Systems Advantages

Engineers, designers, contractors, installers and end users have many reasons to choose Cope-GLAS cable tray for their power, signal and control distribution support requirements. Here are some specific advantages that Cope-GLAS systems provide:

Corrosion Resistance

The inherent chemical resistance of Cope-GLAS cable tray makes it desirable for severely corrosive environments. Life cycle costs of tray installations can be dramatically reduced by the extended life expectancy of this product. Many original installations have been in service for nearly twenty-five years and are providing reliable service.

Versatile

Cope-GLAS cable tray systems are available in a variety of sizes and styles. A standard or special design can be fabricated for any indoor or outdoor application regardless of size.

Easy Installation

Cope-GLAS cable tray is strong and lightweight, allowing this durable system to be installed quickly and easily. Because there are no sharp edges or burrs, long runs of armored cable can be installed with less chance for cable damage.

Tray System Advantages Over Other Wiring Methods

Cable tray systems in general provide the following advantages over other wiring methods:

Full Ventilation

Power cables need not be directed in a ventilated cable tray system. Explosive gases cannot be trapped or transmitted as in totally enclosed wiring systems.

Long Support Spans

Cope-GLAS cable tray systems are designed for up to twenty foot support spans, longer than most other wiring methods. Fewer supports reduce both installation time and cost.

Installation Labor Reduced

Cope-GLAS cable tray can be installed after concrete and major building steel and mechanical piping are complete. Crews can start later and finish sooner.

Space Efficiency

Cope-GLAS cable tray systems can carry more cable in less space than other wiring methods.

Fully Compatible with other Wiring Methods

Cope-GLAS cable tray is often used in main runs when other wiring methods are employed in branch circuits.

Simple Field Modifications

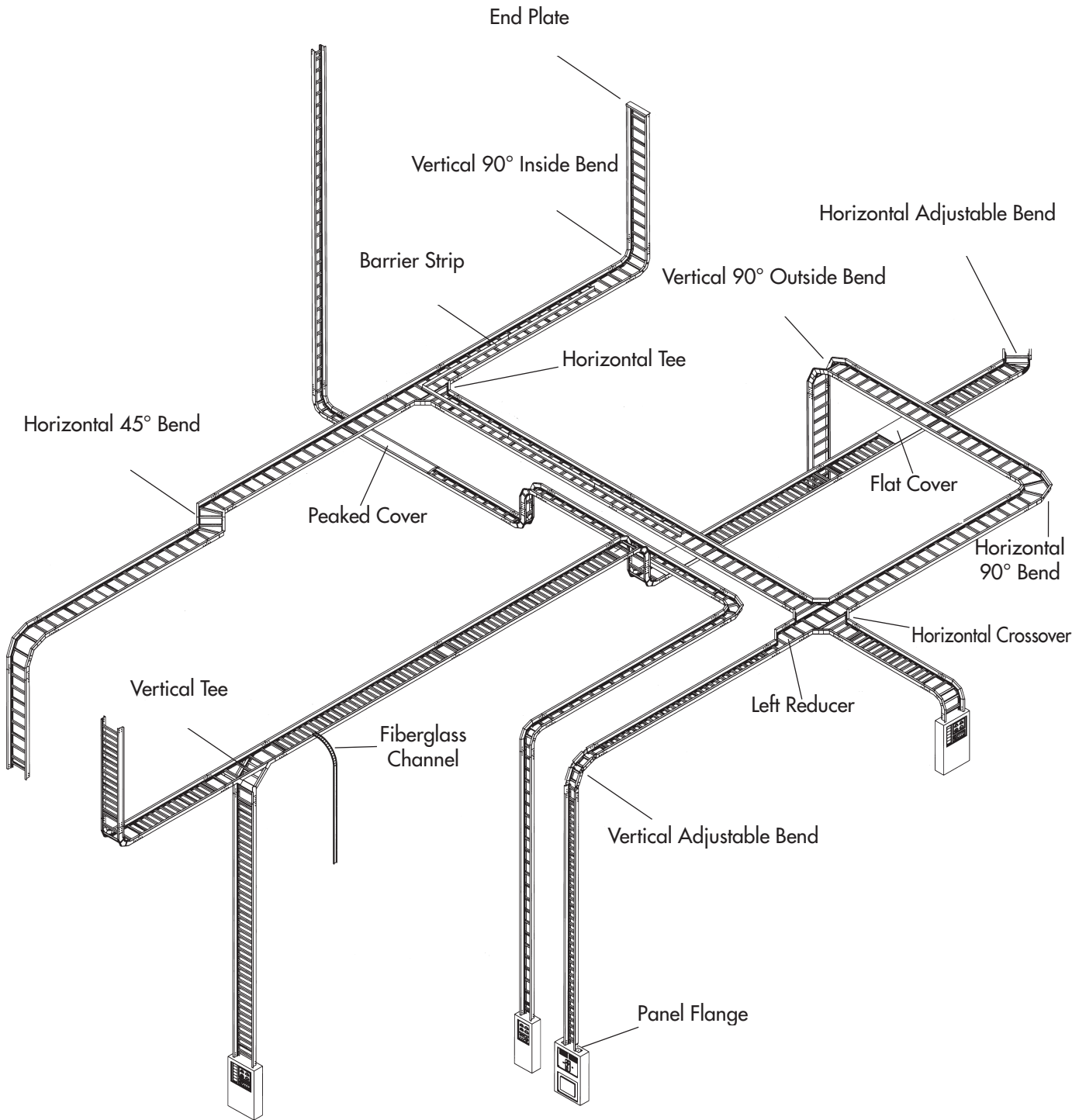
Modifications can be made easily using standard metalworking tools without extensive re-engineering.

Accessibility for the Future

New cable can be easily added, replaced or repaired. Circuits can be visually traced, minimizing startup and trouble shooting.

Advantages of Cope-GLAS™ Cable Tray

Example Components



Fiberglass Cable Tray & Channel

Standards

The standards commonly referenced in specifying cable tray are the National Electric Code®, Article 392-Cable trays; NEMA Standards Publication NO. FG 1, Fiberglass Cable Tray Systems; Canadian Standards Association CAN/CSA-C22.2 No. 126-M91, Cable Tray Systems and Underwriters Laboratories Inc. Standard UL-568, CYOV Non-Metallic Cable Trays. ASTM and UL standards are also referenced to characterize the materials used to construct the fiberglass cable tray.

ASTM standards define physical properties tests for the materials used to pultrude the cable tray. The specific ASTM test methods for mechanical, thermal and flammable properties are identified in the Construction and Physical Properties Section. UL flammability standards applied to fiberglass cable tray materials are also identified in the same section. ASTM and UL standard material properties for fiberglass channel and strut are identical to those of the cable tray because they are pultruded from the same materials.

Load Standards

Section 3 of NEMA FG 1 provides the performance standards and class designations for fiberglass cable tray systems. Based on a twenty foot support span, three working load classifications are recognized:

Cope-GLAS "Z" Style is available in one load classification. The deep tray, which provides six inches of cable fill depth, is designated as type CZD for its respective NEMA class. The "E" Style tray is available in two load classes, which are designated as type BE and type CE for the respective NEMA classes. All Cope-GLAS tray styles have a 1.5 safety factor and exceed the NEMA FG 1 requirement for the allowable working load.

Load Standards

Load Class	Allowable Working Load
A	50 lbs./linear ft.
B	75 lbs./linear ft.
C	100 lbs./linear ft.

The Low Profile Cable Tray, type LC, is not yet included in the NEMA Standard; however, it has been designed and tested to comply with the intent of NEMA FG 1. A safety factor 1.5 times the type LC working load of 50 lbs./linear foot for a 12 foot length has been confirmed by NEMA FG 1 test methods.

Type LC cable tray meets the requirements of Class C1 in the CAN/CSA-C22.2 No. 126-M91 standard.

Considerations for Cable Tray Deflection

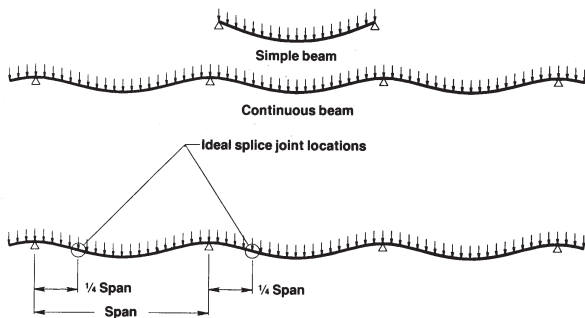
Cable Tray load testing as specified by NEMA Standard FG 1 requires the test article to be a single length of tray simply supported at each end (referred to as a simple beam configuration - see diagram next page). This requirement was established to standardize testing and because it is impractical to test large tray system assemblies to destruction. Most actual tray installations consist of multiple lengths of connected tray with multiple supports (referred to as a continuous beam configuration). The most significant difference between a continuous versus simple beam configuration is that for continuous beam, the presence of adjacent lengths of tray affect the deflection of the tray in the section of interest.

With the same loading and support span, the maximum deflection is dramatically less for continuous compared to simple beam. For example, in the NEMA FG 1 simple beam test, Cope-GLAS Class CE fiberglass cable tray deflects approximately 3.75" at the mid-point of a 20' support span while carrying its rated load of 100 pounds per foot. In continuous beam, the maximum mid-span deflection would be only 0.8" or 20% of that for simple beam.

Standards

Tray Splice Joint Locations vs. Support Locations

In a continuous beam configuration, the bending moment in the tray side rails becomes zero at points located approximately $\frac{1}{4}$ of the span from each tray support (referred to as quarter span points or just quarter points). For example, if the support span is 10', the quarter point is 2.5' from the support. Quarter points are ideal locations for spliced tray connections because joints are subjected to minimum bending stresses (see diagram below).



Effect of Temperature

When continuously exposed to elevated temperatures, the strength properties of reinforced fiberglass are reduced. Working loads shall be reduced based on the following table.

Chemical Resistance

Fiberglass is used because of its superior corrosion resistance; therefore, corrosion resistance data for specific environments are very important. The corrosion resistance guide in the Application Environments Section offers performance data in the most common environments. If information for a specific environment is not shown in the guide, please consult the factory.

Installation/Application

Guidance for cable tray installation, supports and support locations, and thermal expansion/contraction is provided in NEMA FG 1. The installation instructions for supports and support locations contained in the Installation Procedures Section of this catalog are based on the Application Information Section of NEMA FG 1.

Effect of Temperature

Temp. in °F	Approximate % of Strength	
	Polyester Resin	Vinyl Ester Resin
75°	100	100
100°	90	100
125°	78	100
150°	68	90
175°	60	90
200°	52	75

Note: Consult the manufacturer when temperatures above 200° F are encountered. Cope-GlasTM is not adversely affected by below freezing temperatures.



Fiberglass Cable Tray & Channel

Specifications

Cope-GLAS™ Cable Tray System

1. Material

1.1 Cable tray shall be of pultruded glass reinforced polyester or vinyl ester resin having physical property values as listed in the Design and Application Section of this catalog.

2. Composition

2.1 Glass reinforced components shall have a synthetic NEXUS® veil applied on exterior surfaces to improve weatherability and inhibit ultraviolet degradation.* An ultraviolet stabilizer shall be incorporated in the resin formulation to further inhibit ultraviolet degradation.

3. Structural Design

3.1 Cable tray shall be of ladder type design having "E" or "Z" shaped side rails.

3.2 Rungs shall be of the same material as the side rail and shall be secured in place to prevent roll-over when cables are pulled into the tray.

3.3 Cable tray sections shall be 10' or 20' in length (+ or - 1/8"). Each straight section and fitting shall be furnished with pre-punched holes to accept the splice plate fastener.

3.4 Tray system design shall meet or exceed allowable working loads in accordance with the appropriate standard, i.e. NEMA FG 1, CAN/CSA-22.2 No. 126-M91 or UL-568.

3.5 Cable trays shall exceed NEMA FG 1 load requirements.

3.6 The tray loaded to the allowable working load shall be capable of supporting an additional 200 lb. concentrated static load at mid-span without failure or permanent deflection.

3.7 Tray system design shall meet all the requirements set forth in Underwriters Laboratories Fiberglass Cable Tray Standard, UL-568. The tray system design shall be tested by UL and be issued the appropriate certified UL listing.

*Due to process limitations, compression molded parts do not incorporate surface veil.

4. General

4.1 Cable trays shall be furnished as a system including all necessary fasteners, hold-down clips, splice plates, support systems, barrier strips, covers, hinged horizontal and vertical splice plates, elbows, reducers, tees, crosses, etc.

4.2 Standard cable tray fittings shall be assembled by the manufacturer. Adjustable fittings may require some field adjustment.

4.3 Splice plate fasteners shall be fiberglass encapsulated stainless steel. Fasteners shall be designed to prevent encroachment of liquids or vapors on the metal threads when fully assembled and tightened. Fasteners must be capable of withstanding a torque of 10 ft.-lbs. without damage to the threads of encapsulated coating.

4.4 Manufacturer shall provide certified test data to verify compliance with above loading and deflection data when requested by the purchaser.

4.5 Witness tests may be specified by the customer and shall be scheduled at the time of purchase. Documentation shall also be specified at the time of purchase.

4.6 Special non-standard tests, if requested, shall be specified at the time of purchase.

Construction and Physical Properties

The Pultrusion Process

The pultruded structural component is made by reinforcing a polymer resin (usually polyester or vinyl ester resin) with multiple strands of glass filament and alternating layers of glass mat.

The glass is drawn through the liquid resin, which coats and saturates the fibers. The combination of resin and glass is then continuously guided and pulled (pultruded) through a heated die that determines the shape of the component.

In the die, the resin is cured to form a permanent, reinforced part which can be cut to a specific length. Since the hardened fiberglass pultrusion is reinforced with an internal arrangement of permanently bonded continuous glass fibers, it possesses great strength. In addition to strength, pultruded fiberglass components exhibit exceptional corrosion resistance. This attribute makes fiberglass the material of choice for many harsh industrial applications.

Resin Systems

Polyester and vinyl ester resin systems are available. The vinyl ester resin system is somewhat stronger and is applied in severe corrosive applications.

Both resin systems are flame retardant, conforming to ASTM E84, Class 1 flame rating and are self extinguishing per the requirements of UL94V-0.

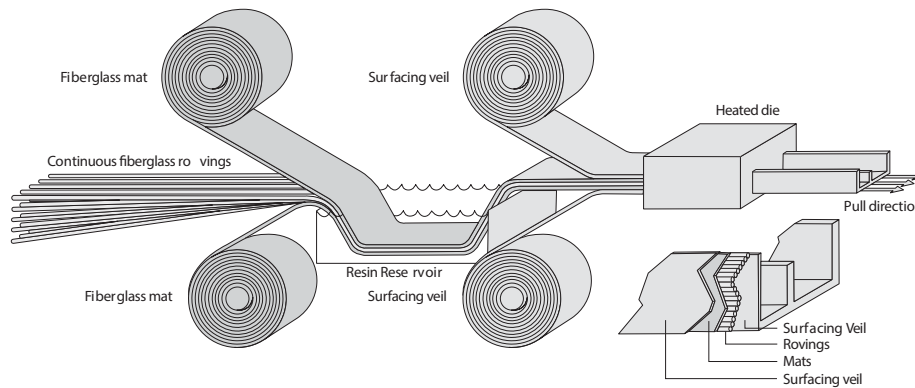
Consult the corrosion resistance guide on pages 178-179 to determine the correct resin system for your application.

Typical Properties	Typical Value Test Method	Typical Value Direction	Unit	Polyester	Vinyl Ester
Mechanical					
Ultimate Tensile Strength	ASTM D-638	Longitudinal	PSI	30,000	35,000
	ASTM D-638	Transverse	PSI	7,000	10,000
Tensile Modulus	ASTM D-638	Longitudinal	PSI	2.5 x 10 ⁶	3.0 x 10 ⁶
	ASTM D-638	Transverse	PSI	0.8 x 10 ⁶	1.0 x 10 ⁶
Ultimate Compressive Strength	ASTM D-695	Longitudinal	PSI	30,000	35,000
	ASTM D-695	Transverse	PSI	15,000	20,000
Compressive Modulus	ASTM D-695	Longitudinal	PSI	2.5 x 10 ⁶	2.5 x 10 ⁶
	ASTM D-695	Transverse	PSI	1.0 x 10 ⁶	1.2 x 10 ⁶
Ultimate Flexural Strength	ASTM D-790	Longitudinal	PSI	30,000	35,000
	ASTM D-790	Transverse	PSI	10,000	14,000
Flexural Modulus	ASTM D-790	Longitudinal	PSI	1.6 x 10 ⁶	2.0 x 10 ⁶
	ASTM D-790	Transverse	PSI	0.8 x 10 ⁶	1.0 x 10 ⁶
Shear Strength Short Beam	ASTM D-2344	Longitudinal or	PSI	5,500	7,000
		Transverse	PSI	5,500	6,000
Impact Strength-Izod	ASTM D-256	Longitudinal	ft.-lb./in.	25	30
		Transverse	ft.-lb./in.	4	5
Hardness-Barcol	ASTM D-2583	Perpendicular		50	50
Electrical					
Electric Strength Short Time-in oil	ASTM D-149	Perpendicular	Volts/mil.	200	200
		Parallel	KV/in.	35	35
Dielectric Constant	ASTM D-150	Perpendicular	F/M	5.0	5.0
Dissipation Factor	ASTM D-150	Perpendicular		0.03	0.03
Arc Resistance	ASTM D-495	Longitudinal or	Seconds	80	120
		Transverse	Seconds	80	120



Fiberglass Cable Tray & Channel

Construction and Physical Properties



Cope-GLAS Material Properties (Continued from previous page)

Glass Roving and Mat Reinforced Polyester and Vinyl Ester Fiberglass Components

Typical Properties	Typical Value	Direction	Typical Value		
			Test Method	Unit	Polyester
Other	ASTM D-696	Longitudinal	in./in./°F	5" x 10 ⁻⁶	5" x 10 ⁻⁶
Thermal Coefficient of Expansion		Longitudinal	BTU/Hr. sq. ft./in./°F	4	4
Thermal Conductivity		Longitudinal	%	1	1
Water Absorption 24 hours	ASTM 0-570	Longitudinal	lbs./cu.in.	0.062	0.062
Density	ASTM D-792	Longitudinal	Classification:	Dark Gray	Beige
Color (Standard)	UL94		Rating:	V-0	V-0
Flammability	ASTME84			25	25

The foregoing list of properties was derived from laboratory data using coupon test specimens cut from pultruded sections. Such information should only be used as a general guide in design. Many actual components (such as cable tray side rail) take advantage of the flexibility of the pultrusion process and are selectively reinforced to enhance performance in a particular load axis. The factory should be contacted for specific information on any given component.

Aickinstrut Fiberglass Threaded Rod Material Properties Threaded rod is a proprietary combination of fiberglass and Class I vinyl ester flame retardant resin.

Aickinstrut Fiberglass Threaded Rod Material Properties

Threaded rod is a proprietary combination of fiberglass and Class I vinyl ester flame retardant resin.			
Properties	¾" -16 UNC	½" -13 UNC	⅝" -11 UNC
Thread shear strength using fiberglass nut in tensile (lbs.)	1,250	2,500	3,800
Transverse shear on threaded rod-double shear ASTM-B-565 (load lb.)	4,200	7,400	11,600
Transverse shear on threaded rod-single shear (load lb.)	1,600	2,600	3,800
Compressive strength-longitudinal ASTM-D-695 (psi)	55,000	55,000	55,000
Flexural strength ASTM-D-790 (psi)	60,000	60,000	60,000
Flexural modulus ASTM-D-790 (psi x 10 ⁶)	2.0 x 10 ⁶	2.0 x 10 ⁶	2.0 x 10 ⁶
Torque strength using fiberglass nut lubricated with SAE IOW30 motor oil (ft.-lbs.)	8	15	33
Dielectric strength ASTM-D-149 (kv/in.)	40	40	40
Water absorption 24 hour immersion-threaded ASTM-D-570 (%)	1	1	1
Coefficient of thermal expansion-longitudinal (in./in./°F)	5 x 10 ⁻⁶	5 x 10 ⁻⁶	5 x 10 ⁻⁶
Max recommended operation temp, based on 50% retention of ultimate thread shear strength (°F)	200	200	200
Stud weight (lb./ft.)	.076	.129	.209
Flammability	Self extinguishing per UL94V-0		

Application Environments

Corrosion Resistance

In most applications Cope-GLAS cable tray is used because of its superior corrosion resistance. The following corrosion resistance guide offers performance recommendations for the most common environments.

Additional data for less common environments are also available from the factory.

Corrosion Resistance Guide

The general guidelines presented in this table take into consideration the normal applications of cable tray products and accessories where exposure to harsh chemicals is limited to fumes or vapors and occasional splashes at ambient temperatures. This information is provided as a guide only since it is impossible to anticipate every conceivable application. For specific applications, which may fall out of the scope of these guidelines, it is recommended that the factory be consulted directly.

Special applications may require a screening test of material samples in the chemical environment of interest.

Notes:

S - indicates satisfactory performance.

NR - indicates not recommended for use. However, acceptable performance may be provided if fumes are not highly concentrated.

NA - indicates information not available.

Chemical Environment	Cope-GLAS Performance		Chemical Environment	Cope-GLAS Performance	
	Polyester	Vinyl Ester		Polyester	Vinyl Ester
Acetic Acid	S	S	Chlorinated Paraffin	S	S
Acetone	NR	NR	Chlorine, dry gas	S	S
Acrylic Acid	NR	S	Chlorine, wet gas	NR	S
Aluminum Chloride	S	S	Chlorine, liquid	NR	NR
Aluminum Chlorohydroxide	S	S	Chlorine Dioxide	NR	S
Aluminum Citrate	S	S	Chlorine Water	S	S
Aluminum Hydroxide	S	S	Chlorobenzene	NR	NR
Aluminum Nitrate	S	S	Chromic Acid	NR	S
Aluminum Potassium Sulfate	S	S	Chromous Sulfate	S	S
Aluminum Sulfate	S	S	Citric Acid	S	S
Ammonia, dry gas	S	S	Coconut Oil	S	S
Ammonia, liquid	NR	NR	Copper Acetate	S	S
Ammonium Acetate	NR	S	Copper Chloride	S	S
Ammonium Carbonate	NR	S	Copper Cyanide	S	S
Ammonium Chloride	S	S	Copper Nitrate	S	S
Ammonium Citrate	S	S	Copper Sulfate	S	S
Ammonium Hydroxide	NR	S	Cresylic Acid Fumes	NR	NR
Ammonium Nitrate	S	S	Cresol	NR	NA
Ammonium Phosphate	S	S	Crude Oil (Sour)	S	S
Ammonium Sulfate	S	S	Cyclohexane	NR	S
Ammonium Sulfide	NR	NA	Diallylphthalate	S	S
Ammonium Sulfite	NR	S	Diammonium Phosphate	NR	S
Ammonium Thiosulfate	NR	S	Dibutyl Ether	NR	S
Amyl Acetate	NR	NR	Dibutyl Phthalate	S	S
Amyl Alcohol	S	S	Diesel Fuel	S	S
Amyl Chloride	NR	NA	Diethylene Glycol	S	S
Aniline Sulfate	S	S	Dimethyl Phthalate	NR	S
Barium Acetate	S	S	Dimethyl Sulfoxide	NR	NA
Barium Carbonate	S	S	Diphenyl Ether	NR	S
Barium Chloride	S	S	Dipropylene Glycol	S	S
Barium Sulfate	S	S	Esters, Fatty Acid	S	S
Benzene	S	NR	Ethyl Alcohol	NR	S
Benzoic Acid	S	S	Ethylene Chlorohydrin	NR	S
Benzyl Alcohol	NR	NR	Ethylene Glycol	S	S
Borax	S	S	Fatty Acids	S	S
Boric Acid	S	S	Ferric Chloride	S	S
Brine	S	S	Ferric Nitrate	S	S
Bromine, dry gas	NR	S	Ferric Sulfate	S	S
Bromine, wet gas	NR	S	Ferrous Chloride	S	S
Bromine, liquid	NR	NR	Ferrous Nitrate	S	S
Butyl Acetate	NR	NR	Ferrous Sulfate	S	S
Butyl Alcohol, normal	S	S	Fluoboric Acid	S	S
Butyl Cellosolve	S	NR	Fluosilicic Acid	NR	S
Butylene Glycol	S	S	Formic Acid, vapor	S	S
Butyric Acid	S	S	Fuel Oil	S	S
Calcium Bisulfite	S	S	Furfural	NR	NR
Calcium Carbonate	S	S	Gasoline, Aviation	S	S
Calcium Chlorate	S	S	Gasoline, Ethyl	S	S
Calcium Chloride	S	S	Gluconic Acid	S	S
Calcium Nitrate	S	S	Glucose	S	S
Calcium Sulfate	S	S	Glycerine	S	S
Caprylic Acid	S	S	Hexachlorocyclopentadienl	NR	NA
Carbon Dioxide, gas	S	S	Hydrochloric Acid	S	S
Carbon Disulfide	NR	NR	Hydrofluoric Acid	NR	
Carbonic Acid	S	NA	Hydrogen Bromide, dry gas	S	S
Carbon Monoxide, gas	S	S	Hydrogen Chloride, dry gas	S	S
Carbon Tetrachloride	NR	NR	Hydrogen Chloride, wet gas	S	S
Chloroacetic Acid	NR	S	Hydrogen Fluoride, vapor	NR	S



Fiberglass Cable Tray & Channel

Application Environments

Chemical Environment	Cope-GLAS Performance		Chemical Environment	Cope-GLAS Performance		Chemical Environment	Cope-GLAS Performance	
	Polyester	Vinyl Ester		Polyester	Vinyl Ester		Polyester	Vinyl Ester
Hydrogen Peroxide	NR	S	Potassium Permanganate	NR	S	Trichlorethylene, fumes	NR	NR
Hydrogen Sulfide, dry gas	S	S	Potassium Persulfate	NR	S	Trichloroacetic Acid	NR	S
Hydrogen Sulfide, wet gas	S	S	Potassium Sulfate	S	S	Trimethylamine Hydrochloride	S	S
Hydroiodic Acid	NR	NA	Propylene Glycol	S	S	Triphenyl Phosphite	NR	S
Hypochlorous Acid	NR	S	Silicic Acid	S	NA	Trisodium Phosphate	NR	S
Isodecanol	S	S	Silver Nitrate	S	S	Turpentine, Pure Gum	NR	S
Isopropyl Palmitate	S	S	Sodium Acetate	S	S	Urea	S	S
Jet Fuel (JP-4)	S	S	Sodium Benzoate	S	S	Vinegar	S	S
Kerosene	S	S	Sodium Bicarbonate Saturated	S	S	Water, Cooling Tower	S	S
Lactic Acid	S	S	Sodium Bisulfate	S	S	Water, Demineralized	S	S
Lead Acetate	S	S	Sodium Borate	S	S	Water, Distilled	S	S
Lime Slurry	S	S	Sodium Bromide	S	S	Water, Mine	S	S
Linseed Oil	S	S	Sodium Carbonate	NR	S	Water, Sea	S	S
Lithium Bromide	S	S	Sodium Chlorate	NR	S	Water, Steam Condensate	S	S
Lithium Chloride	S	S	Sodium Chloride	S	S	Water, Tap	S	S
Magnesium Bicarbonate	S	S	Saturated Chlorine	NR	S	Xylene	NR	S
Magnesium Carbonate	S	S	Sodium Chlorite	NR	S	Zinc Chloride	S	S
Magnesium Chloride	S	S	Sodium Cyanide	S	S	Zinc Nitrate	S	S
Magnesium Nitrate	S	S	Sodium Dichromate	NR	S	Zinc Sulfate	S	S
Magnesium Sulfate	S	S	Sodium Di-phosphate	S	S			
Mercuric Chloride	S	S	Sodium Ferricyanide	S	S			
Mercurous Chloride	S	S	Sodium Ferrocyanide	S	S			
Mercury	S	S	Sodium Fluoride	NR	S			
Methyl Alcohol	S	NR	Sodium Hydroxide	NR	S			
Methyl Ethyl Ketone	NR	NR	Sodium Hypochlorite	NR	S			
Milk Waste	S	S	Sodium Hyposulfite	S	NA			
Mineral Oils	S	S	Sodium Mono-phosphate	S	S			
Monochlorobenzene	NR	NR	Sodium Nitrate	S	S			
Naptha	S	S	Sodium Nitrite	S	S			
Napthalene	S	S	Sodium Silicate, pH<12	NR	S			
Nickel Chloride	S	S	Sodium Silicate, pH>12	NR	S			
Nickel Nitrate	S	S	Sodium Sulfate	S	S			
Nickel Sulfate	S	S	Sodium Sulfide	NR	S			
Nickel Sulfonate Plating Solution	S	S	Sodium Sulfite	NR	S			
Nitric Acid	NR	S	Sodium Tetraborate	S	S			
Oleic Acid	S	S	Sodium Thiosulfate	S	S			
Olive Oils	S	S	Sodium Xylene Sulfonate	NR	S			
Oxalic Acid	S	S	Sorbitol Solutions	S	S			
Palmitic Acid	S	S	Sour Crude Oil	S	S			
Perchlorethylene	NR	S	Soya Oil	S	S			
Perchloric Acid	NR	S	Stannous Chloride	S	S			
Phenol	NR	NR	Stearic Acid	S	S			
Phosphoric Acid	S	S	Styrene	NR	NR			
Photographic Solutions	S	NA	Sulfated Detergents	S	S			
Phthalic Anhydride	S	S	Sulfonated Detergents	NR	S			
Pickling Liquids, Acid	S	S	Sulfonyl Chloride, Aromatic	NR	NA			
Pickling Liquids, Alkaline	NR	NA	Sulfur Dioxide, dry gas	S	S			
Picric Acids	NR	NA	Sulfur Dioxide, wet gas	S	S			
Potassium Aluminum Sulfate	S	S	Sulfuric Acid, vapor	S	S			
Potassium Bicarbonate	S	S	Sulfurous Acid	NR	S			
Potassium Bromide	S	S	Tannic Acid	S	S			
Potassium Carbonate	NR	S	Tartaric Acid	S	S			
Potassium Chloride	S	S	Tetrachloroethylene	NR	S			
Potassium Ferricyanide	S	S	Tetrapotassium Pyrophosphate	NR	S			
Potassium Ferrocyanide	S	S	Tetrasodium Pyrophosphate	NR	S			
Potassium Hydroxide	NR	S	Toulene	NR	S			
Potassium Nitrate	S	S	Toluene Di-isocyanate fumes	NR	NA			

FEATURES

SWAGE

I-BEAM

TROF

EAGLE BASKET

CHANNEL

GLAS

AICKINSTRUT

DATA



Structural Designs

Cope-GLAS™ Cable Tray Styles

Cope-GLAS cable tray systems are available in flange-out and flange-in styles. Type CZD deep tray is a flange-out design. Type LC Low Profile tray and standard tray types BE and CE are flange-in designs.

The "Z" siderail profiles allow for easier cable loading and cover attachment or removal.

Cope-GLAS "Deep Z" profile tray, Type CZD, provides six inches of cable fill depth and is only available in NEMA load class C+.

Cope-GLAS "E" Style siderail profiles are flange-in designs that are especially useful when space is a consideration, such as on closely spaced parallel runs or flush wall mountings. "E" rail profile provides four inches of cable fill depth and is available in NEMA load classes C as BE and C+ as CE. Five inch load depth is available in NEMA load class C+ as FE.

The Low Profile cable tray, type LC, is an "E" siderail profile that has a three inch cable loading depth. Type LC cable tray is ideal for control wiring and lighter cable runs that do not require numerous circuits.

All Cope-GLAS cable trays have a 1.5 safety factor that meets the NEMA FG 1 safety factor requirement of 1.5 times the allowable working load.

Cope-GLAS cable tray is also available with a solid bottom upon request. Solid bottom tray consists of a standard ladder tray with a flat fiberglass cover material bonded to the bottom of the tray.

Performance Standards and Class Designations

Tray Type	Class	Working Load (20' Span)	Safety Factor
LC Low Profile	A	50 lbs./ft. (12' span)	1.5
BE Standard	C	100 lbs./ft.	1.5
CE Standard	C+	133 lbs./ft.	2.0
FE Standard	C+	133 lbs./ft.	2.0
CZD Deep	C+	133 lbs./ft.	1.5



Fiberglass Cable Tray & Channel

Selection Guide

Several criteria must be considered in selecting Cope-GLAS cable tray for your application. Factors include load capacity and safety factor; support spans; deflection; cable diameter and tray fill capacity; application environment; space restrictions; fire resistance; future expansion and cost.

Article 392 of the National Electric Code provides cable size and cable fill information. NEMA Standards Publication No. FG 1, Fiberglass Cable Tray Systems, specifies manufacturing standards, performance standards, load class designation specifications and application information such as support span guidelines and temperature deflection information.

The following guidelines will assist you in your selection of Cope-GLAS cable tray:

Step 1: Determine the resin system required based on the application, location, and environment (consult the corrosion resistance guide in the Application Environments section). Cope-GLAS cable tray is available in polyester and vinyl ester resin systems. Vinyl ester provides more corrosion resistance than polyester in some environments.

Step 2: Determine tray loading depth and width. Depending on the size and number of cables needed, use the guidelines in NEC Article 392-8 through -12 to determine tray loading depth and width.

Step 3: Determine rung spacing. The smallest cable or wire bundle determines the rung spacing for ladder type trays. In general, use 18" rung spacing for 2" O.D. or larger, 9" or 12" rung spacing for cables from 1" to 2" O.D., 6" rung spacing for cables from ½" to 1" O.D. and fiberglass channel type trays for smaller cables.

Step 4: Determine the cable load. Calculate in pounds per linear foot the load of the cables to be supported. Consider any extraneous loads such as ice, snow, wind, etc. and add this value to the cable load.

Step 5: Determine the tray style. Cope-GLAS offers two side rail configurations; "E" and "Z".

Refer to the Structural Designs section of this catalog to determine tray style.

Step 6: Determine the support spacing. Normally, cable tray systems are supported at eight foot to twenty foot intervals. Tray may be supported by wall mount brackets, trapeze suspensions, supports from existing structures or it may be floor mounted to minimize deflection.

Splice joints should be placed at or near the quarter point of the span. This guideline should be rigidly followed and non-compliance granted only after careful engineering analysis because of high cable tray stresses which can be generated.

Step 7: Determine the NEMA or CSA load class. The cable tray system should be determined by the combination of cable load (Step 4) and support spacing (Step 6). Consult the Structural Designs section of this catalog or NEMA FG 1 to assist you in the selection of a tray system that meets your requirements.

NEMA Class	Working Load*
A	50 lbs./lin. ft.
B	75 lbs./lin. ft.
C	100 lbs./lin. ft.

* Working load classifications based on 20 foot support spans. Chart not applicable for channel tray.

Installation Procedures

The following information shall be used as a guideline for installing Cope-GLAS cable tray.

Special Considerations

With few exceptions, the installation of fiberglass cable tray does not differ from that of metal tray. All standard installation practices and procedures apply. In general, special handling is not required.

Tools Required

Fiberglass tray is easy to cut and drill. For most installations, standard tools are sufficient; however, for large jobs where many sections require cutting and drilling, high speed steel tools may become dull due to the abrasiveness of glass. In such installations, the use of carbide tipped drills and abrasive (grit) saw blades is recommended.

Cutting Tray in the Field

Tray may be easily cut in the field using a standard hacksaw. If some type of power saw is used, abrasive grit-blades work best. When using a power saw, dust filter masks should be worn. Gloves and long sleeve clothing are also recommended.

Sealing Edges

All cut edges should be sealed. In harsh environments; proper sealing ensures against future migration of corrosive elements into the cut sections.

Drilling Holes for Splice Plates

When drilling holes for splice plates, a $1\frac{3}{32}$ " drill bit will provide a properly sized hole. Clamp a splice plate (using a C-clamp) to the side of the tray and use this plate as a drilling template. The plate should be positioned to allow a $\frac{1}{16}$ " gap between joined side rails or fittings.

Use of Encapsulated Hardware

Tray sections should be joined using Cope-GLAS fiberglass encapsulated stainless steel nuts and bolts (Part #FECNBSS). For maximum protection in extremely harsh environments, apply a generous amount of FIBER-SEAL to the nut and bolt (inside surfaces and threads) just prior to assembly. Assembled splice joints should be tightened to approximately 12 ft/lbs.

Locating Splice Joints

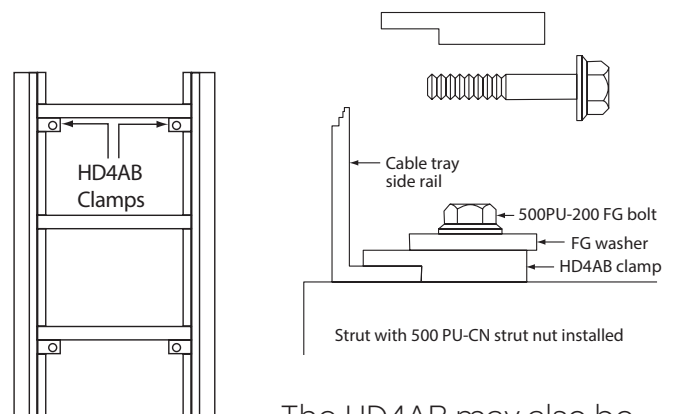
When possible, splice joints should be placed at or near the quarter point of any given support span. This is the point of least mechanical stress. For example: with a section of tray resting on supports spaced 20' apart, the splice plate joints should be located 5' from supports (support span divided by 4).

Expansion Splice Plates

Each Cope-GLAS expansion splice plate allows $\frac{5}{8}$ " total expansion or contraction under varying temperature conditions. A complete table showing expansion plate placement intervals appears in the Cope-GLAS Accessories section of this catalog.

Clamping & Securing Cable Tray

Cope-GLAS provides a special hold down clamp (Part #HD4AB) which grips the bottom flange of the tray and prevents lateral movement. This clamp is commonly used to prevent lateral tray movement when long runs rest on I-Beams or other horizontal support members.

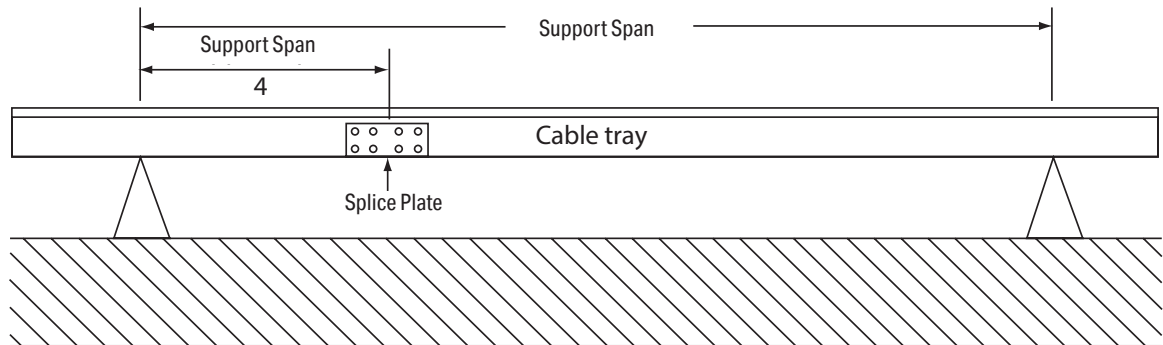


The HD4AB may also be used to secure tray against a vertical wall or bulkhead. In such applications, the clamp should be located adjacent to and below a rung for extra support. When securing tray to a flat vertical bulkhead, it is also acceptable to drill and bolt directly through the bottom flange of the tray. Holes should be centered in the flange and kept as small as possible ($\frac{3}{8}$ " diameter max).

Fiberglass Cable Tray & Channel

Installation Procedures

Splice plate joints should be located as close as possible to the quarter point of the support span.



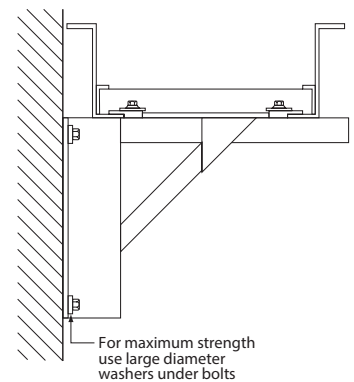
Wall Brackets

Cope-GLAS fiberglass wall brackets may be used to support cable tray adjacent to a vertical wall. Wall brackets are rated at 750 pounds total weight bearing capacity with a safety factor of 3.0.

Bracket spacing may be determined by dividing 750 lbs. by the tray load (in pounds per foot). Example: With a cable tray loading of 100 lbs./ft., divide 750 lbs. by 100 lbs./ft. = 7.5'. One bracket will be required every 7 ½'.

Tray may be secured to the bracket with HD-4 clamps. Note that the brackets are fabricated using Aickinstrut as the main horizontal support member.

Aickinstrut provides a channel nut (Part #500PU-CN) which fits the interior of the strut. This nut, used in conjunction with a fiberglass bolt (Part #500PU-200), washer (Part #WR500) and HD4AB hold down clamp, forms a complete clamping system. Over-torquing should be avoided (3 ft-lbs. max).



Installation Procedures

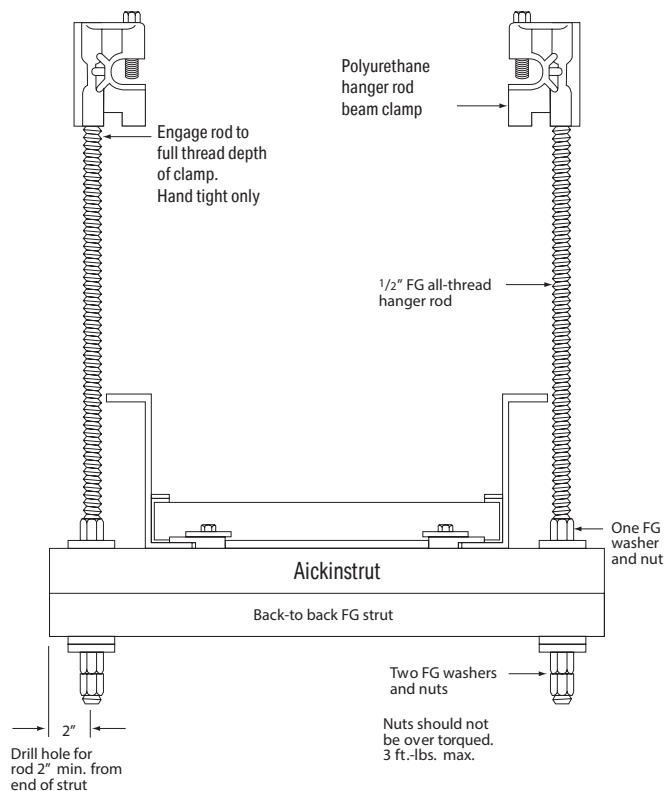
Trapeze Hanging Systems

The fiberglass trapeze hanging system pictured below may be used to support tray in areas where tray cannot be placed on I-Beams or other existing structures. Trapeze hangers are assembled in the field using components from this catalog. Care should be taken to configure the hanger as shown.

When properly assembled, the hanger, pictured below, can support 1000 lbs. with a safety factor of 4 (assuming a balanced load). For NEMA Class C Tray rated at 100 lbs./ft., we recommend a minimum of one hanger for every 10' of tray (1000 lbs. divided by 100 lbs./ft. = 10').

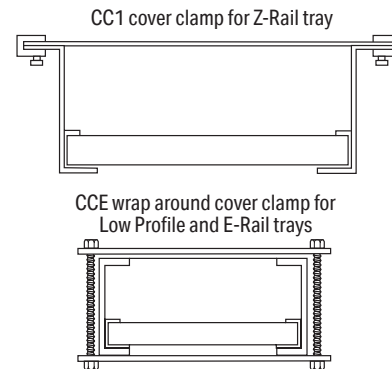
As with the fiberglass wall bracket, HD-4 clamps and associated hardware may be used with these Trapeze Systems.

When trapeze hangers are suspended from I-Beams using polyurethane beam clamps, it is imperative that the fiberglass all-thread rod be screwed completely into the clamp until it bottoms out. Achieving full pull out strength requires total thread engagement. Care should be taken not to over torque the rod.



Cope-GLAS Cover Installation Procedure

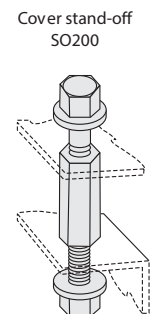
Nylon Drive Rivets (Part #NDR1) are the most economical method to fasten cable tray covers, but they require 1/4" field drilled holes on 24" centers along both siderails.



If cover removal or high winds are a concern, either the CC1 or CCE cover clamp may be desired. The CC1 clamp is designed for use on "Z" Style siderail tray and fittings. This PVC coated steel cover clamp requires no field drilling and is easily removed to allow ready access to the inside tray and cables. Six CC1 clamps are recommended for each ten foot length of cable tray cover.

The CCE clamp is designed for use with flat cover on Low Profile and "E" Style siderail trays and fittings. The CCE clamp is constructed entirely of fiberglass components and is available in either polyester or vinyl ester resin. Two CCE clamps are recommended for each ten foot length of cable tray cover.

Cover stand-offs secure cable tray cover while providing a ventilation gap for cables. The S0200 requires field drilling. Five pairs of clamps are recommended per ten foot length of cable tray cover.



Fiberglass Cable Tray & Channel

Installation Procedures

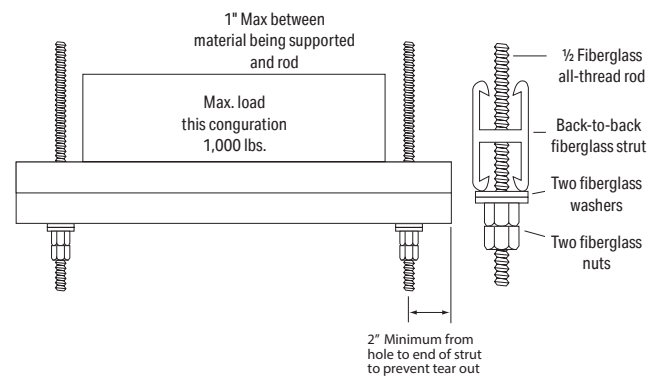
Installation Guidelines:

Fiberglass Trapeze Hanging Systems

The Cope-GLAS cable tray system offers three types of fiberglass trapeze hanging systems: back-to-back strut trapeze, single strut with open end down trapeze, and single strut with open end up trapeze. The specifications associated with each trapeze type are shown below.

Back-to-Back Bonded Strut

1. Fiberglass nuts should not be over-torqued. A snug 3 to 4 ft.-lbs. is sufficient.
2. When supporting a 100 lb./ft. load, the spacing between each trapeze should not exceed ten feet. Under these conditions, each trapeze will be supporting 1000 lbs., thus yielding a support system safety factor of 2.
3. When using beam clamps, only Cope-GLAS RGBC series clamps are acceptable. This clamp provides more thread engagement than clamps designed for steel rod and load ratings are dependent on the extra thread engagement. Care should be taken to ensure that the rod is fully engaged in the clamp nut, but not over torqued (5 ft.-lbs. max.).
4. Material being supported should "fit" the trapeze system as closely as possible. The spacing between the all-thread rod and the material being supported should not exceed 1".



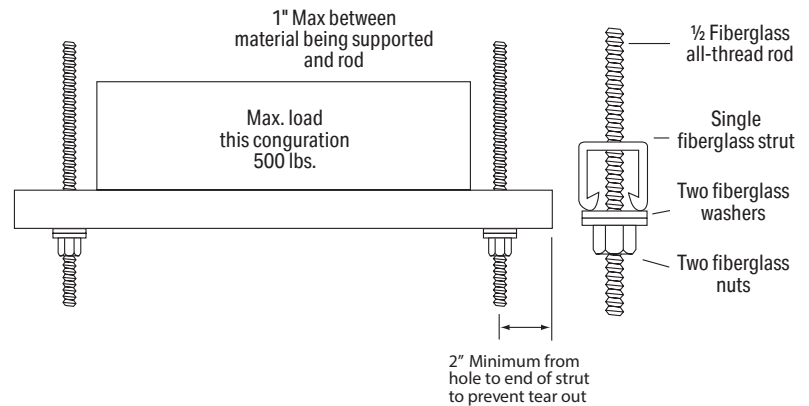
Installation Procedures

Single Strut With Open End Down

1. When supporting a 100 lb./ft. load, the spacing between each trapeze should not exceed five feet. Under these conditions, each trapeze will be supporting 500 lbs., thus yielding a support system safety factor of 2.

2. When using beam clamps, only Cope-GLAS RGBC series clamps are acceptable. This clamp provides more thread engagement than clamps designed for steel rod and load ratings are dependent on the extra thread engagement. Care should be taken to ensure that the rod is fully engaged in the clamp nut, but not over torqued (5 ft-lbs. max.).

3. Material being supported should "fit" the trapeze system as closely as possible. The spacing between the all-thread rod and the material being supported should not exceed 1".

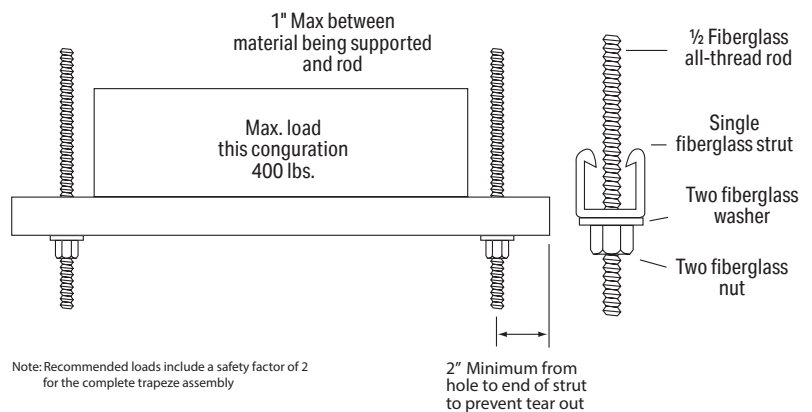


Single Strut With Open End Up

1. To maintain a safety factor of 2, the load for this configuration should not exceed 400 lbs.

2. When using beam clamps, only Cope-GLAS RGBC series clamps are acceptable. This clamp provides more thread engagement than clamps designed for steel rod and load ratings are dependent on the extra thread engagement. Care should be taken to ensure that the rod is fully engaged in the clamp nut, but not over-torqued (5 ft-lbs. max.).

3. Material being supported should "fit" the trapeze system as closely as possible. The spacing between the all-thread rod and the material being supported should not exceed 1".

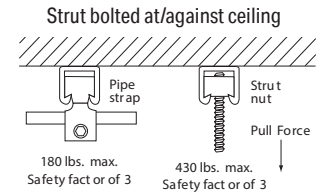


Fiberglass Cable Tray & Channel

Installation Procedures

Aickinstrut® Strut Loading

Aickinstrut is used to hang loads from ceilings where it is common practice to use pipe straps or strut nuts to fasten the loads. The limiting factor in such loading applications is the strength of the non-metallic pipe clamp. Guidelines for these applications are shown at right.

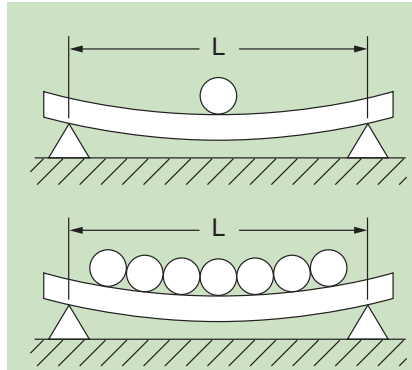
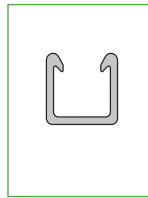


Fiberglass Strut Recommended Loads

(Based on a Safety Factor of 3)

Aickinstrut Light Duty*

1 1/2" x 1 1/8"



Concentrated Load

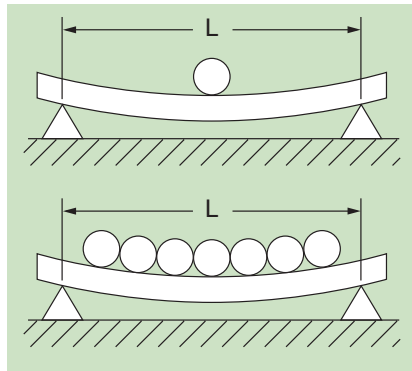
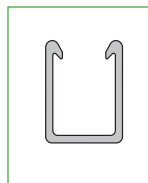
L	Max. Load	Deflection
2'	407 lbs	0.48"
3'	271 lbs	1.08"
4'	203 lbs	1.92"
5'	163 lbs	3.01"

Distributed Load

L	Max. Load	Deflection
2'	815 lbs	0.605"
3'	543 lbs	1.36"
4'	407 lbs	2.41"
5'	326 lbs	3.77"

Aickinstrut Heavy Duty*

1 5/8" x 1 5/8"



Concentrated Load

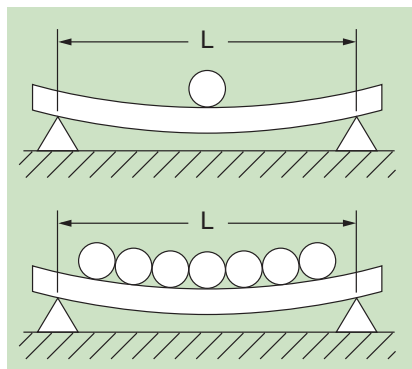
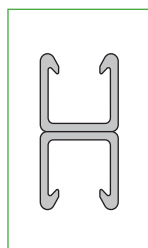
L	Max. Load	Deflection
2'	890 lbs	0.328"
3'	593 lbs	0.737"
4'	445 lbs	1.304"
5'	356 lbs	2.04"

Distributed Load

L	Max. Load	Deflection
2'	1781 lbs.	0.410"
3'	1187 lbs.	0.922"
4'	890 lbs.	1.63"
5'	712 lbs.	2.56"

Aickinstrut Heavy Duty Strut bolted at/against ceiling*

3 1/4" x 1 5/8"



Concentrated Load

L	Max. Load	Deflection
2'	1390 lbs	0.09"
3'	926 lbs	0.203"
4'	695 lbs	0.361"
5'	556 lbs	0.566"

Distributed Load

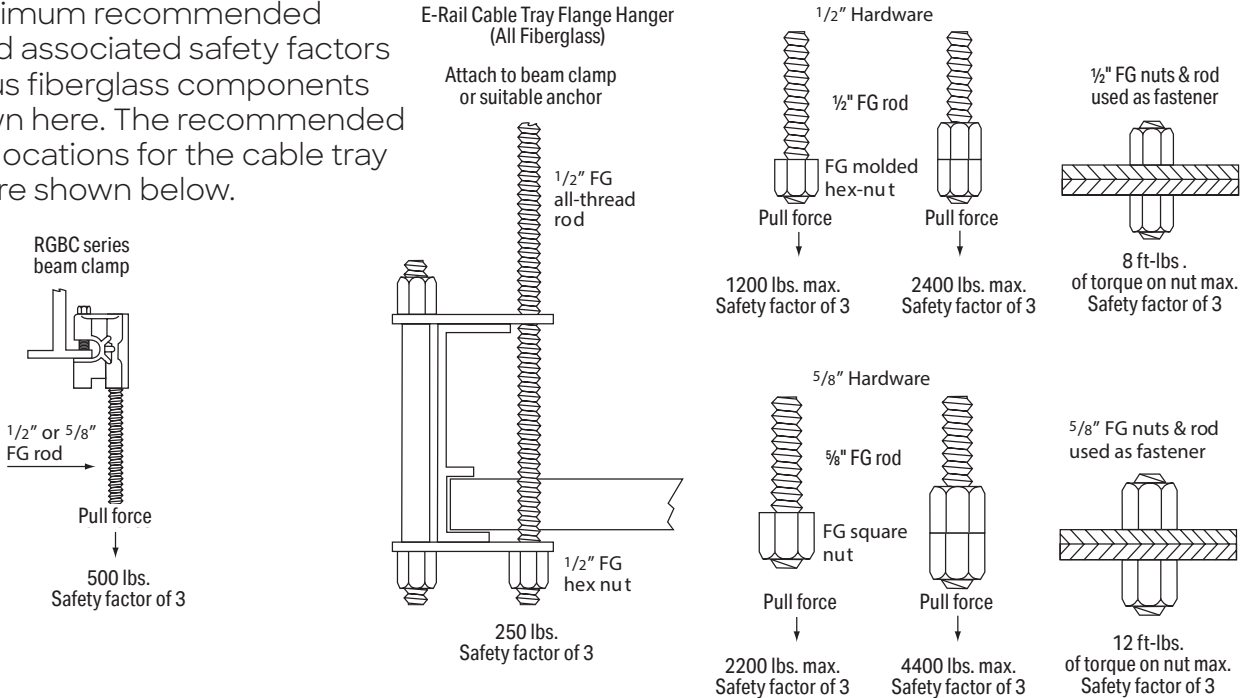
L	Max. Load	Deflection
2'	2780 lbs	0.113"
3'	1853 lbs	0.254"
4'	1390 lbs	0.452"
5'	1112 lbs	0.707"

* See Aickinstrut section for part numbers

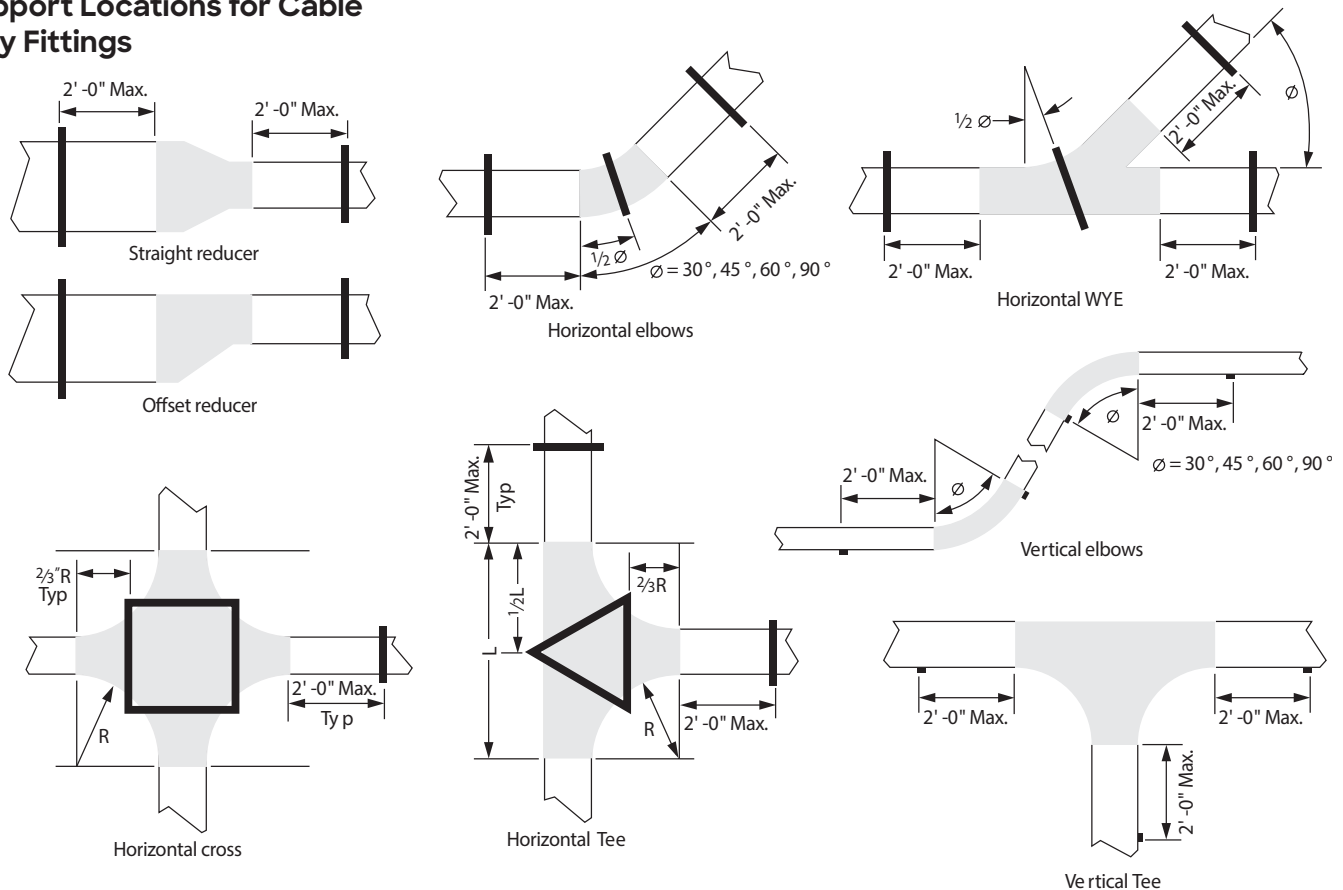
Installation Procedures

Cope-GLAS Fiberglass Components and Associated Hardware Loads

The maximum recommended loads and associated safety factors of various fiberglass components are shown here. The recommended support locations for the cable tray fittings are shown below.



Support Locations for Cable Tray Fittings



Fiberglass Cable Tray & Channel

Straight Sections

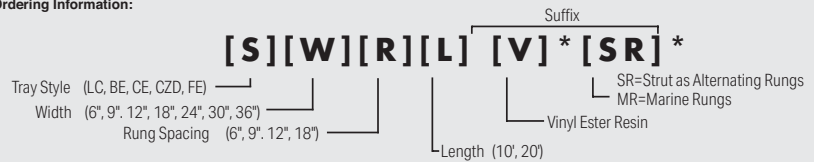
Part Numbering System

All cable tray straight sections are available in polyester or vinyl ester resin. Standard tray lengths are 10' and 20'. Special tray lengths are available upon request. Cable tray sections, except for Low Profile Type LC, can be provided with fiberglass strut substituted as alternating rungs upon request at no additional cost. Type FE tray comes standard with alternating rungs. Solid bottom cable tray sections are available, but require special quotation. All cable tray sections are supplied pre-drilled to accept splice plate fasteners.

Note: Connector plates and hardware are not included and must be ordered separately.

Note: For Solid Bottom (cover on top of rungs) add suffix SB. For Bottom Cover Installed (cover under rungs) add suffix BCI.

Ordering Information:

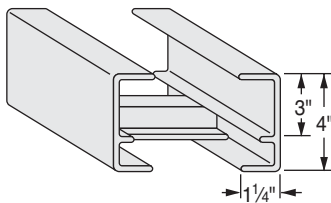


Example: CZD181220VSR
CZD Style Tray, 18\" Width, 12\" Rung Spacing, 20' Long Vinyl Ester Resin, with Alternating Strut Rungs.

* Add suffix \"V\" to specify vinyl ester resin, add \"SR\" to specify strut as alternating rungs, add \"MR\" for marine rungs (see page 206)
Note: See page 189 for cable tray straight section cover options and part numbers.

Type LC Straight Section - C Profile [LC]

- Low Profile Tray
NEMA Class 12A
- (100 lbs./ft. Working Load - 10' Length)
- (50 lbs./ft. Working Load - 12' Length)



10 Foot Length Part Numbers (Type LC)

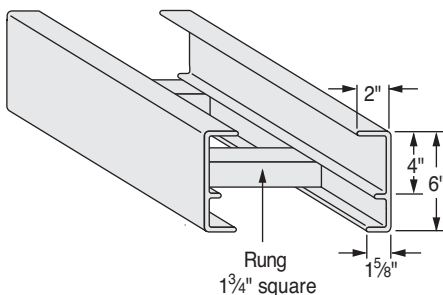
Rung Spacing	Section Width						
	06\" (152mm)	09\" (229mm)	12\" (305mm)	18\" (457mm)	24\" (610mm)	30\" (762mm)	36\" (914mm)
06\"	LC060610	LC090610	LC120610	LC180610	LC240610	LC300610	LC360610
09\"	LC060910	LC090910	LC120910	LC180910	LC240910	LC300910	LC360910
12\"	LC061210	LC091210	LC121210	LC181210	LC241210	LC301210	LC361210

12 Foot Length Part Numbers (Type LC)

Rung Spacing	Section Width						
	06\" (152mm)	09\" (229mm)	12\" (305mm)	18\" (457mm)	24\" (610mm)	30\" (762mm)	36\" (914mm)
06\"	LC060612	LC090612	LC120612	LC180612	LC240612	LC300612	LC360612
09\"	LC060912	LC090912	LC120912	LC180912	LC240912	LC300912	CE360912
12\"	LC061212	LC091212	LC121212	LC181212	LC241212	LC301212	LC361212

Type BE Straight Section - E Profile [BE]

- NEMA Class 20C
- (100 lbs./ft. Working Load - 20' Length)



10 Foot Length Part Numbers (Type BE)

Rung Spacing	Section Width						
	06\" (152mm)	09\" (229mm)	12\" (305mm)	18\" (457mm)	24\" (610mm)	30\" (762mm)	36\" (914mm)
06\"	BE060610	BE090610	BE120610	BE180610	BE240610	BE300610	BE360610
09\"	BE060910	BE090910	BE120910	BE180910	BE240910	BE300910	BE360910
12\"	BE061210	BE091210	BE121210	BE181210	BE241210	BE301210	BE361210

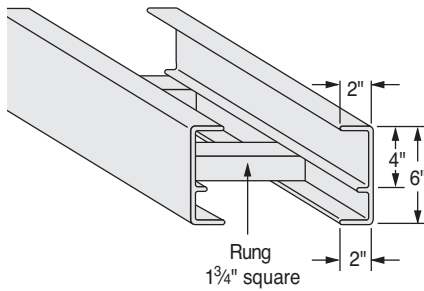
20 Foot Length Part Numbers (Type BE)

Rung Spacing	Section Width						
	06\" (152mm)	09\" (229mm)	12\" (305mm)	18\" (457mm)	24\" (610mm)	30\" (762mm)	36\" (914mm)
06\"	BE060620	BE090620	BE120620	BE180620	BE240620	BE300620	BE360620
09\"	BE060920	BE090920	BE120920	BE180920	BE240920	BE300920	CE360920
12\"	BE061220	BE091220	BE121220	BE181220	BE241220	BE301220	BE361220

Type CE Straight Section - E Profile [CE]

- NEMA Class 20C+
- (133 lbs./ft. Working Load - 20' length)

See ordering information on previous page



10 Foot Length Part Numbers (Type CE)

Rung Spacing	Section Width						
	06" (152mm)	09" (229mm)	12" (305mm)	18" (457mm)	24" (610mm)	30" (762mm)	36" (914mm)
06"	CE060610	CE090610	CE120610	CE180610	CE240610	CE300610	CE360610
09"	CE060910	CE090910	CE120910	CE180910	CE240910	CE300910	CE360910
12"	CE061210	CE091210	CE121210	CE181210	CE241210	CE301210	CE361210
18"	CE061810	CE091810	CE121810	CE181810	CE241810	CE301810	CE361810

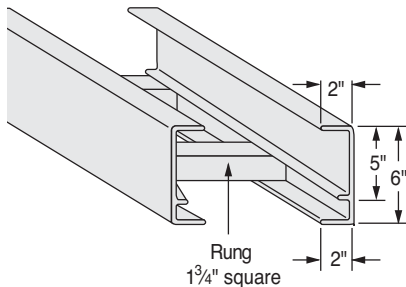
20 Foot Length Part Numbers (Type CE)

Rung Spacing	Section Width						
	06" (152mm)	09" (229mm)	12" (305mm)	18" (457mm)	24" (610mm)	30" (762mm)	36" (914mm)
06"	CE060620	CE090620	CE120620	CE180620	CE240620	CE300620	CE360620
09"	CE060920	CE090920	CE120920	CE180920	CE240920	CE300920	CE360920
12"	CE061220	CE091220	CE121220	CE181220	CE241220	CE301220	CE361220
18"	CE061820	CE091820	CE121820	CE181820	CE241820	CE301820	CE361820

Type FE Straight Section - C Profile [FE]

- NEMA Class 20C+
- (133 lbs./ft. Working Load - 20' length)

See ordering information on previous page



10 Foot Length Part Numbers (Type FE)

Rung Spacing	Section Width						
	06" (152mm)	09" (229mm)	12" (305mm)	18" (457mm)	24" (610mm)	30" (762mm)	36" (914mm)
06"	FE060610	FE090610	FE120610	FE180610	FE240610	FE300610	FE360610
09"	FE060910	FE090910	FE120910	FE180910	FE240910	FE300910	FE360910
12"	FE061210	FE091210	FE121210	FE181210	FE241210	FE301210	FE361210

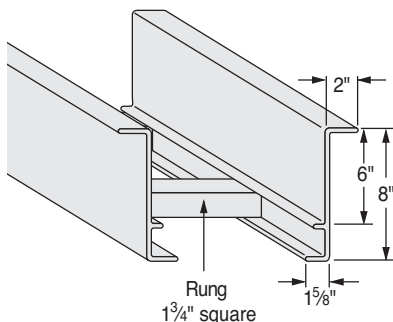
20 Foot Length Part Numbers (Type FE)

Rung Spacing	Section Width						
	06" (152mm)	09" (229mm)	12" (305mm)	18" (457mm)	24" (610mm)	30" (762mm)	36" (914mm)
06"	FE060620	FE090620	FE120620	FE180620	FE240620	FE300620	FE360620
09"	FE060920	FE090920	FE120920	FE180920	FE240920	FE300920	FE360920
12"	FE061220	FE091220	FE121220	FE181220	FE241220	FE301220	FE361220

Type CZD Straight Section - Deep Z Profile [CZD]

- NEMA Class 20C+
- (133 lbs./ft. Working Load - 20' length)

See ordering information on previous page



10 Foot Length Part Numbers (Type CZD)

Rung Spacing	Section Width						
	06" (152mm)	09" (229mm)	12" (305mm)	18" (457mm)	24" (610mm)	30" (762mm)	36" (914mm)
06"	CZD060610	CZD090610	CZD120610	CZD180610	CZD240610	CZD300610	CZD360610
09"	CZD060910	CZD090910	CZD120910	CZD180910	CZD240910	CZD300910	CZD360910
12"	CZD061210	CZD091210	CZD121210	CZD181210	CZD241210	CZD301210	CZD361210
18"	CZD061810	CZD091810	CZD121810	CZD181810	CZD241810	CZD301810	CZD361810

20 Foot Length Part Numbers (Type CZD)

Rung Spacing	Section Width						
	06" (152mm)	09" (229mm)	12" (305mm)	18" (457mm)	24" (610mm)	30" (762mm)	36" (914mm)
06"	CZD060620	CZD090620	CZD120620	CZD180620	CZD240620	CZD300620	CZD360620
09"	CZD060920	CZD090920	CZD120920	CZD180920	CZD240920	CZD300920	CZD360920
12"	CZD061220	CZD091220	CZD121220	CZD181220	CZD241220	CZD301220	CZD361220
18"	CZD061820	CZD091820	CZD121820	CZD181820	CZD241820	CZD301820	CZD361820



Fiberglass Cable Tray & Channel

Covers

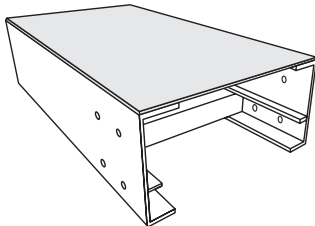
Cope-GLAS Cable Tray Covers

Covers are used where cable protection is necessary or desired. Two Cope-GLAS cover designs, flat and peaked, are offered. The flat cover suits most applications and is more widely used; however, where the accumulation of snow or other particulate is likely, the peak cover will help shed excessive loads on the cable tray system. Flat covers are available in polyester or vinyl ester resin and are offered in

10' lengths. To specify vinyl ester resin, add the suffix "V" to the part number. Peaked covers are made from polypropylene and are supplied in black. Peaked covers are not available for Cope-GLAS fittings.

Installation procedures for covers are located in the Installation Procedures section of this catalog.

Flat Cover



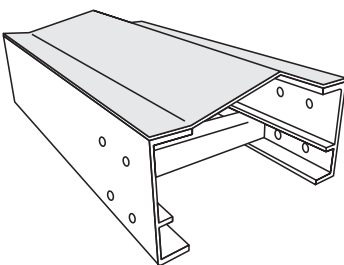
Flat Cover for Z Shaped Profile Siderail

Tray Width	Polyester Resin	Vinyl Ester Resin	Wt./ Ft.
06"	CTC06	CTC06V	0.8
09"	CTC09	CTC09V	1
12"	CTC12	CTC12V	1.2
18"	CTC18	CTC18V	1.6
24"	CTC24	CTC24V	2.1
30"	CTC30	CTC30V	2.6
36"	CTC36	CTG36V	3

Flat Cover for E Shaped Profile Siderail

Tray Width	Polyester Resin	Vinyl Ester Resin	Wt./ Ft.
06"	CTCE06	CTCE06V	0.7
09"	CTCE09	CTCE09V	0.9
12"	CTCE12	CTCE12V	1.1
18"	CTCE18	CTCE18V	1.5
24"	CTCE24	CTCE24V	2
30"	CTCE30	CTCE30V	2.5
36"	CTCE36	CTCE36V	2.9

Peaked Cover



Peaked Cover for Z Shaped Profile Siderail

Tray Width	PVC	Wt./Ft.
06"	PTK06	0.9
09"	PTK09	1.1
12"	PTK12	1.3
18"	PTK18	1.8
24"	PTK24	2.3
30"	PTK30	2.9
36"	PTK36	3.3

Peaked Cover for E Shaped Profile Siderail

Tray Width	PVC	Wt./Ft.
06"	PTKE06	1
09"	PTKE09	1.2
12"	PTKE12	1.7
18"	PTKE18	1.8
24"	PTKE24	2.2
30"	PTKE30	2.8
36"	PTKE36	3.3

Note: 5' Lengths only

Note: Bottom covers available in two options.

- 1) Installed under tray (BCI)
- 2) Sits on top of rungs (SB)

Fittings

All types and widths of tray are available as fittings with the Cope-GLAS Cable Tray System. All fittings are pre-drilled at the factory to accept splice plate fasteners. Rung spacing specified in the tray straight sections does not necessarily apply to fittings.

Molded Fittings

Type LC Low Profile and Type BE, CE & FE tray fitting side rails are resin transfer molded with smooth radius corners. Smooth radius fittings are compact and the curved rail shape is an aid for cable pulling. The following fittings are available in smooth radius:

Type LC Smooth Radius Fittings

- 90° Inside Vertical Assemblies
- 90° Outside Vertical Assemblies
- 90° Horizontal Bend Assembly
- All 12" width, 12" radius
- Vertical Tee Assemblies
- Horizontal Tee Assemblies
- Horizontal Cross Assemblies

Type BE, CE & FE Smooth Radius Fittings

- 90° Inside Vertical Assemblies
12" & 24" radius
- 90° Outside Vertical Assemblies
12" & 24" radius
- 90° Horizontal Bend Assemblies
24" & 36" width, 12" radius; 6", 9", 12", 18",
& 24" width, 24" radius
- Vertical Tee Assemblies
12" & 24" radius
- Horizontal Tee Assemblies
12" & 24" radius
- Horizontal Cross Assemblies
12" & 24" radius

Mitered Fittings

All 12" and 36" radius assemblies and reducing assemblies for FE and CZD trays are fabricated from cut and mitered side rail sections. All BE and CE tray, 36" radius fittings and horizontal bends (with the exception of those listed in the molded fittings text) will also be mitered.

Custom Fittings

Factory engineering support will help with your special requirements; 30° and 60° bends along with other special fittings are available upon request.

Cable Tray Fitting Part Numbering System

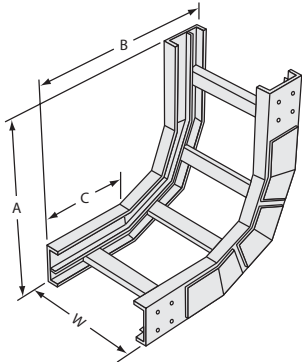
With each fitting drawing, there is an example of how to create the correct part number for the fittings and its cover. Alternating strut and rungs can be provided by using the suffix SR.



Fiberglass Cable Tray & Channel

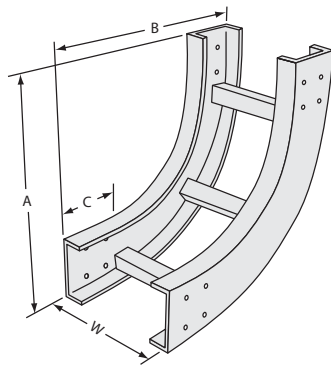
Fittings

90° Vertical Inside Elbows [V90I]



90° Vertical Inside Elbows - Mitered

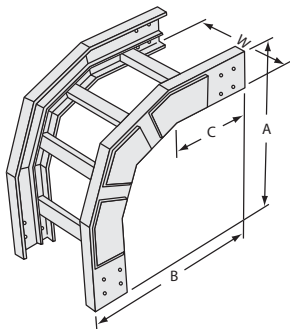
Tray Style	Radius	A or B	C (Straight)	Close-Coupled Inside & Outside Fittings	
				Rise	Length
CZD	12" (305mm)	32" (813mm)	13 ⁵ / ₁₆ " (346mm)	52 ¹ / ₁₆ " (1322mm)	52" (1321mm)
CZD	24" (610mm)	44" (1118mm)	13 ⁵ / ₁₆ " (346mm)	76 ¹ / ₁₆ " (1932mm)	76" (1930mm)
FE, CZD, BE, CE	36" (914mm)	54" (1372mm)*	13 ⁵ / ₁₆ " (346mm)	100 ¹ / ₁₆ " (2542mm)	100" (2540mm)



90° Vertical Inside Elbows - Smooth Radius

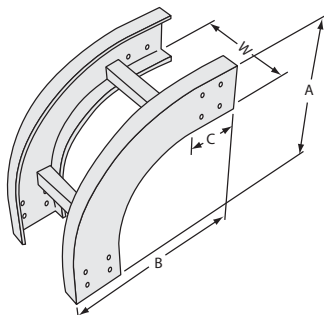
Tray Style	Radius	A or B	C (Straight)	Close-Coupled Inside & Outside Fittings	
				Rise	Length
LC	12" (305mm)	20" (508mm)	5" (127mm)	36 ¹ / ₁₆ " (916mm)	36" (914mm)
LC	24" (610mm)	32" (813mm)	5" (127mm)	60 ¹ / ₁₆ " (1526mm)	60" (1524mm)
BE, CE, FE	12" (305mm)	21 ¹⁵ / ₁₆ " (557mm)	6" (152mm)	37 ¹⁵ / ₁₆ " (964mm)	37 ⁷ / ₈ " (914mm)
BE, CE, FE	24" (610mm)	33 ¹⁵ / ₁₆ " (862mm)	6" (152mm)	61 ¹⁵ / ₁₆ " (1574mm)	61 ⁷ / ₈ " (1524mm)

90° Vertical Outside Elbows [V90O]



90° Vertical Outside Elbows - Mitered

Tray Style	Radius	A or B	C (Straight)	Close-Coupled Inside & Outside Fittings	
				Rise	Length
CZD	12" (305mm)	28" (711mm)	12 ¹³ / ₁₆ " (325mm)	52 ¹ / ₁₆ " (1322mm)	52" (1321mm)
CZD	24" (914mm)	40" (1016mm)	12 ¹³ / ₁₆ " (325mm)	76 ¹ / ₁₆ " (1932mm)	76" (1930mm)
BE, CE, FE	36" (914mm)	52" (1321mm)	13 ³ / ₁₆ " (335mm)	100 ¹ / ₁₆ " (2542mm)	100" (2540mm)
CZD	36" (914mm)	52" (1321mm)	12 ¹³ / ₁₆ " (325mm)	100 ¹ / ₁₆ " (2542mm)	100" (2540mm)

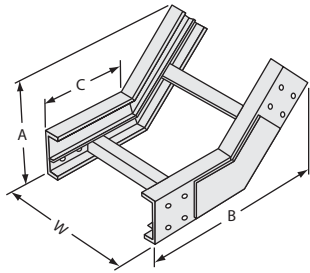


90° Vertical Outside Elbows - Smooth Radius

Tray Style	Radius	A or B	C (Straight)	Close-Coupled Inside & Outside Fittings	
				Rise	Length
LC	12" (305mm)	20" (508mm)	5" (127mm)	36 ¹ / ₁₆ " (916mm)	36" (914mm)
LC	24" (610mm)	32" (813mm)	5" (127mm)	60 ¹ / ₁₆ " (1526mm)	60" (1524mm)
BE, CE, FE	12" (305mm)	21 ¹⁵ / ₁₆ " (557mm)	6" (152mm)	37 ¹⁵ / ₁₆ " (964mm)	37 ⁷ / ₈ " (914mm)
BE, CE, FE	24" (610mm)	33 ¹⁵ / ₁₆ " (862mm)	6" (152mm)	61 ¹⁵ / ₁₆ " (1574mm)	61 ⁷ / ₈ " (1524mm)

Fittings

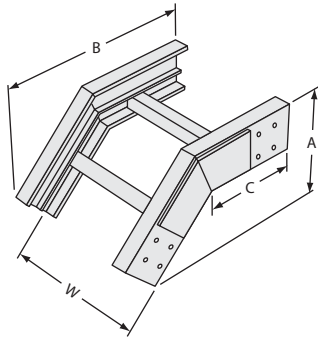
45° Vertical Inside Elbows [V45I]



45° Vertical Inside Elbows [V45I]

Tray Style	A	B	C (Straight)	Close-Coupled Inside & Outside Fittings	
				Rise	Length
LC	11¼" (286mm)	20½" (517mm)	11½" (304mm)	15¾" (399mm)	37⅞" (963mm)
BE, CE, FE	14½" (368mm)	24¾" (629mm)	12" (305mm)	18¾" (476mm)	45¼" (1149mm)
CZD	15½" (405mm)	24¾" (629mm)	11¾" (284mm)	18¾" (476mm)	45¼" (1149mm)

45° Vertical Outside Elbows [V45O]



45° Vertical Outside Elbows [V45O]

Tray Style	A	B	C (Straight)	Close-Coupled Inside & Outside Fittings	
				Rise	Length
LC	11¼" (286mm)	20½" (517mm)	11½" (304mm)	15¾" (399mm)	37⅞" (963mm)
BE, CE, FE	14½" (368mm)*	24¾" (629mm)	12" (305mm)	18¾" (476mm)	45¼" (1149mm)
CZD	16½" (419mm)	26⅛" (664mm)	12" (305mm)	18¾" (476mm)	45¼" (1149mm)

Note: Do not include radius in part number for 45° & 30° bends

Vertical inside/Outside Bends - Part Numbering System

The following information will help you order vertical bends for your application. Special fittings are available upon request. Strut rungs can be provided every other rung at no additional cost. Solid bottom fittings are available through special quotation. Smooth radius vertical bends are available for Type LC, BE, CE, & FE cable trays in 12" and 24" radius. All Type CZD fittings will be mitered as will BE, CE, & FE 36" radius fittings.

Ordering Information Fittings:

[S][B][T][W][R] [V] * [SR] *

Tray Style (LC, BE, CE,)
 Bend (V90°, V45°, V30°)
 Type of Bend (I=Inside, O=Outside)

Suffix
 [SR]=Strut as Alternating Rungs
 MR=Marine Rungs
 Vinyl Ester Resin

Radius (12", 24", 36")**
 Width (6", 9", 12", 18", 24", 30", 36")

Example: CEV90I2412VSR
 CE Style Tray, 90° Inside Vertical Bend, 24" Wide, 12" Radius,
 Vinyl Ester Resin, With Alternating Strut Rungs.

*Add suffix "V" to specify vinyl ester resin, add "SR" to specify strut as alternating rungs,
 add "MR" to specify Marine Rungs (see page 206)
 **Radius needed for 90 degree (V90) fittings only

Ordering Information Covers:

[C][B][T][W][R] [V] *

Cover: (C = C/E Profiles)
 (Z = Z Profile)
 Bend (V90°, V45°, V30°)
 Type of Bend (I=Inside, O=Outside)

Suffix
 Vinyl Ester Resin

Radius (12", 24", 36")**
 Width (6", 9", 12", 18", 24", 30", 36")

Example: ZV90I2412V
 Cover Style Z, 90° Inside Vertical Bend, 24" Wide, 12" Radius, Vinyl Ester Resin.

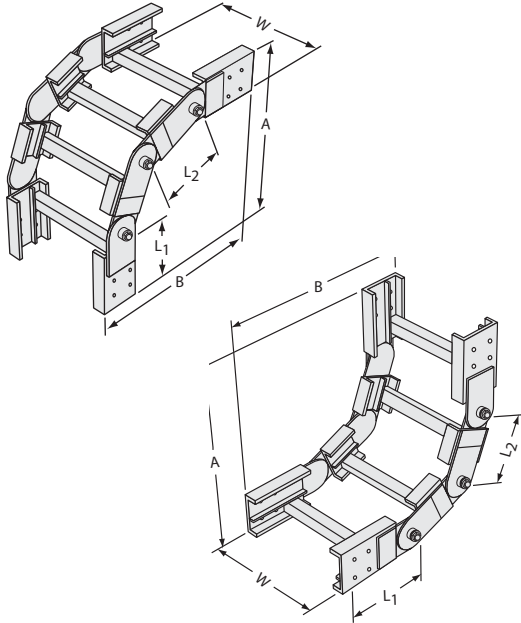
* Add suffix "V" to specify vinyl ester resin
 ** only used for 90



Fiberglass Cable Tray & Channel

Fittings

0° thru 90° Vertical Adjustable Elbows [VAB]



Tray Style	Radius	A or B (@90°)	Leg L1	Leg L2
LC	12" (305mm)	26 $\frac{1}{8}$ " (664mm)	11 $\frac{1}{4}$ " (286mm)	9 $\frac{7}{8}$ " (251mm)
LC	24" (610mm)	38 $\frac{1}{16}$ " (967mm)	11 $\frac{1}{4}$ " (286mm)	19" (483mm)
BE, CE, FE, CZD	12" (305mm)	28" (711mm)	12 $\frac{1}{8}$ " (308mm)	9 $\frac{7}{8}$ " (251mm)
BE, CE, FE, CZD	24" (610mm)	39 $\frac{15}{16}$ " (1014mm)	12 $\frac{1}{8}$ " (308mm)	19" (483mm)
BE, CE, FE, CZD	36" (914mm)	51 $\frac{15}{16}$ " (1319mm)	12 $\frac{1}{8}$ " (308mm)	28 $\frac{3}{16}$ " (716mm)

Vertical Adjustable Bends - Part Number System

This versatile fitting is fully adjustable from 0° to 90° and can accommodate either an inside or outside bend. Strut rungs can be provided every other rung at no additional cost.

Ordering Information Fittings:

[S][VAB][W][R] [V] * [SR] *

Tray Style (LC, BE, CE, FE, CZD) ——— Vertical Adjustable Bend

Radius (12", 24", 36")

Width (6", 9", 12", 18", 24", 30", 36")

SR=Strut as Alternating Rungs
 MR=Marine Rungs

Vinyl Ester Resin

Example: CEVAB2412VSR
 CE Style Tray, Vertical Adjustable Bend, 24" Wide, 12" Radius, Vinyl Ester Resin, with Alternating Strut Rungs.

* Add suffix "V" to specify vinyl ester resin, add "SR" to specify strut as alternating rungs, add "MR" to specify Marine rungs (see page 206)

Ordering Information Covers:

[C][VAB][W][R] [V] *

Cover: (C = C/E Profiles)
 (Z = Z Profile)

Radius (12", 24", 36")

Width (6", 9", 12", 18", 24", 30", 36")

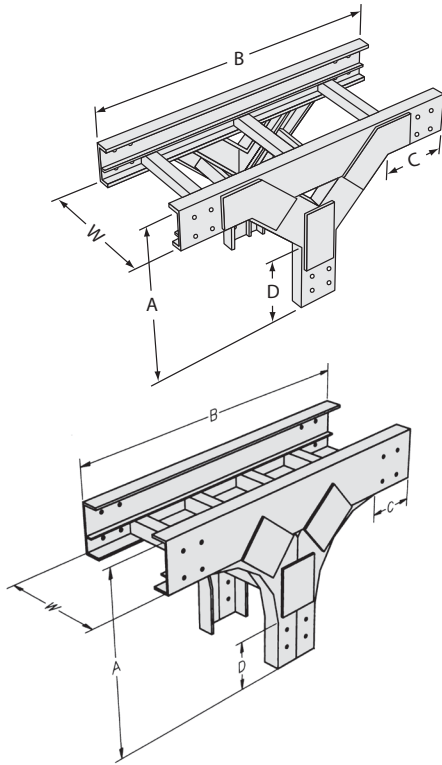
Vinyl Ester Resin

Example: ZVAB2412V
 Z Style Cover, Vertical Adjustable Bend, 24" Wide, 12" Radius, Vinyl Ester Resin.

* Add suffix "V" to specify vinyl ester resin

Fittings

Vertical Tees [VT]



Vertical Tees-Mitered

Tray Style	Radius	A	B	C (Straight)	D (Straight)
CZD	12" (305mm)	29 ³ / ₄ " (756mm)	46" (1169mm)	8 ¹ / ₄ " (210mm)	11" (279mm)
CZD	24" (610mm)	37" (940mm)	66" (1676mm)	14 ¹ / ₂ " (368mm)	14 ¹ / ₂ " (368mm)
BE, CE, FE	36" (914mm)	47" (1194mm)	88" (2235mm)	18 ¹ / ₁₆ " (478mm)	18 ¹ / ₁₆ " (478mm)
CZD	36" (914mm)	49" (1245mm)	90" (2286mm)	18 ¹ / ₁₆ " (478mm)	18 ¹ / ₁₆ " (478mm)

Vertical Tees-Smooth Radius

Tray Style	Radius	A	B	C (Straightmm)
LC	12" (305mm)	20" (508mm)	36" (914mm)	5" (127mm)
LC	24" (610mm)	32" (813mm)	60" (1524mm)	5" (127mm)
BE, CE, FE	12" (305mm)	21 ¹ / ₁₆ " (557mm)	37 ⁷ / ₈ " (962mm)	6" (152mm)
BE, CE, FE	24" (610mm)	33 ¹ / ₁₆ " (862mm)	61 ⁷ / ₈ " (1572mm)	6" (152mm)

Vertical Tee - Part Number System

This assembly can be provided with strut rungs at no additional cost. Solid bottom fittings are available through special quotation. Smooth radius vertical tees are available for Type BE, CE, and FE cable trays in 12" and 24" radius. All type CZD fittings will be mitered as will Type BE, CE, and FE 36" radius fittings.

Ordering Information Fittings:

[S][VT][W][R] [V] * [SR] *

Tray Style (LC, BE, CE, FE, CZD) — Vertical Tee — Width (6", 9", 12", 18", 24", 30", 36") — Radius (12", 24", 36") — Suffix (SR=Strut as Alternating Rungs, MR=Marine Rungs, Vinyl Ester Resin)

Example: LCVT1224SR
 LC Style Tray, Vertical Tee, 12" Wide, 24" Radius, Polyester Resin, with Alternating Strut Rungs.

* Add suffix "V" to specify vinyl ester resin, add "SR" to specify strut as alternating rungs, add "MR" to specify Marine rungs (see page 206)

Ordering Information Covers:

[C][VT][W][R] [V] *

Cover: (C = C/E Profiles, Z = Z Profile) — Vertical Tee — Width (6", 9", 12", 18", 24", 30", 36") — Radius (12", 24", 36") — Suffix (Vinyl Ester Resin)

Example: ZVT1224
 Z Style Cover, Vertical Tee, 12" Wide, 24" Radius, Polyester Resin.

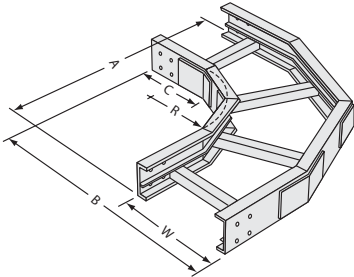
* Add suffix "V" to specify vinyl ester resin



Fiberglass Cable Tray & Channel

Fittings

90° Horizontal Elbows [H90]



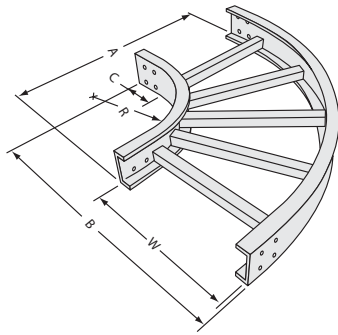
90° Horizontal Elbows-Mitered

Tray Style	Radius	A or B (W Tray Width)	C (Straight)	Close-Coupled 90° Fittings	
				Offset	Length
LC	12" (305mm)	23 ¹ / ₈ " (594mm)+W	11 ¹ / ₄ " (286mm)	46 ¹ / ₁₆ " (1187mm)+W	46 ¹ / ₂ " (1181 mm)+W
LC	24" (610mm)	35 ³ / ₈ " (899mm)+W	11 ¹ / ₄ " (286mm)	70 ⁵ / ₁₆ " (1794mm)+W	70 ⁹ / ₁₆ " (1772mm)+W
BE, CE, FE, CZD	12" (305mm)	25" (635mm)+W*	12 ¹ / ₁₆ " (329mm)**	50 ¹ / ₁₆ " (1272mm)+W	50" (1270mm)+W
BE, CE, FE, CZD	24" (610mm)	37" (940mm)+W*	12 ¹ / ₁₆ " (329mm)**	74 ¹ / ₁₆ " (1881mm)+W	74" (1880mm)+W
BE, CE, FE, CZD	36" (914mm)	49" (1245mm)+W*	12 ¹ / ₁₆ " (329mm)**	98 ¹ / ₁₆ " (2491mm)+W	98" (2489mm)+W

*For Z style siderail add 2" (51mm) to accommodate the upper flange

**For Z style siderail use 12³/₁₆" (321mm)

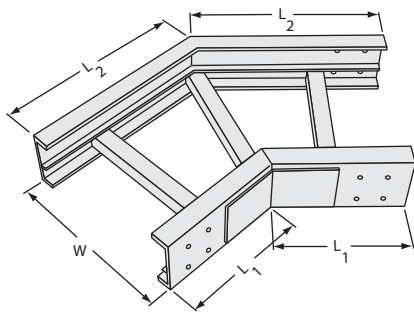
90° Horizontal Elbows-Smooth Radius



Tray Style	Width	Radius	A or B (W Tray Width)	C (Straight)	Close-Coupled 90° Fittings	
					Offset	Length
LC	12" (305mm)	12" (305mm)	17 ¹ / ₈ " (435mm)+W	5 ¹ / ₁₆ " (127mm)	34 ¹ / ₁₆ " (865mm)+W	34" (864mm)+W
BE, CE, FE	24" (610mm)	12" (305mm)	18 ¹ / ₄ " (464mm)+W	6" (152mm)	60 ¹ / ₁₆ " (1526mm)+W	60" (1524mm)+W
BE, CE, FE	36" (914mm)	12" (305mm)	18 ¹ / ₄ " (464mm)+W	6" (152mm)	60 ¹ / ₁₆ " (1526mm)+W	60" (1524mm)+W
BE, CE, FE	6" (152mm)	24" (610mm)	30 ³ / ₄ " (768mm)+W	6" (152mm)	72 ¹ / ₁₆ " (1870mm)+W	72" (1829mm)+W
BE, CE, FE	9" (229mm)	24" (610mm)	30 ³ / ₄ " (768mm)+W	6" (152mm)	72 ¹ / ₁₆ " (1870mm)+W	72" (1829mm)+W
BE, CE, FE	12" (305mm)	24" (610mm)	30 ³ / ₄ " (768mm)+W	6" (152mm)	72 ¹ / ₁₆ " (1870mm)+W	72" (1829mm)+W
BE, CE, FE	18" (457mm)	24" (610mm)	30 ³ / ₄ " (768mm)+W	6" (152mm)	72 ¹ / ₁₆ " (1870mm)+W	72" (1829mm)+W
BE, CE, FE	24" (610mm)	24" (610mm)	30 ³ / ₄ " (768mm)+W	6" (152mm)	72 ¹ / ₁₆ " (1870mm)+W	72" (1829mm)+W

45° Horizontal Elbows [H45]

45° Horizontal Elbows [H45]



Tray Style	Tray Widths	L1	L2	Close-Coupled 45° Fittings	
				Offset	Length
LC	6" (152mm)	10 ⁵ / ₈ " (270mm)	12 ¹ / ₁₆ " (323mm)	16 ³ / ₁₆ " (411mm)	39" (991mm)
LC	9" (229mm)	10 ⁵ / ₈ " (270mm)	13 ¹ / ₁₆ " (354mm)	17 ¹ / ₁₆ " (434mm)	41 ¹ / ₈ " (1045mm)
LC	12" (305mm)	10 ⁵ / ₈ " (270mm)	15 ³ / ₁₆ " (386mm)	17 ¹ / ₁₆ " (456mm)	43 ¹ / ₄ " (1099mm)
LC	18" (457mm)	10 ⁵ / ₈ " (270mm)	17 ¹ / ₁₆ " (449mm)	19 ¹ / ₁₆ " (500mm)	47 ¹ / ₂ " (1207mm)
LC	24" (610mm)	10 ⁵ / ₈ " (270mm)	20 ³ / ₁₆ " (512mm)	21 ⁷ / ₁₆ " (545mm)	51 ³ / ₄ " (1314mm)
LC	30" (762mm)	10 ⁵ / ₈ " (270mm)	22 ⁵ / ₁₆ " (575mm)	23 ³ / ₄ " (591mm)	56" (1422mm)
LC	36" (914mm)	10 ⁵ / ₈ " (270mm)	25 ¹ / ₈ " (638mm)	25" (635mm)	60 ¹ / ₄ " (1530mm)
BE, CE, FE, CZD	6" (152mm)	13" (330mm)	15 ¹ / ₂ " (394mm)	20 ³ / ₁₆ " (513mm)	48 ¹ / ₁₆ " (1237mm)
BE, CE, FE, CZD	9" (229mm)	13" (330mm)	16 ³ / ₄ " (425mm)	21 ¹ / ₁₆ " (535mm)	50 ¹ / ₁₆ " (1291mm)
BE, CE, FE, CZD	12" (305mm)	13" (330mm)	18" (457mm)	21 ¹ / ₁₆ " (557mm)	52 ¹ / ₁₆ " (1345mm)
BE, CE, FE, CZD	18" (457mm)	13" (330mm)	20 ⁷ / ₁₆ " (519mm)	23 ¹ / ₁₆ " (602mm)	57 ³ / ₁₆ " (1453mm)
BE, CE, FE, CZD	24" (610mm)	13" (330mm)	22 ¹ / ₁₆ " (583mm)	25 ⁷ / ₁₆ " (646mm)	61 ³ / ₈ " (1559mm)
BE, CE, FE, CZD	30" (762mm)	13" (330mm)	25 ⁷ / ₁₆ " (646mm)	27 ³ / ₁₆ " (691mm)	65 ⁵ / ₈ " (1667mm)
BE, CE, FE, CZD	36" (914mm)	13" (330mm)	27 ¹ / ₁₆ " (710mm)	29" (737mm)	69 ⁷ / ₈ " (1775mm)

Fittings

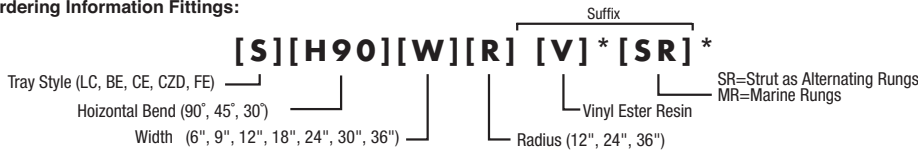
The following information will help you order horizontal elbows for your application. Special fittings are available upon requires. Strut rungs can be provided every other rung at no additional cost. Solid bottom fittings are available through special quotation. Smooth radius elbows are available in the following tray sizes:

LC 90° Horizontal Elbow: 12" width, 12" radius

BE, CE, & FE 90° Horizontal Elbow: 24" and 36" width, 12" radius

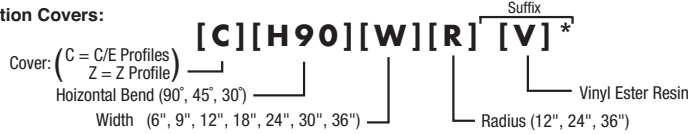
BE, CE, & FE 90° Horizontal Elbow: 6", 9", 12", 18", 24", and 30" width, 24" radius

Ordering Information Fittings:



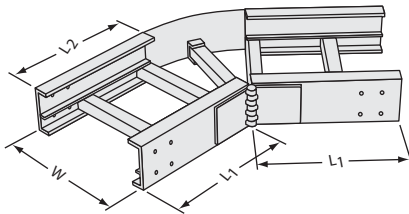
* Add suffix "V" to specify vinyl ester resin, add "SR" to specify strut as alternating rungs, add "MR" to specify Marine rungs (see page 206)
** Radius needed for 90 degree (H90) fittings only
Example: CEH903624V: CE Style Tray, 90 degree Horizontal Bend, 36" Wide, 24" Radius, Vinyl Ester Resin

Ordering Information Covers:



Example: CH453624V: C Style Cover, 45° Horizontal Bend, 36" Wide, 24" Radius, Vinyl Ester Resin
* Add suffix "V" to specify Vinyl ester resin
** Radius needed for 90 degree (H90) fittings only

Horizontal Adjustable Elbows [HAB]



Horizontal Adjustable Elbows [HAB]

Tray style	Angle Adjustment Range	Leg L1	Leg L2
LC	25°-65°	16 1/16" (408mm)	16 1/16" (408mm)
LC	60°-100°	16 1/16" (408mm)	16 1/16" (408mm)
BE, CE, FE, CZD	25°-65°	18" (457mm)	18" (457mm)
BE, CE, FE, CZD	60°-100°	18" (457mm)	18" (457mm)

Horizontal Adjustable Elbows Part Number System

This versatile fitting is offered in two designs to accommodate a full range of adjustment.

- Style A design is adjustable from 25° to 65°
- Style B design is adjustable from 60° to 100°

The range of adjustment must be specified when ordering this fitting. Strut rungs can be provided every other rung at no additional cost. Horizontal adjustable bends are available in all tray widths except 6".

Ordering Information Fittings:



* Add suffix "V" to specify vinyl ester resin, add "SR" to specify strut as alternating rungs, add "MR" to specify Marine rungs (see page 206)
** Radius needed for 90 degree (H90) fittings only
Example: BEHAB12B: C Style Cover, Horizontal Adjustable Bend, 12" Wide, 60° to 100° Adjustment Range, Polyester Resin

Ordering Information Covers:



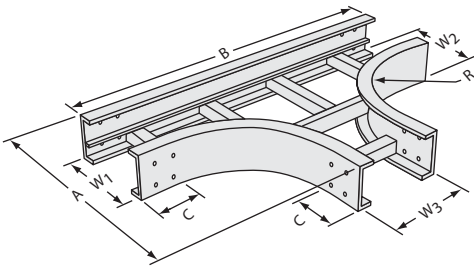
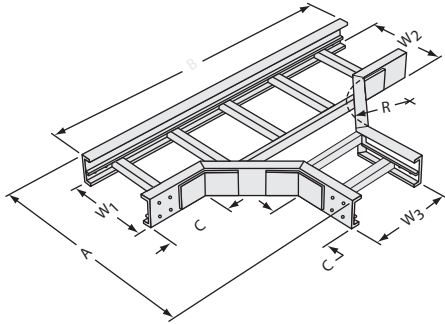
* Add suffix "V" to specify Vinyl ester resin
Example: CHAB12B: BE Style Tray, Horizontal Adjustable Bend, 12" Wide, 60° to 100° Adjustment Range, Polyester Resin



Fiberglass Cable Tray & Channel

Fittings

Horizontal Tees [T]



Horizontal Tees-Mitered

Tray Style	Radius	A (W=Tray Width)	B	C (Straight)
CZD	12" (305mm)	27" (686mm)+W1 or W2	50" (1270mm)+W3	12 ³ / ₁₆ " (310mm)
CZD	24" (610mm)	39" (991mm)+W1 or W2	74" (1880mm)+W3	12 ³ / ₁₆ " (310mm)
BE, CE, FE, CZD	36" (914mm)	49" (1245mm)+W1* or W2*	98" (2489mm)+W3	12 ⁵ / ₁₆ " (329mm)*

t For Reducing Tees use wider of W1 or W2

*For Z style siderail add 2" (51mm) to accommodate the upper flange

*For Z style siderail use 12⁵/₁₆" (310mm)

Horizontal Tees-Smooth Radius

Tray Style	Radius	A (W=Tray Width)	B	C (Straight)
LC	12" (305mm)	17 ¹ / ₈ " (435mm)+W1 or W2	34" (864mm)+W3	5" (127mm)
LC	24" (610mm)	41 ¹ / ₈ " (1095mm)+W1 or W2	58" (1473mm)+W3	5" (127mm)
BE, CE, FE	12" (305mm)	18 ¹ / ₄ " (464mm)+W1 or W2	36" (914mm)+W3	6" (152mm)
BE, CE, FE	24" (610mm)	30" (786mm)+W1 or W2	60" (1524mm)+W3	6" (152mm)

For Reducing Tees use wider of W1 or W2

Horizontal Tees - Part Number System

This assembly is commonly provided with equal width legs for standard tees but can also be provided with reduced width legs. Strut rungs can be provided every other rung at no additional cost. Solid bottom fittings and reducing tees are available through special quotation. Smooth radius horizontal tees are available for Type LC, BE, CE, and FE cable trays in 12" and 24" radius. All Type CZD fittings will be mitered as will Type BE, CE, and FE 36" radius fittings.

Ordering Information Fittings:

[S][T][W][R] [V] * [SR] *

Tray Style (LC, BE, CE, CZD, FE) — [S]
Horizontal Tee — [T]
Width (6", 9", 12", 18", 24", 30", 36") — [W]
Radius (12", 24", 36") — [R]
Vinyl Ester Resin — [V]
SR=Strut as Alternating Rungs
MR=Marine Rungs

Example: CET3624
CE Style Tray, Horizontal Tee, 36" Wide, 24" Radius, Polyester Resin.

* Add suffix "V" to specify vinyl ester resin, add "SR" to specify strut as alternating rungs, add "MR" to specify Marine rungs (see page 206)

Ordering Information Covers:

[C][T][W][R] [V] *

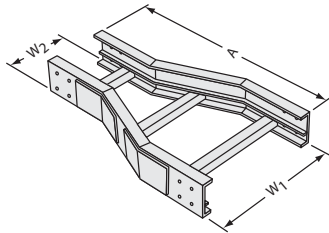
Cover: (C = C/E Profiles)
(Z = Z Profile) — [C]
Horizontal Tee — [T]
Width (6", 9", 12", 18", 24", 30", 36") — [W]
Radius (12", 24", 36") — [R]
Vinyl Ester Resin — [V]

Example: ZT3624
Z Style Cover, Horizontal Tee, 36" Wide, 24" Radius, Polyester Resin

* Add suffix "V" to specify Vinyl ester resin

Fittings

Straight Reducers [RS]



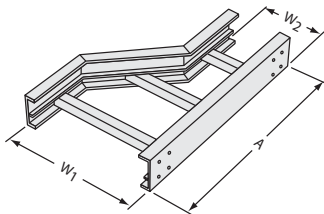
Straight Reducers [RS]

Part Number	W1*	W2*	LC Tray Style A	FE, BE, CE, CZD Tray Style A
RS0906	09" (229mm)	06" (152mm)	21" (533mm)	33 ³ / ₁₆ " (852mm)
RS1206	12" (305mm)	06" (152mm)	30" (762mm)	41 ¹ / ₁₆ " (1043mm)
RS1209	12" (305mm)	09" (229mm)	21" (533mm)	33 ³ / ₁₆ " (852mm)
RS1806				40 ¹ / ₂ " (1029mm)
RS1809	18" (457mm)	06" (152mm)	30" (762mm)	36 ⁷ / ₈ " (937mm)
RS1812				41 ¹ / ₁₆ " (1043mm)
RS2406				47 ³ / ₄ " (1213mm)
RS2409	24" (610mm)	06" (152mm)	30" (762mm)	44 ¹ / ₈ " (1121 mm)
RS2412				40 ¹ / ₂ " (1029mm)
RS2418	24" (610mm)	18" (457mm)		41 ¹ / ₁₆ " (1043mm)
RS3006	30" (762mm)	06" (152mm)	30" (762mm)	55" (1397mm)
RS3009	30" (762mm)	09" (229)		51 ³ / ₈ " (1305mm)
RS3012				47 ³ / ₄ " (1213mm)
RS3018	30" (762mm)	12" (305mm)	30" (762mm)	40 ¹ / ₂ " (1029mm)
RS3024				41 ¹ / ₁₆ " (1043mm)
RS3606				62 ³ / ₁₆ " (1580mm)
RS3609	36" (914mm)	06" (152mm)	30" (762mm)	58 ⁹ / ₁₆ " (1487mm)
RS3612				55" (1397mm)
RS3618				47 ³ / ₄ " (1213mm)
RS3624	36" (914mm)	18" (457mm)	30" (762mm)	40 ¹ / ₂ " (1029mm)
RS3630				41 ¹ / ₁₆ " (1043mm)

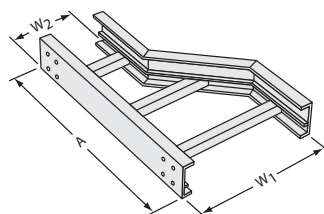
*For Z style siderail add 4" (102mm) to accommodate the upper flange.

Right & Left Reducers [RR] or [RL]

Right Reducer



Left Reducer



Right & Left Reducers [RR] or [RL]

Part Number	W1*	W2*	LC Tray Style A	FE, BE, CE, CZD Tray Style A
RR0906 or RL0906	09" (229mm)	06" (152mm)		33 ¹ / ₄ " (845mm)
RR1206 or RL1206	12" (305mm)	06" (152mm)	30" (762mm)	40 ¹ / ₂ " (1029mm)
RR1209 or RL1209	12" (305mm)	09" (229mm)		33 ¹ / ₄ " (845mm)
RR1806 or RL1806				38" (965mm)
RR1809 or RL1809	18" (457mm)	06" (152mm)	30" (762mm)	35" (889mm)
RR1812 or RL1812				40 ¹ / ₂ " (1029mm)
RR2406 or RL2406			39" (991mm)	44" (1118mm)
RR2409 or RL2409	24" (610mm)	06" (152mm)	39" (991mm)	41" (1041mm)
RR2412 or RL2412			30" (762mm)	38" (965mm)
RR2418 or RL2418	24" (610mm)	18" (457mm)	30" (762mm)	40 ¹ / ₂ " (1029mm)
RR3006 or RL3006	30" (762mm)	06" (152mm)	45" (1143mm)	50" (1270mm)
RR3009 or RL3009	30" (762mm)	09" (229mm)	39" (991 mm)	47" (1194mm)
RR3012 or RL3012			39" (991 mm)	44" (1118mm)
RR3018 or RL3018	30" (762mm)	12" (305mm)	30" (762mm)	38" (965mm)
RR3024 or RL3024			30" (762mm)	40 ¹ / ₂ " (1029mm)
RR3606 or RL3606			48" (1219mm)	56" (1422mm)
RR3609 or RL3609	36" (914mm)	06" (152mm)	45" (1143mm)	53" (1346mm)
RR3612 or RL3612			45" (1143mm)	50" (1270mm)
RR3618 or RL3618			39" (991mm)	44" (1118mm)
RR3624 or RL3624	36" (914mm)	18" (457mm)	30" (762mm)	38" (965mm)
RR3630 or RL3630			30" (762mm)	40 ¹ / ₂ " (1029mm)

*For Z style siderail add 4" (102mm) to accommodate the upper flange



Fiberglass Cable Tray & Channel

Fittings

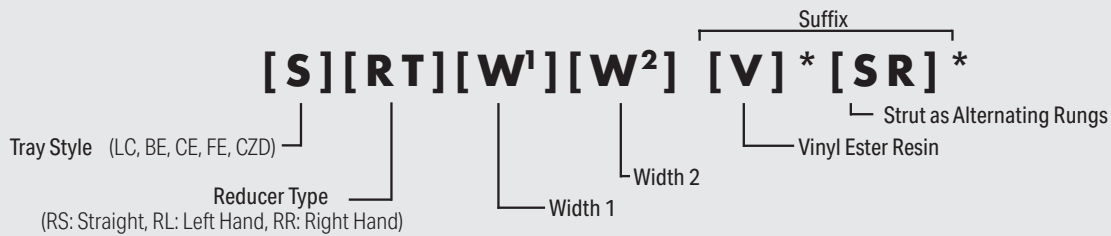
Reducers - Part Number System

Reducers are available in three styles:

- Straight
- Left Hand Offset
- Right Hand Offset

Strut rungs can be provided at every other rung location at no additional cost. Solid bottom fittings are available through special quotation.

Ordering Information Fittings:



Example: BERS2412
BE Style Tray, Straight Reducer, 24" Width,
12" Width, Polyester Resin.

* Add suffix "V" to specify vinyl ester resin, add "SR" to specify strut as alternating rungs

Splice Plates

The Cope-GLAS Cable Tray System offers a full line of fiberglass accessories to suit any application. All accessories must be ordered individually to complete the system.

Splice Plates

Splice plates for system assembly come in six variations designed for specific applications: straight, expansion straight, fixed angle horizontal, fixed angle vertical, horizontal adjustable and vertical adjustable. Low Profile (LC) splice plates require six 3/8" fasteners while splice plates for standard and deep tray require

eight 3/8" fasteners. Splice plates and fasteners are sold separately and are not provided with straight sections or fittings. The part numbers shown are for polyester splice plates. To specify vinyl ester splice plates, add the suffix "V" to the part number. All Low Profile splice plate part numbers are designated with an "L" prefix.

Example: LS12

Splice plates are shown on the next page.

Ordering Information Covers:

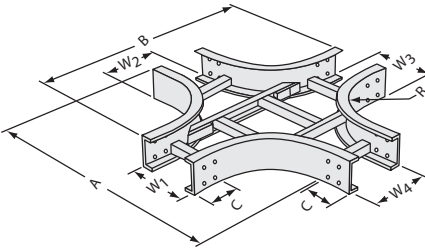
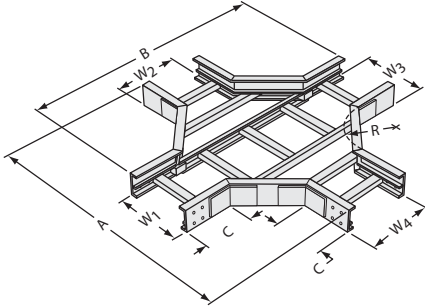


Example: CRS2412
C Style Cover, Straight Reducer, 24" Width, 12" Width, Polyester Resin

* Add suffix "V" to specify Vinyl ester resin

Fittings

Horizontal Cross [X]



Horizontal Cross-Mitered

Tray Style	Radius	A (W=Tray Width)	B	C (Straight)
CZD	12" (305mm)	50" (1270mm)+W1 or W3	50" (1270mm)+W2 or W4	12 ³ / ₁₆ " (310mm)
CZD	24" (610mm)	74" (1880mm)+W1 or W3	74" (1880mm)+W2 or W4	12 ³ / ₁₆ " (310mm)
BE, CE, FE, CZD	36" (914mm)	98" (2489mm)+W1 or W3	98" (2489mm)+W2 or W4	12 ¹ / ₈ " (329mm)*

For Reducing Cross use wider of W1 or W3
 For Reducing Cross use wider of W2 or W4
 *For Z style siderail use 12³/₁₆" (310mm)

Horizontal Cross-Smooth Radius

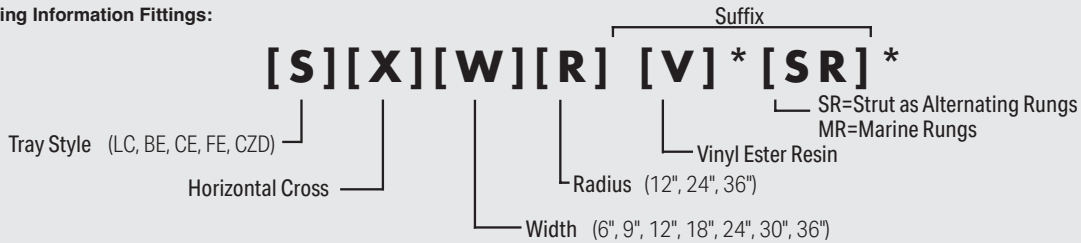
Tray Style	Radius	A (W=Tray Width)	B	C (Straight)
LC	12" (305mm)	34" (864mm)+W1 or W3	34" (864mm)+W1 or W3	5" (127mm)
LC	24" (610mm)	58" (1473mm)+W1 or W3	58" (1473mm)+W1 or W3	5" (127mm)
BE, CE, FE	12" (305mm)	36" (914mm)+W1 or W3	36" (914mm)+W1 or W3	6" (152mm)
BE, CE, FE	24" (610mm)	60" (1524mm)+W1 or W3	60" (1524mm)+W1 or W3	6" (152mm)

For Reducing Cross use wider of W1 or W3
 For Reducing Cross use wider of W2 or W4

Horizontal Cross - Part Number System

This assembly is commonly provided with equal width legs for standard crosses but can also be provided with reduced width legs. Strut rungs can be provided every other rung at no additional cost. Solid bottom fittings and reducing crosses are available through special quotation. Smooth radius horizontal crosses are available for Type LC, BE, CE, and FE cable trays in 12" and 24" radius. All Type CZD fittings will be mitered as will Type BE, CE, and FE 36" radius fittings.

Ordering Information Fittings:



Example: BEX1812
 BE Style Tray, Horizontal Cross, 18" Wide, 12" Radius, Polyester Resin.

* Add suffix "V" to specify vinyl ester resin, add "SR" to specify strut as alternating rungs, add "MR" to specify Marine rungs (see page 206)

Ordering Information Covers:



Example: CX1812
 C Style Cover, Horizontal Cross, 18" Wide, 12" Radius, Polyester Resin

* Add suffix "V" to specify Vinyl ester resin



Fiberglass Cable Tray & Channel

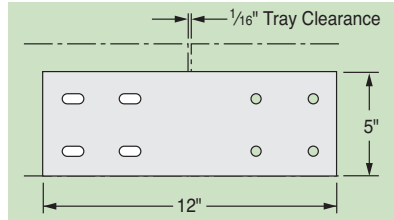
Splice Plates

Straight Splice Plates

Used for tray to tray or tray to fitting connections.

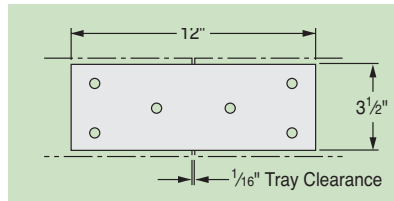
Standard Part No. (S12)

Note: Not sold in pairs
Requires 8 nuts/bolts per plate



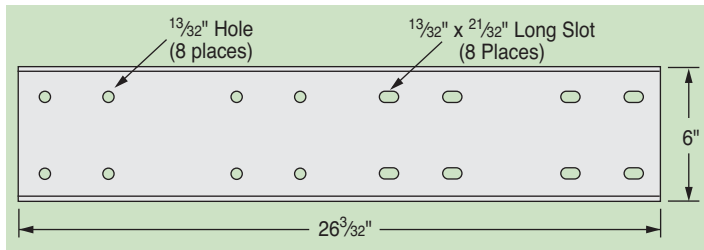
Low Profile Part No. (LS12)

Note: Not sold in pairs
Requires 6 nuts/bolts per plate



Mid-Span Part No. (S12-MID)

Note: Cannot be used w/ Z shape



Note: The S12-MID is for use with BE and CE Style Fiberglass Cable Tray

Fixed Angle Horizontal Splice Plates

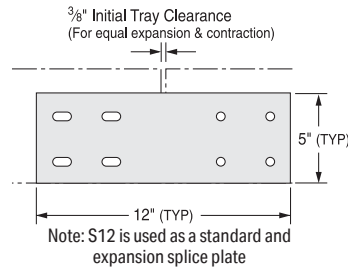
Often field situations necessitate unplanned changes in the horizontal or vertical direction of a cable tray run. Fixed angle and adjustable splice plates provide a means to make horizontal and vertical direction changes in the field. These splice plates may also be used to fabricate special fittings.

Used for 90°, 45°, and 22.5° horizontal direction changes.

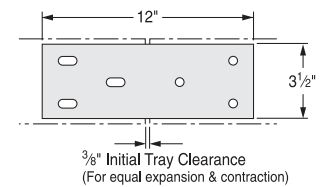
Expansion Splice Plates

Used to accommodate thermal expansion/contraction of extended straight tray runs. The following table should be used as a guideline in determining the number of expansion splice plates needed for your application.

Standard (Part Numbers: ES12)



Low Profile (Part Numbers: LES12)



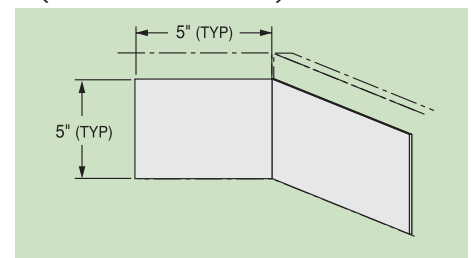
Expansion Splice Plates

Temperature Differential Deg. F	Tray Length for 1 Expansion	Max Distance Between Expansion Splices
25°	667 ft.	417 ft.
50°	333 ft.	208 ft.
75°	222 ft.	139 ft.
100°	167 ft.	104 ft.
125°	133 ft.	83 ft.
150°	111 ft.	69 ft.
175°	95 ft.	59 ft.

The 1 inch slotted holes in each expansion connector allow 5/8" total expansion or contraction.

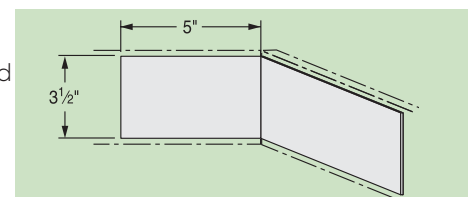
Standard Part No. (H90, H45, H22.5)

Note: Holes must be drilled in field. Hardware purchased separately



Low Profile Part No. (LH90, LH45, LH22.5)

Note: Holes must be drilled in field. Hardware purchased separately



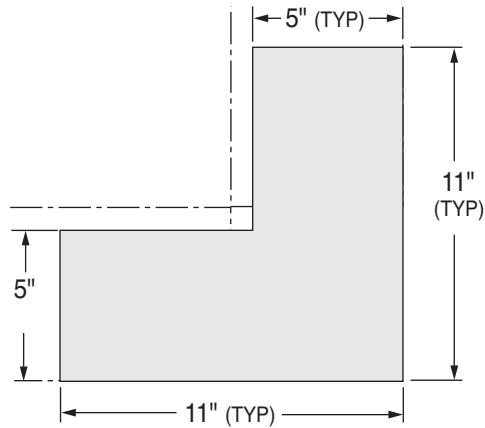
Splice Plates & Hardware

Fixed Angle Vertical Splice Plates

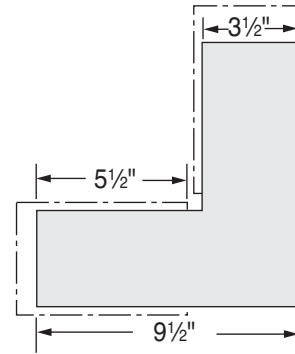
Used for 90°, 45°, and 22.5° vertical direction changes.

Note: Holes must be drilled in field. Hardware purchased separately.

Standard Part No. (V90, V45, V22.5)



Low Profile Part No. (LV90, LV45, LV22.5)



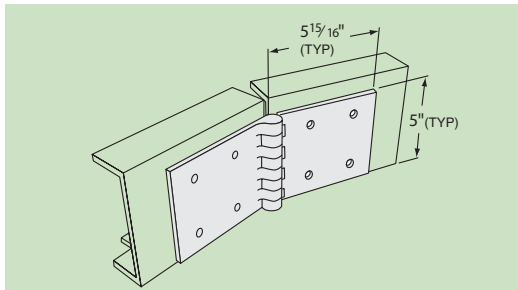
Adjustable Horizontal Splice Plates

Used for variable horizontal direction changes.

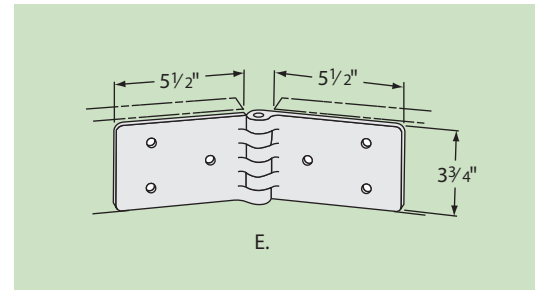
Note: H12 requires (8) Nuts/bolts

Note: LH12 requires (6) Nuts/bolts

Standard Part No. (H12)



Low Profile Part No. (LH12)



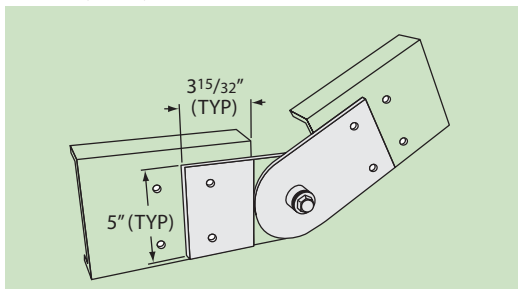
Adjustable Vertical Splice Plates

Used for variable vertical direction changes.

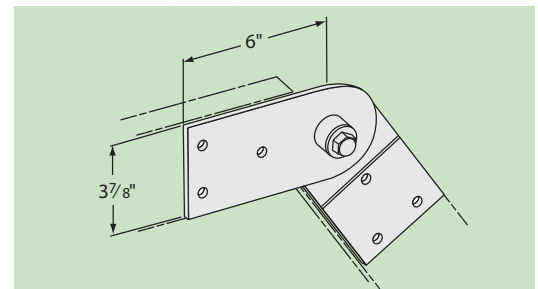
Note: V12 requires (4) Nuts/bolts

Note: LV12 requires (6) Nuts/bolts

Standard Part No. (V12)



Low Profile Part No. (LV12)

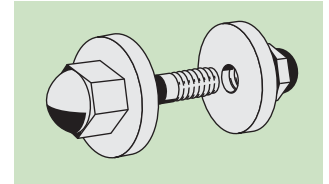


Fiberglass Cable Tray & Channel

Tray Covers & Accessories & Hardware

Cable Tray Hardware

The Cope-GLAS cable tray system offers four types of splice plate fasteners: Fiberglass Encapsulated 316 Stainless Steel, Standard 316 Stainless Steel, Silicon Bronze and Monel. Each bolt set with the exception of the fiberglass encapsulated hardware includes one bolt, one nut, and two washers. The fiberglass encapsulated hardware includes molded collars which act as washers and provide a smooth sealing surface. It is recommended that all splice plate fasteners be installed with a hex head socket wrench and torqued to a maximum 15 ft-lbs.

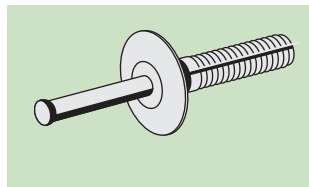


Cable Tray Hardware

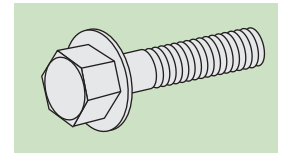
Part Numbers	Size	Type
FECNBSS	3/8"-16" x 1"	Fiberglass Encapsulated
SSNBW2-316	3/8"-16" x 1"	316 Stainless Steel
SBNBW2	3/8"-16" x 1"	Silicon Bronze
MONBW2	3/8"-16" x 1"	Monel

Rivet Part No. (NDR1)
Nylon Drive Rivet is used to secure cover or barrier strip to tray.

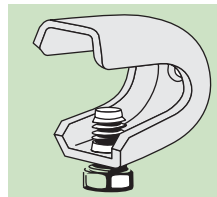
Note: (8) per 10' length



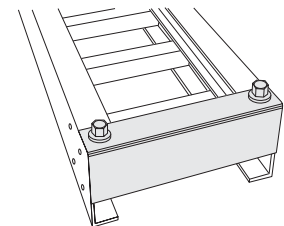
Fiberglass Bolt Part No. (500PU-200)
1/2"-13 x 2" polyurethane hex head bolt for use with hold down clamps.



Cover Clamp Part No. (CC1)
PVC coated steel cover clamp designed for use with "Z" profile tray and fittings.

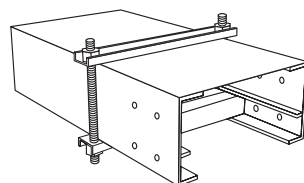


End Plates
To order appropriate End Plate, see chart. To specify vinyl ester, add suffix "V" to part number (hardware not included).



Cover Clamp Part No. (CCE)
Fiberglass cover clamp designed for use with all "E" profile trays and fittings. Available in polyester or vinyl ester. To specify vinyl ester, add suffix "V" to part number.

Part No.	Tray Width	Part No.	Tray Width
CCE06	06"	CCE24	24"
CCE09	09"	CCE30	30"
CCE12	12"	CCE36	36"
CCE18	18"		



Tray Width	LC	CZD	BE/CE/FE
06"	EPL06	EPZ06	EPE06
09"	EPL09	EPZ09	EPE09
12"	EPL12	EPZ12	EPE12
18"	EPL18	EPZ18	EPE18
24"	EPL24	EPZ24	EPE24
30"	EPL30	EPZ30	EPE30
36"	EPL36	EPZ36	EPE36

Tray Covers & Accessories

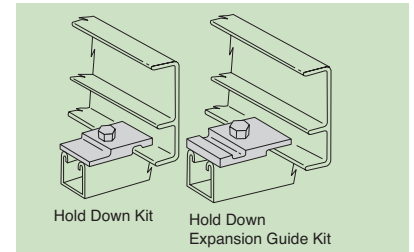
Hold Down Package Part No. (HDBLTNT)

The Hold Down Package consists of the necessary components for securing Cope-GLAS tray to strut or wall brackets. The Hold Down Package includes one each of the following items: HD4AB (hold down clamp), 500PU-200 (1/16"-13 x 2" fiberglass bolt) and 500PU-CN (1/2" strut nut). The components are also available individually. Installation procedures are located in the Installation Procedures Section of this catalog.

Combination Hold-Down Clamp and Expansion Guide

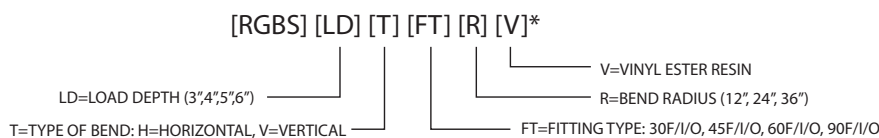
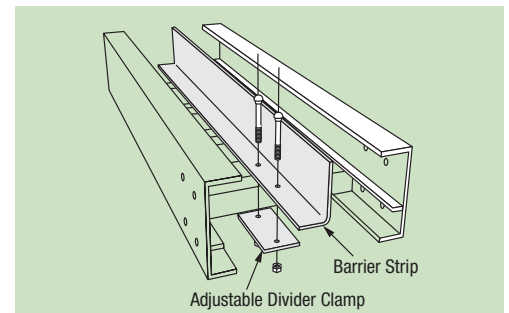
Part No. (HD4AB)

Hold-Down side secures and prevents lateral movement of cable tray while expansion side allows for thermal expansion and contraction of cable tray.



Barrier Strip Part No. (RGSB4V)

Barrier strip is supplied in ten foot lengths and is intended for field installation unless otherwise indicated. For securing barrier strip to tray, we recommend the use of Nylon Drive Rivets (Part #NDR1) which require field drilling or Adjustable Divider Clamps (Part #ADC1). Barrier strip is available in polyester and vinyl ester resin types. To specify vinyl ester, add suffix "V" to part number.

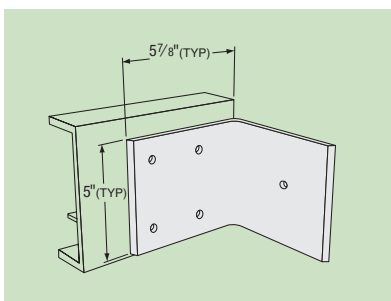


Tray Style	Part Number	Dimensions
Low Profile	LC	3" x 2" x 3/16"
Standard	BE, CE, FE	4" x 2" x 3/16"
Deep	CZD	6" x 2" x 3/16"

*Use RGSB4 with FE tray

Floor & Panel Flange Part No. (LF400, F400)

Available in polyester and vinyl ester resin. To specify vinyl ester, add suffix "V" to part number.



Adjustable Divider Clamp

The Adjustable Divider Clamp makes locating the barrier strip a snap. The ADC is available in polyester and vinyl ester resin. To specify vinyl ester, add suffix "V" to part number. Two clamps per ten foot section of barrier strip are recommended.

Tray Style	Part Number
Low Profile	LADC1
Standard	ADC1
Deep	ADC1

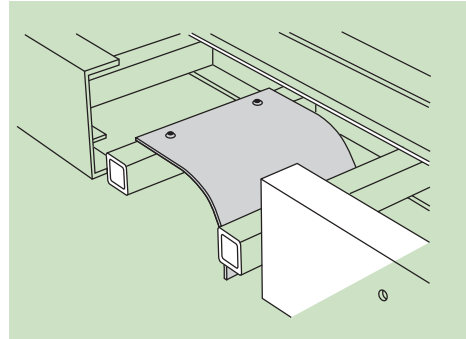


Fiberglass Cable Tray & Channel

Accessories

Drop Outs

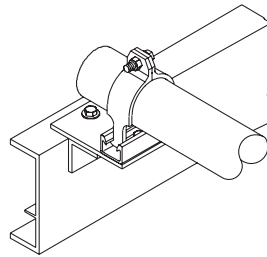
Drop Outs are easily fastened to tray rungs with two Nylon Drive Rivets (NDR1). Nylon Drive Rivets are separate order items. To specify vinyl ester, add suffix "V" to part number.



Tray Width	Part Number
06"	D006
09"	D009
12"	D012
18"	D018
24"	D024
30"	D030
36"	D036

Conduit to Cable Tray Clamp

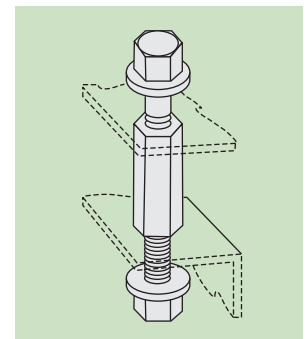
The Cope-GLAS Conduit to Cable Tray Clamp allows a smooth transition for electrical conduits to Cope-GLAS Cable Tray. The clamp is available in either polyester or vinyl ester and is adjustable to accommodate any entry angle. This clamp will work with all Cope-GLAS tray styles. To order, specify the correct conduit size. For vinyl ester, add the suffix "V" to the part number.



Conduit Size	Part Number	Conduit Size	Part Number
½"	CG-CCB-050	2"	CG-CCB-200
¾"	CG-CCB-075	2½"	CG-CCB-250
1"	CG-CCB-100	3"	CG-CCB-300
1¼"	CG-CCB-125	4"	CG-CCB-400
1½"	CG-CCB-150		

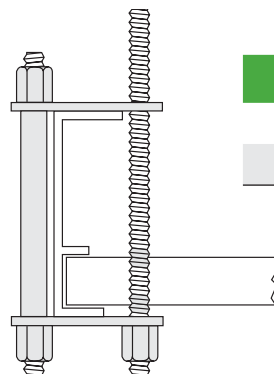
Cover Stand-Offs

Cover Stand-Offs secure cable tray cover to tray or fittings while providing a ventilation gap for cables. The S0200 is designed to be used with all "Z" and "E" profile cable trays. It is supplied with a threaded fiberglass stand-off and two ¾" diameter, non-metallic bolts (375PU-125). The S0200 requires field drilling. Five pairs of clamps are recommended per ten foot length of cable tray cover.



Tray Flange Hanger

The Cope-GLAS Flange Hanger is recommended when space requirements make conventional tray hanging and supporting methods impractical. Flange Hanger has a 375 lb. Load rating with a 2.0 safety factor. To specify vinyl ester, add suffix "V" to part number.



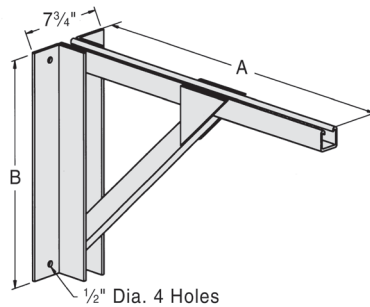
Part Number	Tray Style
RGFH1	Low Profile
RGFH2	E Profile

Accessories

Wall Support Brackets

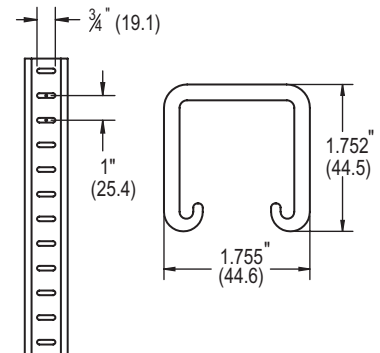
Constructed of Aickinstrut fiberglass components, Wall Support Brackets are an alternative tray hanging system. The Aickinstrut product line offers a complete line of fasteners that can be used with the wall brackets in many different tray clamping schemes. Installation guidelines for wall brackets are located in the Installation Procedures Section of this catalog.

To specify vinyl ester, add suffix "V" to part number.



Marine Rung

The marine rung may be specified for several tray components by adding MR to the part number. The marine rung is shown below.



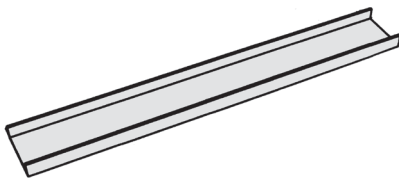
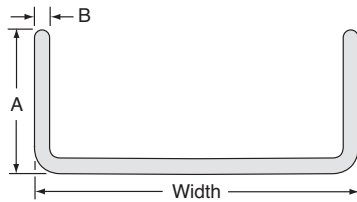
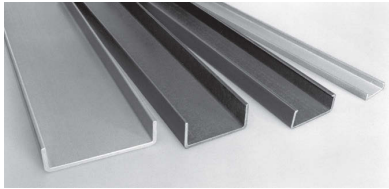
Part No.	Tray Width	Dim. A	Dim. B
CTB06A	06"	11" (279mm)	10" (254mm)
CTB09A	09"	14" (356mm)	12" (305mm)
CTB12A	12"	17" (432mm)	13" (330mm)
CTB18A	18"	23" (584mm)	16" (406mm)
CTB24A	24"	29" (737mm)	19" (483mm)
CTB30A	30"	35" (889mm)	22" (559mm)
CTB36A	36"	41" (1041mm)	25" (635mm)



Fiberglass Cable Tray & Channel

Fiberglass Channel

Fiberglass Channel



Fiberglass channel is designed to carry light wiring or tubing loads where a transition from cable tray to individual control points is required. All straight sections are offered in solid or punched construction and are supplied in ten and twenty foot lengths. Cope-GLAS Channel is available in polyester or vinyl ester resin. Contact factory for vinyl ester channel pricing. Channel fittings are supplied completely assembled from the factory. Special channel fittings that are not standard catalog items are available upon request. Channel splice plates and fasteners are separate order items.

Solid and Punched Straight Channel (10ft. & 20ft. Length)

Covers	Solid	Punched*	Width	"A"	"B"
C2-SL10	CH2-(L)	-Not Avail-	2" (51mm)	1 13/16" (31mm)	1/8" (3mm)
C3-SL10	CH3-(L)	CH3-(L)P	3" (76mm)	7/8" (22mm)	1/4" (6mm)
C4-SL10	CH4-(L)	CH4-(L)P	4" (102 mm)	1 3/8" (35mm)	3/16" (5mm)
C6-SL10	CH6-(L)	CH6-(L)P	6" (152mm)	1 5/8" (41mm)	1/4" (6mm)
C8-SL10	CH8-(L)	CH8-(L)P	8" (203mm)	2 1/16" (56mm)	1/4" (6mm)

*Punched channel consists of two rows of 1/2" diameter holes on 12" centers.

Channel Fittings [CH]

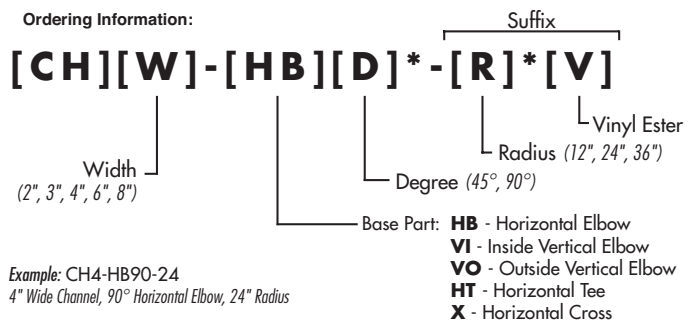
Solid and punched Channel Fittings are available for all channel widths except 2" (2" punched channel fittings are not available). All fittings are preassembled and do not include splice plates and hardware. Contact factory for dimensional information on 45° Channel Fitting bends.

Unless specified otherwise, smooth radius channel fittings will be supplied wherever possible for all 4" (102mm) and 6" (152mm) widths.

Ordering Information

To create a part number, first insert the fitting type from key shown below. Then substitute the appropriate number for "W", the desired radius for "R" and the degree of bend for "D". Add a "P" suffix to the "W" designation to

specify punched channel fittings. Channel Fittings are available in polyester or vinyl ester resin. Polyester is standard; to specify vinyl ester resin, add the suffix "V" to the part number.



* Radius and degree designations do not apply to tees and crosses.

Note: Connector plates and hardware are not included and must be ordered separately.

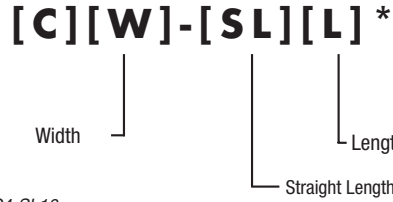
Fiberglass Channel

Covers are used where cable protection is necessary or desired. Covers are available in polyester or vinyl ester resin and are offered in ten foot lengths. To specify vinyl ester resin, add the suffix "V" to the part number.



Straight Covers

Cover Ordering Information:

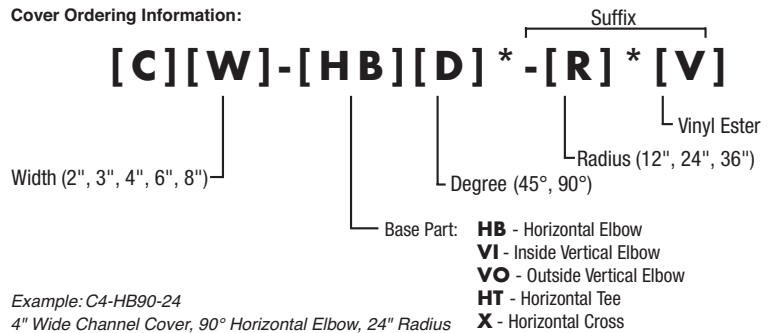


Example: C4-SL10
4" Wide Channel Cover, Straight Length, 10' Long

Note: Connector plates and hardware are not included and must be ordered separately.

Fitting Covers

Cover Ordering Information:

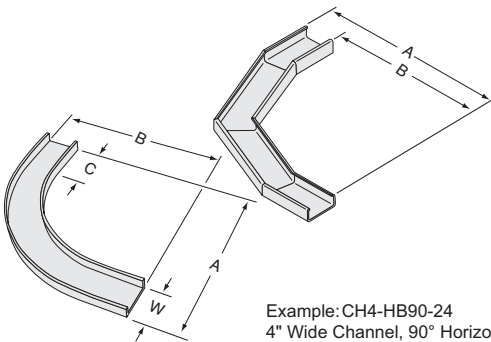


Example: C4-HB90-24
4" Wide Channel Cover, 90° Horizontal Elbow, 24" Radius

* Radius and degree designations do not apply to tees and crosses.

Note: Connector plates and hardware are not included and must be ordered separately.

Horizontal Elbows [HB]



Example: CH4-HB90-24
4" Wide Channel, 90° Horizontal Elbow, 24" Radius

Mitered Radius Dimensions

Radius	A	B
12" (305mm)	17" (432mm)+W	17" (432mm)
24" (610mm)	29" (737mm)+W	29" (737mm)
36" (914mm)	41" (1041mm)+W	41" (1041mm)

Smooth Radius (Available only in 4" and 6" widths) Dimensions

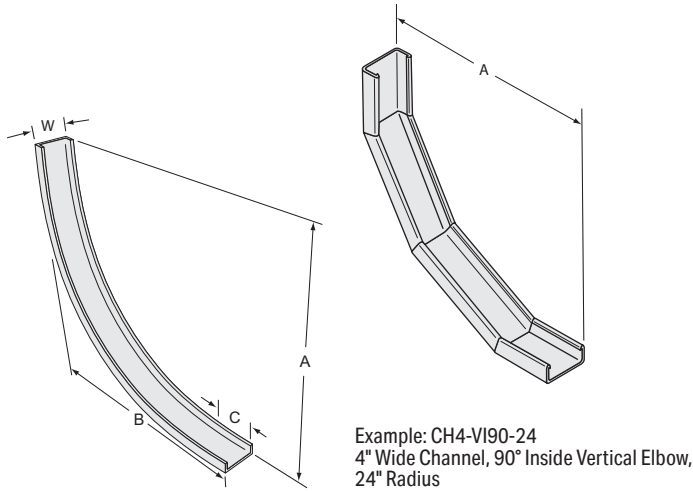
Radius	W	A or B	C (straight)
12" (305mm)	4"	20" (508mm)	5"
24" (610mm)	(102mm)	32" (813mm)	(127mm)
12" (305mm)	6"		
24" (610mm)	(152mm)		



Fiberglass Cable Tray & Channel

Fiberglass Channel

Inside Vertical Elbow [VI]



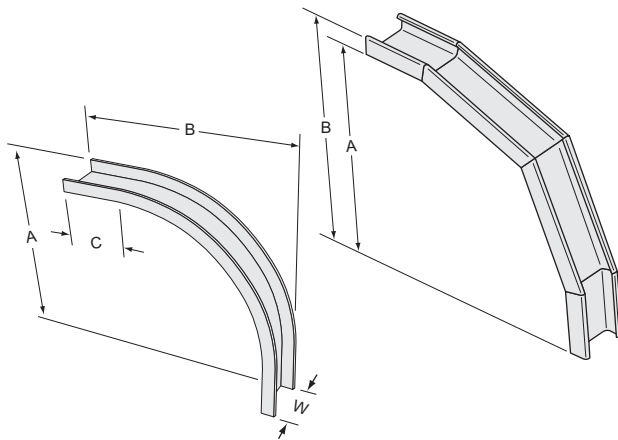
Mitered Radius Dimensions

Radius	A
12" (305mm)	17" (432mm)
24" (610mm)	29" (737mm)
36" (914mm)	41" (1041mm)

Smooth Radius (Available only in 4" & 6" widths)

Radius	W	A or B	C (Straight)
12" (305mm)	4" (102mm)	29½" (740mm)	5" (127mm)
24" (610mm)	6" (152mm)		

Outside Vertical Elbow [VO]



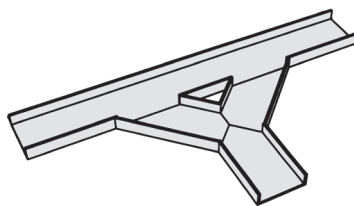
Mitered Radius Dimensions

Radius	A	B
12" (305mm)	17" (432mm)	17" (432mm) + Flange Height
24" (610mm)	29" (737mm)	29" (737mm) + Flange Height
36" (914mm)	41" (1041mm)	41" (1041mm) + Flange Height

Smooth Radius (Available only in 4" widths)

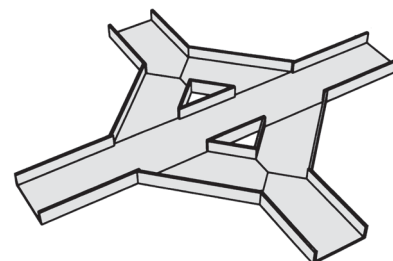
Radius	Channel Width	A or B	C (Straight)
12" (305mm)	4" (102mm)	18½" (460mm)	5" (127mm)
24" (610mm)	6" (152mm)		

Horizontal Tee [HT]



Horizontal Tees and Crosses are available as part of the Cope-GLAS Channel System. Contact factory for dimensional information.

Horizontal Cross [X]



Example: CH4-X
4" Wide Channel, Horizontal Cross

Fiberglass Channel - Channel Splice Plates

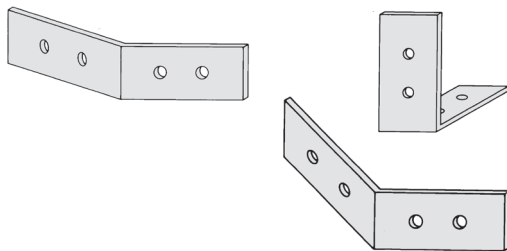
Channel splice plates are available in seven styles and are made from polyester or vinyl ester resin. All splice plates are pre-drilled and do not include assembly fasteners.

Straight Splice Plates [CHSP]



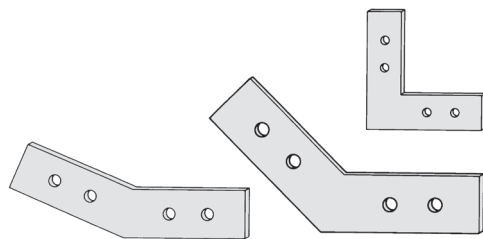
Channel Width	Part Number
2"	CHSP
3"	CHSP
4"	CHSP
6"	CHSP
8"	CHSP

Horizontal Elbow Splice Plates [SPH]



Channel Width	Part Numbers for Given Angle		
	90°	45°	22½°
2"	CHSPH90	CHSPH45	CHSPH22
3"	CHSPH90	CHSPH45	CHSPH22
4"	CHSPH90	CHSPH45	CHSPH22
6"	CHSPH90	CHSPH45	CHSPH22
8"	CHSPH90	CHSPH45	CHSPH22

Vertical Elbow Splice Plates [SPV]



Channel Width	Part Numbers for Given Angle		
	90°	45°	22½°
2"	CHSPV90	CHSPV45	CHSPV22
3"	CHSPV90	CHSPV45	CHSPV22
4"	CHSPV90	CHSPV45	CHSPV22
6"	CHSPV90	CHSPV45	CHSPV22
8"	CHSPV90	CHSPV45	CHSPV22

Channel Splice Plate Hardware

Part Number: 252075

Assembly hardware sets include:

- (1) 316 stainless steel ¼"-20 x ¾" bolt
- (1) 316 stainless steel ¼"-20 nut
- (2) 316 stainless steel flat washers

Assembly hardware is sold individually and not provided with channel straight sections or fittings. Four sets are required for each splice plate.

Note: (1) splice plate + hardware needed per piece of channel





Table of Contents

Aickinstrut System

Introduction215

Technical Information

Fabrication 216
 Materials..... 216
 Temperature Ranges.....217
 Typical Properties 218
 Aickinstrut Specifications..... 220
 Chemical Resistance.....222

Channel Framing

Channel Framing224
 Concrete Embedment Channel225
 SST Channel225
 Channel Profiles226
 Channel Loading.....228

Channel Framing Accessories

Channel Fittings232
 Post Bases236

Pipe Clamps

Aickinclamp Adjustable Pipe Clamps237
 Rigid Pipe Clamps238
 Two-Hole Pipe Straps.....239
 U-Bolts 240
 Channel Spacers 241
 Channel Capping Strip.....241
 Channel End Cap.....241

Fasteners

Fiberfast Bolts242
 Vinyl Ester Square Head Bolts243
 Fiberfast Hex Nuts.....243
 Vinyl Ester Square Nuts244
 Flat Washers244
 Channel Nuts.....245
 Saddle Clips245
 Stop-Lock Assemblies.....246

Pipe Hangers

Clevis Hangers247

Pipe Hanging Accessories

Beam Clamps248
 Beam Clamp Clips.....248
 Threaded Rod.....249
 Channel Hanger249

Pipe Supports

Power-Racks Stanchions 250
 Wall Bracket251

Instrument & Pipe Stands

Heavy Duty Post Base251

AICKINSHAPE

Introduction252

Structural Shapes

Structural Shapes.....252



Aickinstrut

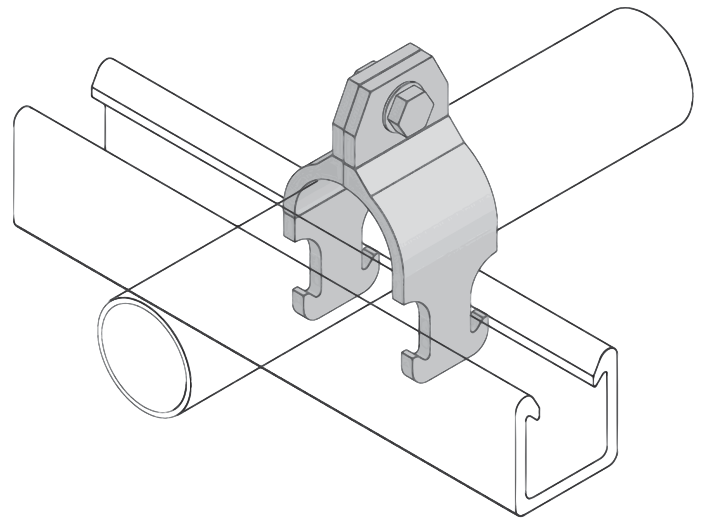
Introduction

Aickinstrut Fiberglass Strut is the most widely used and accepted nonmetallic strut support system in the world because it is the most complete quality line of nonmetallic accessories, fasteners, hangers, pipe clamps and channels available. Aickinstrut is a versatile, high-strength product that has been successfully used in thousands of applications worldwide. Some of those applications include wastewater treatment, refineries, chemical plants, marinas, pulp and paper, desalination facilities, theme parks, aquariums and underground vaults.

Made from entirely nonmetallic, corrosion resistant resins, Aickinstrut can be used in demanding environments where steel strut systems have traditionally failed. Its lightweight components can be installed quickly and easily using standard metal working tools. All Aickinstrut parts incorporate the highest quality materials to provide superior chemical resistance, strength, flame resistance and ultraviolet protection.

Because Aickinstrut manufactures a complete corrosion resistant strut support system, the customer has the benefit of purchasing all of these items from a single source, thereby minimizing start up and delivery delays.

Aickinstrut stands ready to provide assistance through its network of distributors and sales representatives.



Technical Information

Aickinstrut Fabrication

The installation of fiberglass channel and accessories is similar to the installation of metallic channel and accessories. All standard installation practices and procedures apply. In general, special handling is not required. Fabrication of Aickinstrut components requires just three simple operations: cutting, drilling and sealing as described below.

- **Cutting** – Cutting can be accomplished with a wide variety of saws. Hand held saws, such as hack saws (24 to 32 teeth per inch) are suitable when a few number of cuts are required. For frequent cutting, a circular power saw with a carbide-tipped masonry blade yields the best results and the greatest number of cuts. When using a power saw, dust filter masks, gloves and long sleeve clothing should be worn.
- **Drilling** – Any standard twist bit, even when used with battery-powered drills, will work well. Carbide-tipped drill bits are recommended.

LABOR SAVINGS

Aickinstrut fiberglass structural members can be cut and drilled at a much faster rate than steel. Typically, fiberglass can be fabricated in less than half the time. As a result, substantial labor savings will be realized. Also, Aickinstrut products average one-third the weight of their steel counterparts, making them much easier to handle on the job site.

RELATIVE MATERIAL COSTS

Aickinstrut materials are advantageously priced relative to specialty metals traditionally used in corrosive environments. Aickinstrut, even though slightly more expensive than pre-galvanized channel, can be used with the knowledge that it will not have to be maintained regularly or replaced after a brief time. Should pre-galvanized channel have to be replaced once, its cost far outweighs the expense of doing the initial installation with Aickinstrut.

MATERIAL

The finished Aickinstrut application will utilize a combination of materials from the following resin families:

Material Code	Material
E	PVC (extruded)
P	Polyester (pultruded)
V	Vinyl ester (pultruded)
PU	Polyurethane (injection molded)
PP	Polypropylene (injection molded)
N	Nylon (injection molded)

The ability of each material to handle high and low temperatures, chemical exposures and static loads is covered in each of the following sections. By using these criteria, you will be able to select the optimal Aickinstrut Channel, Fittings and Accessories for your particular applications.



Technical Information



OPERATING ENVIRONMENT

In order to design an Aickinstrut system for your application, consideration should be given to the maximum operating conditions. These “worst case” conditions will determine which type of Aickinstrut materials are best suited for your application. The three “worst case” operating conditions to consider are:

- Temperature
- Chemical Environment
- Loading

Temperature Ranges – Aickinstrut is supplied in six different materials covering distinct temperature ranges. Materials should be chosen which meet or exceed the minimum and maximum temperatures for your applications.

Material Code	Low Temperature	High Temperature
E	-25°F	130°F
P	-35°F	200°F
V	-35°F	200°F
PU	-40°F	140°F
PP	-30°F	150°F
N	-20°F	150°F

The temperature ranges indicated are meant to be used only as a general guideline. Continual exposure to elevated temperatures reduces the strength properties of plastics and glass reinforced fiberglass. Actual resin test data confirms that a 50% reduction in strength occurs at the extreme high temperature levels.

Chemical Resistance – Each resin family has its own specifications regarding its performance against corrosion resistance. Use the following chart on pages 222-223 to determine which Aickinstrut material system will provide the best performance for your particular application. The results in the chart are based upon immersion for a 24 hour period. This is typically the “worst case” exposure to corrosion. Less severe contact such as spills, splashes and vapor condensate will exceed the performance results listed in the table.

Loading – Channel loading is defined on pages 228 to 230. Additional loading and design limitations for fittings and accessories are described in the appropriate section for that part.

Technical Information

The Pultrusion Process

The pultruded structural component is made by reinforcing a polymer resin (usually polyester or vinyl ester resin) with multiple strands of glass filament and alternating layers of glass mat.

The glass is drawn through the liquid resin, which coats and saturates the fibers. The combination of resin and glass is then continuously guided and pulled (pultruded) through a heated die that determines the shape of the component.

In the die, the resin is cured to form a permanent, reinforced part which can be cut to a specific length. Since the hardened fiberglass pultrusion is reinforced with an internal arrangement of permanently bonded continuous glass fibers, it possesses great strength. In addition to strength, pultruded fiberglass components exhibit exceptional corrosion resistance. This attribute makes fiberglass the material of choice for many harsh industrial applications.

Resin Systems

Polyester and vinyl ester resin systems are available. The vinyl ester resin system is somewhat stronger and is applied in severe corrosive applications.

Both resin systems are flame retardant, conforming to ASTM E84, Class 1 flame rating and are self extinguishing per the requirements of UL94V-0.

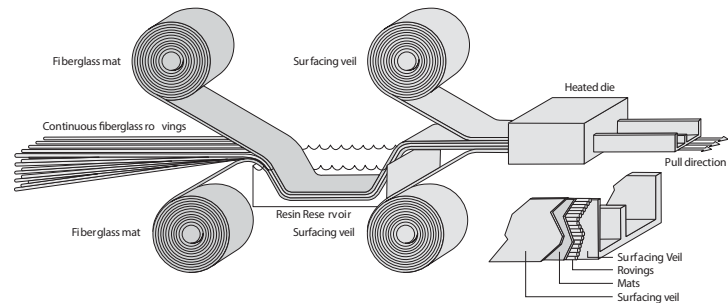
Consult the corrosion resistance guide on page 222 - 223 to determine the correct resin system for your application.

Aickinstrut reserves the right to make specification changes without notice. While every effort has been made to assure the accuracy of information contained in this catalog at the time of publication, we cannot accept responsibility for inaccuracies resulting from undetected errors or omissions.

Typical Properties	Test Method	Direction	Unit	Typical Value Polyester	Typical Value Vinyl Ester
Mechanical					
Ultimate Tensile Strength	ASTM D-638	Longitudinal	PSI	30,000	35,000
	ASTM D-638	Transverse	PSI	7,000	10,000
Tensile Modulus	ASTM D-638	Longitudinal	PSI	2.5 x 10 ⁶	3.0 x 10 ⁶
	ASTM D-638	Transverse	PSI	0.8 x 10 ⁶	1.0 x 10 ⁶
Ultimate Compressive Strength	ASTM D-695	Longitudinal	PSI	30,000	35,000
	ASTM D-695	Transverse	PSI	15,000	20,000
Compressive Modulus	ASTM D-695	Longitudinal	PSI	2.5 x 10 ⁶	2.5 x 10 ⁶
	ASTM D-695	Transverse	PSI	1.0 x 10 ⁶	1.2 x 10 ⁶
Ultimate Flexural Strength	ASTM D-790	Longitudinal	PSI	30,000	35,000
	ASTM D-790	Transverse	PSI	10,000	14,000
Flexural Modulus	ASTM D-790	Longitudinal	PSI	1.6 x 10 ⁶	2.0 x 10 ⁶
	ASTM D-790	Transverse	PSI	0.8 x 10 ⁶	1.0 x 10 ⁶
Shear Strength Short Beam	ASTM D-2344	Longitudinal or Transverse	PSI	5500	7000
			PSI	5500	6000
Impact Strength-Izod	ASTM D-256	Longitudinal	ft.-lb./in.	25	30
		Transverse	ft.-lb./in.	4	5
Hardness-Barcol	ASTM D-2583	Perpendicular	—	50	50



Technical Information



Glass Roving and Mat Reinforced Polyester and Vinyl Ester Fiberglass Components

Typical Properties	Test Method	Direction	Unit	Typical Value Polyester	Typical Value Vinyl Ester
Electrical					
Electric Strength Short Time-in oil	ASTM D-149	Perpendicular	Volts/mil.	200	200
		Parallel	KV/in.	35	35
Dielectric Constant	ASTM D-150	Perpendicular	—	5	5
Dissipation Factor	ASTM D-150	Perpendicular	—	0.03	0.03
Arc Resistance	ASTM D-495	Longitudinal or Transverse	Seconds	80	120
			Seconds	80	120
Other					
Thermal Coefficient of Expansion	ASTM D-696	Longitudinal	in./in./°F	5 x 10 ⁻⁶	5 x 10 ⁻⁶
Thermal Conductivity		Longitudinal	BTU/Hr. sq. ft./in./°F	4.0	4.0
Water Absorption 24 hours	ASTM D-570	Longitudinal	%	1	1
Density	ASTM D-792	Longitudinal	lbs./cu.in.	0.062	0.062
Color (Standard)				Dark Gray	Beige
Flammability	UL94		Classification:	V-0	V-0
Flammability	ASTME84		Rating:	25	25

Aickinstrut Fiberglass Threaded Rod Material Properties Threaded rod is a proprietary combination of fiberglass and Class I vinyl ester flame retardant resin.

Aickinstrut Fiberglass Threaded Rod Material Properties

Threaded rod is a proprietary combination of fiberglass and Class I vinyl ester flame retardant resin.			
Properties	¾ -16 UNC	½ -13 UNC	⅝ -11 UNC
Thread shear strength using fiberglass nut in tensile (lbs.)	1,250	2,500	3,800
Transverse shear on threaded rod-double shear ASTM-B-565 (load lb.)	4,200	7,400	11,600
Transverse shear on threaded rod-single shear (load lb.)	1,600	2,600	3,800
Compressive strength-longitudinal ASTM-D-695 (psi)	55,000	55,000	55,000
Flexural strength ASTM-D-790 (psi)	60,000	60,000	60,000
Flexural modulus ASTM-D-790 (psi x 10 ⁶)	2.0 x 10 ⁶	2.0 x 10 ⁶	2.0 x 10 ⁶
Torque strength using fiberglass nut lubricated with SAE IOW30 motor oil (ft.-lbs.)	8	15	33
Dielectric strength ASTM-D-149 (kv/in.)	40	40	40
Water absorption 24 hour immersion-threaded ASTM-D-570 (%)	1	1	1
Coefficient of thermal expansion-longitudinal (in./in./°F)	5 x 10 ⁻⁶	5 x 10 ⁻⁶	5 x 10 ⁻⁶
Max recommended operation temp, based on 50% retention of ultimate thread shear strength (°F)	200	200	200
Stud weight (lb./ft.)	.076	.129	.209
Flammability	Self extinguishing per UL94V-0		

Aickinstrut Specifications

1.0 Scope

1.1 This specification covers the requirements for the Aickinstrut Nonmetallic Channel Framing System.

2.0 Material

2.1 FRP channel shall be of pultruded glass reinforced polyester or vinyl ester resin having the physical property values listed in this catalog.

2.2 PVC channel shall be of extruded polyvinyl chloride having the physical property values listed in this catalog.

2.3 Some accessories shall be of injection molded, 40% long glass fiber reinforced polyurethane, polypropylene or nylon.

3.0 Composition

3.1 Glass reinforced channel shall have a synthetic surfacing veil applied on exterior surfaces to improve weatherability and inhibit ultraviolet degradation.

3.2 PVC channel shall be manufactured from a UV stabilized resin and incorporate dark gray pigment to improve weatherability and inhibit ultraviolet degradation.

4.0 Structural Design

4.1 Channel shall incorporate Aickinstrut's patented flange profile design which allows full and positive interlocking contact of channel accessories and prohibits premature flange failure from torqued accessories.

4.2 Channel profile dimensions shall be:

$1\frac{5}{8}'' \times 1\frac{5}{8}'' \times \frac{3}{16}''$

$1\frac{1}{2}'' \times 1\frac{1}{2}'' \times \frac{3}{16}''$

$1\frac{1}{2}'' \times 1\frac{1}{8}'' \times \frac{3}{16}''$

4.3 All $1\frac{5}{8}'' \times 1\frac{5}{8}''$ channel profiles shall have a minimum pull out resistance of 1,000 pounds when load is applied over a $\frac{3}{8}''$ long section of the inside flanges.

4.4 Channel section lengths shall be supplied in 10' or 20' lengths ($\pm 1/8''$).

4.5 Universal Pipe Clamps shall have full interlocking contact with interior channel flanges to maximize pull-out resistance and be adjustable to accommodate a minimum $\frac{3}{4}''$ variance in piping or conduit O.D. sizes.



Aickinstrut Specifications

**5.0 Standards**

5.1 Glass reinforced and PVC channels covered in this specification shall have a flame spread rating of 25 or less when tested per ASTM E84 and meet the requirements of UL 94V0 thereby qualifying them as Class 1 material in the Uniform Building Code.

5.2 Glass reinforced channels covered in this specification shall comply with the requirements of ASTM D 3917 and ASTM D 4385 which govern the dimensional tolerance and visual defects of pultruded shapes.

6.0 GENERAL

6.1 Aickinstrut Nonmetallic Channel Framing shall be furnished as a system which includes all the necessary fasteners, channel splice plates, brackets, sealants, hangers, pipe clamps, etc.

6.2 Nonmetallic fasteners shall be manufactured from long glass fiber reinforced polyurethane to ensure maximum strength and corrosion resistance.

6.3 All components of the Aickinstrut Channel Framing System shall be nonmetallic except where type 316 stainless steel hardware is used as part of the assembly.

6.4 Aickinstrut is manufactured by Aickinstrut, a subsidiary of Atkore.

6.5 The manufacturer shall not have had less than 10 years experience in manufacturing strut systems.

6.6 Most products are manufactured in the United States of America. Some items are outsourced where deemed necessary.

Chemical Compatibility Table

Chemical	Series E (Rigid PVC) 70°-160°F		Series P (Poly/Glass) 70°-160°F		Series V (Vinyl/Glass) 70°-160°F		Series K (PVDF) 70°-160°F		Series PU (Polyurethane) 70°-160°F		Series N (Nylon) 70°-160°F	
Acetic Acid, Up to 10%	R	R	R	R	R	R	R	R	R	-	NR	NR
Acetic Acid, Up to 50%	R	R	R	R	R	R	R	R	R	-	NR	NR
Acetone, Up to 10%	NR	NR	NR	NR	NR	NR	NR	NR	R	-	R	R
Aluminum Hydroxide	R	R	R	R	R	R	R	R	R	-	NR	NR
Ammonium Hydroxide (Aqueous Ammonia), Up to 5%	R	R	NR	NR	R	R	R	R	R	-	-	-
Ammonium Hydroxide, Up to 10%	R	R	NR	NR	R	150°	R	R	R	-	-	-
Ammonium Hydroxide, Up to 20%	R	R	NR	NR	R	150°	R	R	R	-	-	-
Ammonium Nitrate	R	NR	R	R	R	R	R	R	R	-	-	-
Ammonium Phosphate	R	R	R	NR	R	R	R	R	R	-	-	-
Ammonium Sulfide, saturated	R	R	NR	NR	R	120°	R	R	R	-	-	-
Aqua Regia, fumes	NR	NR	NR	NR	R	150°	R	R	NR	-	-	-
Benzene NR NR	NR	NR	NR	NR	NR	NR	NR	R	R	R	R	R
Benzoic Acid R	R	R	R	R	R	R	R	R	R	-	-	-
Bromine, wet gas	R	NR	NR	NR	R	100°	R	R	-	-	-	-
Butylene Glycol, Up to 100%	R	R	R	R	R	R	R	R	R	-	R	R
Butyric Acid, Up to 50%	NR	NR	R	R	R	R	R	R	R	-	-	-
Calcium Hydroxide R	R	R	R	NR	R	R	R	R	R	-	-	-
Calcium Hypochlorite R	R	R	R	NR	R	R	R	R	R	-	NR	NR
Chlorine, Dry Gas	NR	NR	NR	NR	R	R	R	R	-	-	-	-
Chlorine, Wet Gas	NR	NR	NR	NR	R	R	R	R	-	-	-	-
Chlorine, Liquid NR	NR	NR	NR	NR	NR	NR	R	R	-	-	-	-
Chlorine, Water NR	NR	NR	R	R	R	R	R	R	R	-	NR	NR
Chromic Acid, Up to 5%	R	R	NR	NR	R	R	R	R	-	-	R	R
Copper Chloride	R	R	R	R	R	R	R	R	R	-	-	-
Copper Cyanide	R	R	R	NR	R	R	R	R	R	-	-	-
Copper Fluoride	R	R	R	NR	R	R	R	R	R	-	-	-
Copper Nitrate	R	R	R	R	R	R	R	R	R	-	-	-
Copper Sulfate	R	R	R	R	R	R	R	R	R	-	-	-
Dechlorinated Brine Storage	R	R	-	-	R	R	R	R	R	-	-	-
Esters, Fatty Acid	NR	NR	R	R	R	R	R	R	R	-	-	-
Ferric Chloride	R	R	R	R	R	R	R	R	R	-	-	-
Ferrous Chloride	R	R	R	R	R	R	R	R	R	-	-	-
Fluoboric Acid	R	R	R	120°	R	R	R	R	-	-	-	-
Fluosilicic Acid, Up to 10%	NR	NR	NR	NR	R	R	R	R	-	-	NR	NR
Fluosilicic Acid, Up to 32%	NR	NR	NR	NR	R	100°	R	R	-	-	-	-
Formic Acid, Up to 10%	R	R	NR	NR	R	R	R	R	R	-	NR	NR
Formic Acid, Up to 50%	R	R	NR	NR	R	100°	R	R	R	-	-	-
Gasoline, Aviation	R	NR	R	NR	R	R	R	R	R	-	-	-
Green Liquor, Pulp Mill	R	R	-	-	R	R	R	R	-	-	-	-
Hydrochloric Acid Up to 15%	R	R	R	NR	R	R	R	R	R	-	-	-
Hydrochloric Acid Up to 37%	R	R	R	NR	R	R	R	R	R	-	-	-
Hydrofluoric Acid, Up to 10%	R	R	NR	NR	R	150°	R	R	-	-	-	-
Hydrofluoric Acid, Up to 20%	R	NR	NR	NR	R	100°	R	R	-	-	-	-
Hydrogen Chloride, Wet Gas	NR	NR	R	NR	R	R	R	R	NR	-	-	-
Hydrogen Sulfide, Wet Gas	R	R	R	NR	R	R	R	R	R	-	-	-

Legend: "NR" indicates "Not Recommended" for use; "R" indicates "Recommended"; "-" indicates no information available



Chemical Compatibility Table

Chemical	Series E (Rigid PVC) 70°-160°F		Series P (Poly/Glass) 70°-160°F		Series V (Vinyl/Glass) 70°-160°F		Series K (PVDF) 70°-160°F		Series PU (Polyurethane) 70°-160°F		Series N (Nylon) 70°-160°F	
	R	R	R	NR	R	R	R	R	R	-	-	-
Lactic Acid	R	R	R	NR	R	R	R	R	R	-	-	-
Lead Nitrate	R	R	-	-	R	R	R	R	R	-	-	-
Magnesium Hydroxide	R	R	NR	NR	R	R	R	R	R	-	R	R
Nickel Sulfate, Low pH	R	R	NR	NR	R	R	R	R	R	-	-	-
Nickel Sulfate, High pH	R	R	NR	NR	R	R	R	R	R	-	-	-
Nitric Acid, Up to 5%	R	R	NR	NR	R	150°	R	R	R	-	-	-
Nitric Acid, Up to 35%	R	R	NR	NR	R	150°	R	R	R	-	-	-
Nitric Acid, Vapor	R	R	NR	NR	R	R	R	R	-	-	-	-
Perchloric Acid, Up to 10%	NR	NR	NR	NR	R	150°	R	R	-	-	NR	NR
Pickling Liquids, 3-5% H2SO4	R	R	R	R	R	R	R	R	R	-	-	-
Phosphoric Acid	R	R	NR	NR	R	R	R	R	R	-	NR	NR
Phosphoric Acid, Super or Poly (115%, P20%)	R	R	NR	NR	R	R	R	R	-	-	-	-
Phosphoric Acid Vapor or Condensate	R	R	NR	NR	R	R	R	R	-	-	-	-
Potassium Chloride	R	R	R	R	R	R	R	R	R	-	-	-
Potassium Nitrate	R	R	R	R	R	R	R	R	R	-	-	-
Potassium Persulfate	R	R	NR	NR	R	R	R	R	R	-	-	-
Silver Cyanide, Up to 5%	R	R	NR	NR	R	R	R	R	R	-	-	-
Sodium Hydroxide, Up to 25%	R	R	NR	NR	R	150°	R	R	R	-	-	-
Sodium Hydroxide, up to 50%	R	R	NR	NR	R	180°	R	R	-	-	R	R
Sodium Hypochlorite, Up to 10%5	R	R	NR	NR	R	150°	R	R	R	-	NR	NR
Sodium Nitrate	R	R	R	R	R	R	R	R	R	-	-	-
Sodium Sulfate	R	R	R	NR	R	R	R	R	R	-	-	-
Sodium Sulfide	R	R	NR	NR	R	R	R	R	R	-	-	-
Sulfuric Acid, Up to 25%	R	R	R	R	R	R	R	R	R	-	NR	NR
Sulfuric Acid, Up to 50%	R	R	NR	NR	R	R	R	R	R	-	-	-
Sulfuric Acid, Up to 70%	R	R	NR	NR	R	R	R	R	R	-	NR	NR
Sulfuric Acid, Up to 75%	NR	NR	NR	NR	R	120°	R	R	-	-	NR	NR
Sulfuric Acid, Up to 80%	NR	NR	NR	NR	NR	NR	NR	NR	-	-	NR	NR
Sulfuric Acid, Vapor	R	R	R	NR	R	R	R	R	-	-	-	-
Trichlorethylene, Fumes	NR	NR	NR	NR	R	120°	R	R	NR	-	-	-
Trisodium Phosphate	R	R	R	NR	R	R	R	R	R	-	-	-
Urea R	R	R	R	NR	R	150°	R	R	R	-	R	R
Vegetable Oils	R	R	R	R	R	R	R	R	R	-	R	R
Vinegar R	R	R	R	R	R	R	R	R	R	R	R	R
White Liquor, Pulp Mill	R	R	-	-	R	R	R	R	-	-	-	-

Legend: "NR" indicates "Not Recommended" for use; "R" indicates "Recommended"; "-" indicates no information available

Beam Loading Conversion Table

Note: The recommendations contained in the table on pages 230-231 are made without guarantee of representation as to results. Since the actual use by others is beyond our control, no guarantee, expressed or implied, is made by Cope as to effects of such use or results to be obtained nor does Cope assume any liability arising out of the use by others of the products referenced in this table. Nor is the information herein to be construed as absolutely complete since additional information may be needed or desirable when particular or exceptional conditions or circumstances exist or because of applicable laws or government regulations. We suggest that you evaluate these recommendations and suggestions in your own laboratory prior to use. Our responsibility for claims arising from breach of warranty, negligence, or otherwise is limited to the purchase price of the material.

FEATURES

SWAGE

I-BEAM

TROF

EAGLE BASKET

CHANNEL

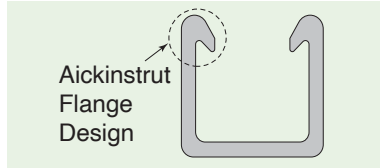
GLAS

AICKINSTRUT

DATA

Channel Framing

All Aickinstrut channels, except the SST series, incorporate a flange design which provides reliable fastening and interlocking of Aickinstrut components and accessories.



Channels are provided in standard lengths of 10' with longer lengths available upon request. Aickinstrut single channels come packaged in boxes of 100' while the double channels are packaged in boxes containing 40'.

Aickinstrut channel is available in 3 materials:

- Polyester (P material) - Gray
- Vinyl Ester (V material) - Beige
- PVC (E material) - Dark Gray

Polyester and Vinyl Ester Materials

The polyester and vinyl ester channels are manufactured from the pultrusion process. In this process, the component is made by reinforcing a polymer resin (polyester or vinyl ester) with multiple strands of glass filament, alternating layers of glass mat and UV resistant surfacing veils. The glass is drawn through the liquid resin, which coats and saturates the fibers. The combination of resin, glass and veil is then continuously guided and pulled (pultruded) through a heated die that determines the shape of the component.

In the die, the resin is cured to form a permanent, reinforced part which can be cut to a specific length. Since the hardened fiberglass pultrusion is reinforced with an internal arrangement of permanently bonded continuous glass fibers, it possesses great strength.

In addition, pultruded fiberglass components exhibit exceptional corrosion and fire resistance. These attributes make fiberglass the material of choice for many harsh industrial applications.

The polyester and vinyl ester channels are color coded. Polyester channels are colored gray and the vinyl ester channels are colored beige.

PVC Materials

The PVC channels are manufactured from the extrusion process. In this process, the component is made by a PVC resin mixture being continuously fed through a heated die that determines the shape of the component.

In the die, the resin is cured to form a permanent, extruded part that can be cut to a specific length. Unlike pultruded components, extruded components do not incorporate glass-reinforcement; consequently, they do not exhibit the same beam strength as their pultruded counterparts. PVC components, however, exhibit exceptional corrosion and fire resistance. These features make PVC channels an excellent alternative when excessive beam strength is not required. PVC channels are color coded dark gray.

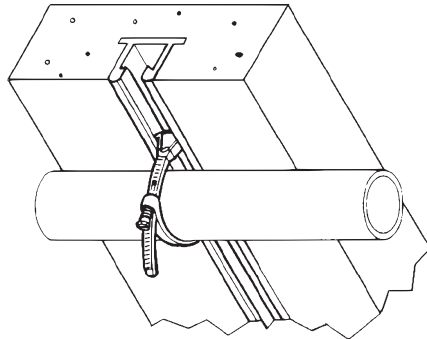
Channel Availability Chart

The following chart illustrates the availability of materials in the different channel profiles.

Channel Profile	Polyester (P) Vinyl Ester (V)	PVC (E)
Series 1000, 1200, 2000, 2200, 2300	X	X
Series 1100, 1300, 1500, 1600, 1700, 1800, 2000SST, 2100, 2100SST, 2200SST, 2300SST	X	N/A

Concrete Embedment Channel

In certain applications, it is necessary to embed a corrosion resistant channel into a new pouring of concrete. For these applications, Aickinstrut



concrete embedment channel is recommended. Aickinstrut embedment channel is available in three material types: PVC, polyester and vinyl ester. The PVC embedment channel is extruded as one piece while the polyester and vinyl ester embedment channel is a two piece bonded type design. The PVC embedment channel is available in the 1 5/8" profile while polyester and vinyl ester embedment channels are available in all three profiles (1 5/8", 1 1/2" & 1 1/8").

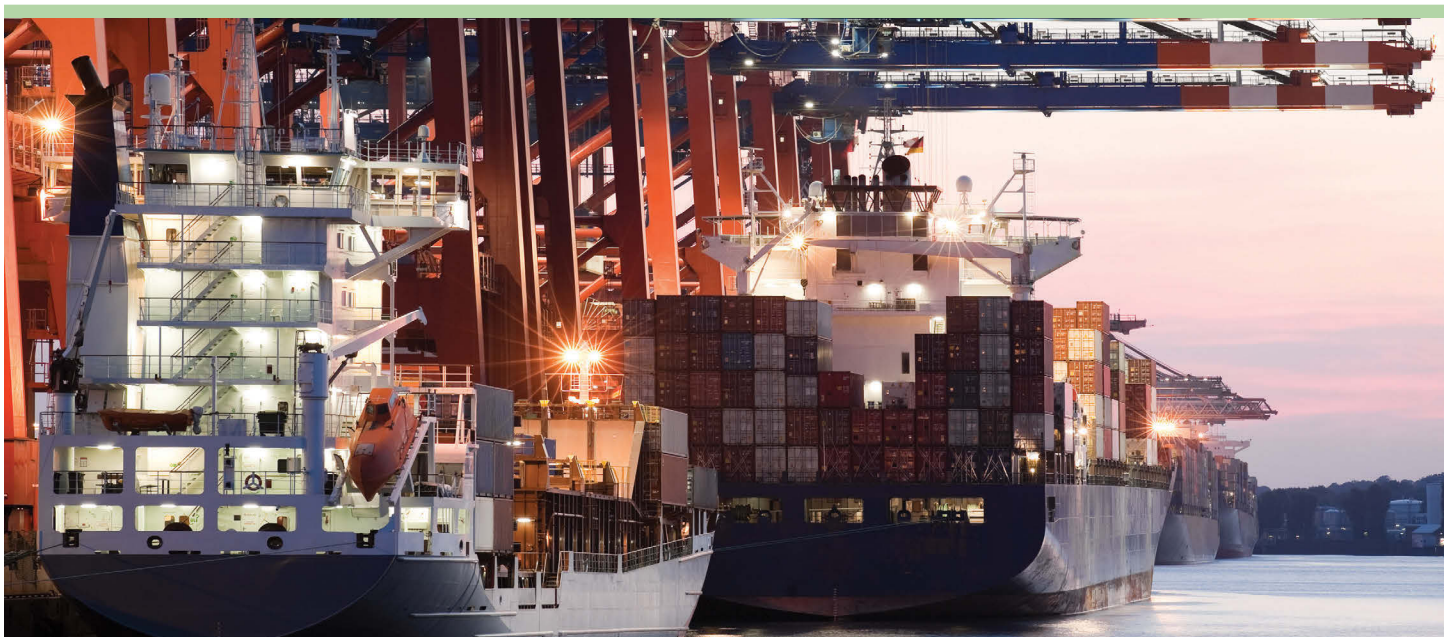
The embedment channel utilizes two continuous protruding flanges in the profile base to retain the channel in the concrete. Mounting the embedment channel flush with the concrete surface is a convenient way to secure piping, conduits or electrical enclosures to a wall or ceiling. The PVC embedment

channel is extremely high in strength. When embedded in 3,000 PSI concrete, the concrete will fail before the channel is pulled out. When field cuts are made, product must be sealed using acrylic enamel.

Aickinstrut SST Channel

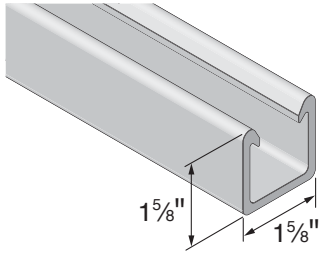
Aickinstrut SST Fiberglass Channel incorporates a standard channel profile that will accommodate metallic pipe straps and clamps. SST channel is available in polyester or vinyl ester resin. All standard styles (solid, slotted, concrete insert and back-to-back) are also available. Please contact the factory for loading information for the SST Channel.

Note: Aickinstrut SST Channel is not compatible with the Aickinstrut pipe clamps, channel nuts, and grooved fittings shown in this catalog. This profile is designed for use with metallic pipe straps and pipe clamps which are also available from Atkore. Please contact Metal Framing for pricing and availability.

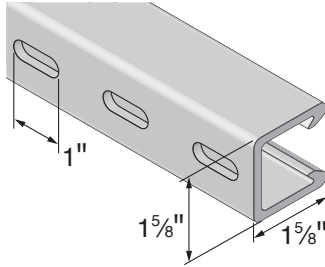


**Heavy Duty Channel -
Aickinstrut Profile**

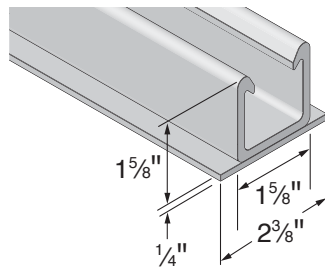
Standard
(20P-2000, 20V-2000, 20E-2000)



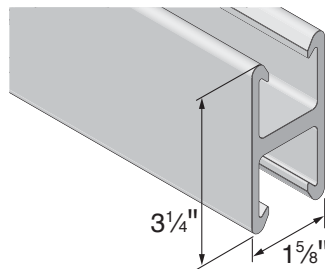
Slotted (1" x 3/8" Holes)
(20P-2200, 20V-2200, 20E-2200)



With Concrete Inserts
(20P-2300, 20V-2300, 20E-2300)

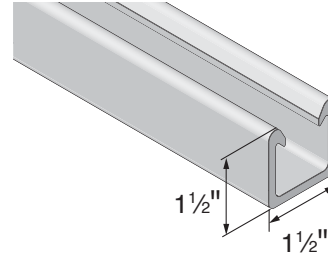


Back-to-Back
(20P-2100, 20V-2100)

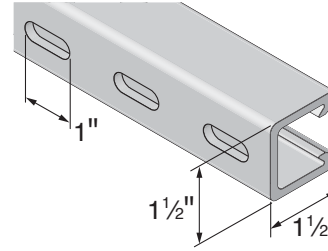


**Medium Duty Channel -
Aickinstrut Profile**

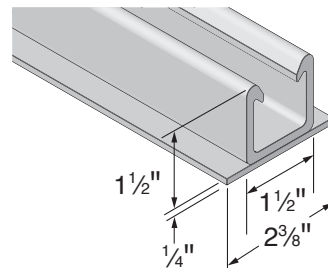
Standard
(20P-1500, 20V-1500)



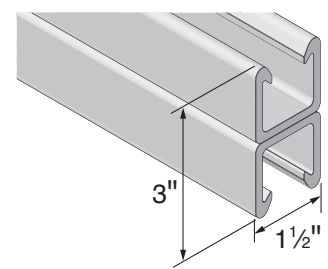
Slotted (1" x 3/8" Holes)
(20P-1700, 20V-1700)



With Concrete Inserts
(20P-1800, 20V-1800)



Back-to-Back
(20P-1600, 20V-1600)



Standard lengths of 10ft. To order 20ft lengths, add -20 to the end of the part number.

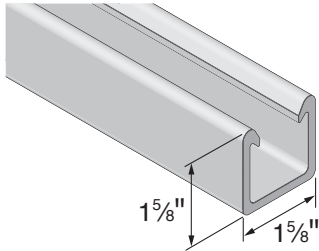


Aickinstrut

Light Duty Channel - Aickinstrut Profile

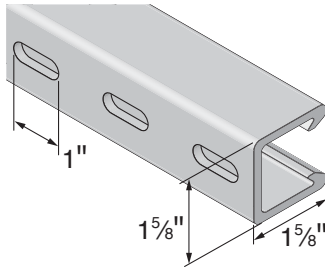
Standard

(20P-1000, 20V-1000, 20E-1000)



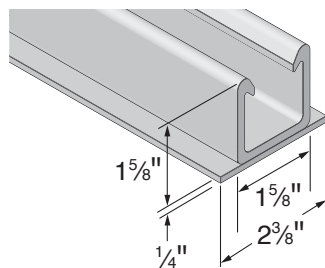
Slotted (1" x 3/8" Holes)

(20P-1200, 20V-1200, 20E-1200)



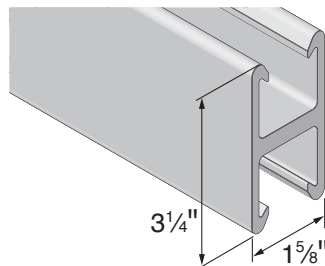
With Concrete Inserts

(20P-1300, 20V-1300)



Back-to-Back

(20P-1100, 20V-1100)

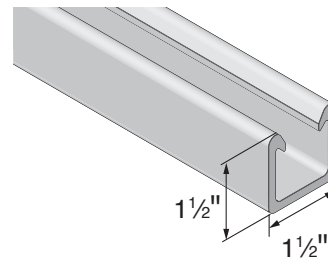


Standard lengths of 10ft. To order 20ft lengths, add -20 to the end of the part number.

Heavy Duty Channel - Standard Profile*

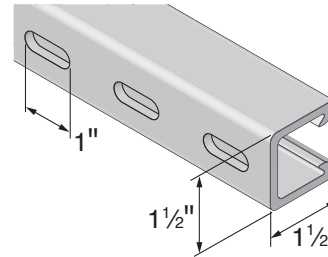
Standard

(20P-2000-SST, 20V-2000-SST)



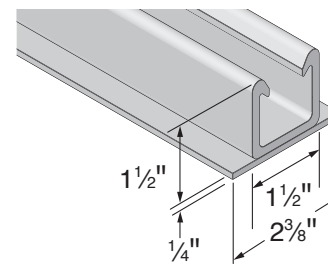
Slotted (1" x 3/8" Holes)

(20P-2200-SST, 20V-2200-SST)



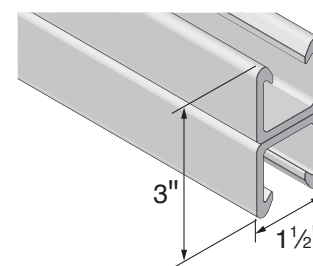
With Concrete Inserts

(20P-2300-SST, 20V-2300-SST)



Back-to-Back

(20P-2100-SST, 20V-2100-SST)



*Aickinstrut pipe clamps, pipe straps, etc. not compatible with Standard profile. For metallic accessories, refer to metal framing offering.

Channel Loading

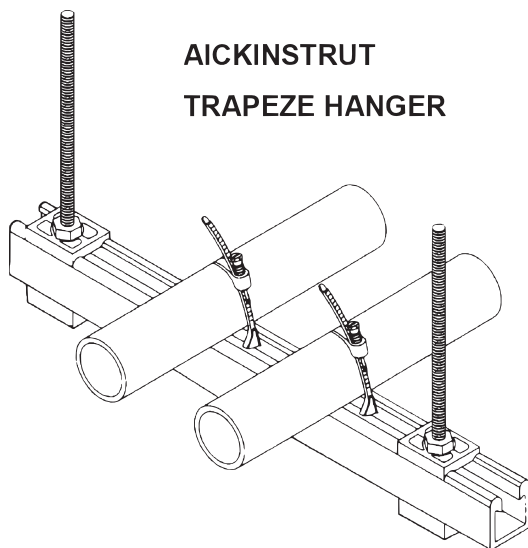
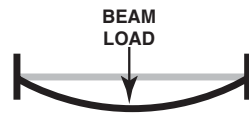
Channel loading generally occurs in one of the following modes:

- beam
- column
- flange

BEAM LOADING

Beam loading data reflects the maximum uniform load allowed when using the channel horizontally as in a trapeze hanger. Refer to the table on Page 230 for simple beam loading capacity of various channels. Use the beam loading conversion chart on page 228 to calculate loading capacity for other beam loading conditions. The Aickinstrut Trapeze hanger is an example of beam loading. To calculate the maximum allowable beam load for an Aickinstrut Trapeze hanger:

1. Measure the distance between the two threaded rod supports.
2. Using the length of the section hanger as the “beam”, refer to the appropriate profile size in the Beam Loading Chart to determine whether the deflection meets your requirements.



**AICKINSTRUT
TRAPEZE HANGER**

Beam Loading - PVC

The data listed in the Beam Loading Chart reflects testing conducted on Polyester (Type P) and Vinyl Ester (Type V) channels. PVC (Type E) material will differ from the Polyester/Vinyl Ester Beam Loading Chart. To obtain the beam loading for PVC channel, reduce the load as follows:

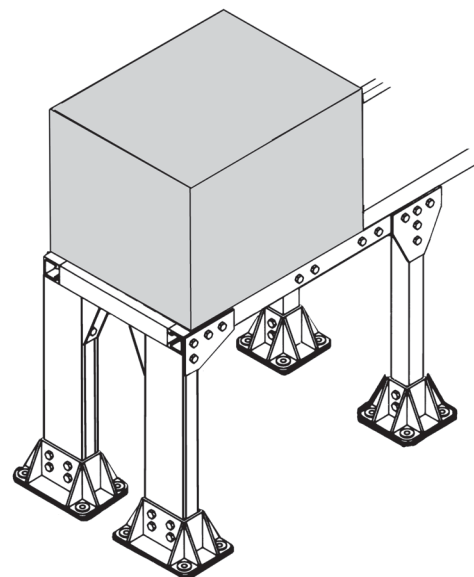
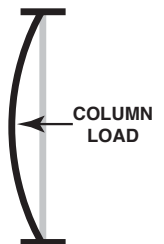
$$\text{PVC Beam Load} = \frac{(\text{Polyester/Vinyl Ester Beam Load})}{4}$$

Note: PVC is not recommended for lengths over 24".

COLUMN LOADING

Column loads are forces applied directly to the end of the channel. Refer to the table on Page 230 for column loading capacity of various channels.

An example of a typical column load would be the pressure exerted on a leg of an Aickinstrut Battery Rack.



Battery Rack

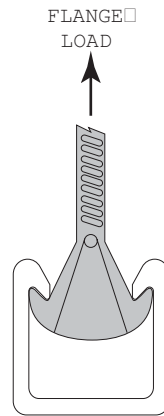


Aickinstrut

Channel Loading

FLANGE LOADING

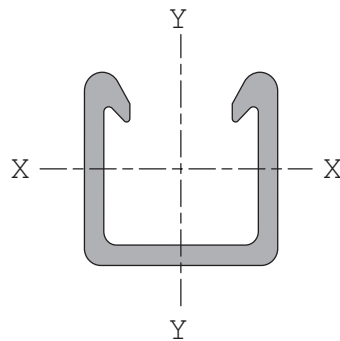
Pull-out strength is the channel's resistance to a clamp or fastener inserted under the flange and put under tension. For additional information concerning specific channels, materials and their pull-out strengths, refer to the channel flange pull-out chart on the right.



Flange Loading

Heavy Duty Channel	Pull-Out Strength*
20V-2000	449
20P-2000	360
20E-2000	260
Medium Duty Channel	Pull-Out Strength*
20V-1500	229
20P-1500	219
Light Duty Channel	Pull-Out Strength*
20E-1000	239
20P-1000	213
20V-1000	213

Section Properties



Section Number	Height	Width	Weight (lbs./ft.)	Area	X - X Axis				Y - Y Axis		
					I (in. ⁴)	R	C ¹	C ²	I (in. ⁴)	R	C
2000	1 ⁵ / ₈ "	1 ⁵ / ₈ "	0.82	1.06"	0.31	0.54"	0.7"	0.93"	0.42	0.63"	0.82"
2100	3 ¹ / ₂ "	1 ⁵ / ₈ "	1.64	2.12"	1.77	0.91"	1.63"	1.63"	0.85	0.63"	0.82"
1500	1 ¹ / ₂ "	1 ¹ / ₂ "	0.55	0.71"	0.19	0.52"	0.62"	0.88"	0.25	0.59"	0.75"
1600	3"	1 ¹ / ₂ "	1.1	1.42"	1.02	0.85"	1.5"	1.5"	0.49	0.59"	0.75"
1000	1 ¹ / ₈ "	1 ¹ / ₂ "	0.47	0.61"	0.1	0.4"	0.51"	0.62"	0.22	0.6"	0.75"
1100	2 ¹ / ₂ "	1 ¹ / ₂ "	0.94	1.22"	0.42	0.59"	1.13"	1.13"	0.44	0.6"	0.75"

Channel Loading

The multipliers shown in the beam loading conversion table reflect the adjustments to be made for a variety of beam loading conditions. The multipliers should be used in conjunction with the Beam Loading Chart.

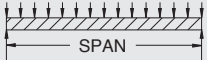

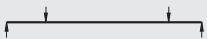
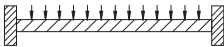
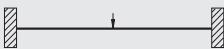



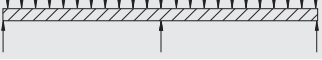

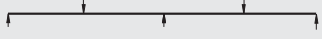
Example:

Determine load and deflection of a 30" 20P-2100 cantilever beam with a concentrated load on the end.

The values in the Beam Loading Chart are based on a simple beam with uniform loading. By using the Beam Loading Conversion Table, you will be able to estimate the maximum recommended loading and deflection for your particular application.

Solution:

1. From the load table on the next page, the maximum load for a 30" span is 2,224 lbs. and deflection for that load is 0.177".
2. Multiply by factors from the table below.
Load = 2,224 lbs. x 0.12 = 267 lbs.
Deflection = 0.177" x 3.20 = 0.566"
3. Thus, the 30" cantilever beam will support a maximum concentrated load of 267 lbs. on the end and that load will cause a 0.566" deflection.

Load And Support Condition		Load Factor	Deflection Factor
"1. Simple Beam, Uniform Load"		1.00	1.00
"2. Simple Beam, Concentrated Load at Center"		0.50	0.80
"3. Simple Beam, Two Equal Concentrated Loads at 1/4 pts"		1.00	1.10
"4. Beam Fixed at Both Ends, Uniform Load"		1.50	0.30
"5. Beam Fixed at Both Ends, Concentrated Load at Center"		1.00	0.40
"6. Cantilever Beam, Uniform Load"		0.25	2.40
"7. Cantilever Beam, Concentrated Load at End"		0.12	3.20
"8. Continuous Beam, Two Equal Spans, Uniform Load on One Span"		1.30	0.92
"9. Continuous Beam, Two Equal Spans, Uniform Load on Both Ends"		1.00	0.42
"10. Continuous Beam, Two Equal Spans, Concentrated Load at Center of One Span"		0.62	0.71
"11. Continuous Beam, Two Equal Spans, Concentrated Load at Center of Each Span"		0.67	0.48



Channel Loading

Polyester/Vinyl Ester Beam Loading Chart

Span	Part Number	Max. Uniform Beam Load (Safety Factor - 3:1)		Uniform Load at Defl. of $\frac{1}{360}$ Span		Maximum Column
		Load (lbs.)	Deflection (in.)	Load (lbs.)	Deflection (in.)	Load (lbs.)
12" Span	20P/V-2100	5,559	0.028	5,559	0.033	9,454
	20P/V-1600	4,836	0.043	3,778	0.033	7,007
	20P/V-1100	3,804	0.082	1,556	0.033	5,961
	20P/V-2000	3,561	0.102	1,159	0.033	5,160
	20P/V-1500	1,950	0.093	700	0.033	3,439
	20P/V-1000	1,629	0.151	359	0.033	2,759
18" Span	20P/V-2100	3,706	0.064	2,914	0.050	8,866
	20P/V-1600	3,224	0.096	1,697	0.050	6,501
	20P/V-1100	2,536	0.187	691	0.050	5,509
	20P/V-2000	2,374	0.230	515	0.050	4,704
	20P/V-1500	1,300	0.209	311	0.050	3,136
	20P/V-1000	1,086	0.340	160	0.050	2,351
24" Span	20P/V-2100	2,780	0.113	1,639	0.067	8,181
	20P/V-1600	2,418	0.171	944	0.067	5,909
	20P/V-1100	1,902	0.326	389	0.067	4,979
	20P/V-2000	1,781	0.410	290	0.067	4,168
	20P/V-1500	975	0.371	175	0.067	2,778
	20P/V-1000	815	0.605	90	0.067	1,862
30" Span	20P/V-2100	2,224	0.177	1,049	0.083	7,405
	20P/V-1600	1,934	0.267	604	0.083	5,236
	20P/V-1100	1,522	0.509	249	0.083	4,375
	20P/V-2000	1,424	0.640	185	0.083	3,553
	20P/V-1500	780	0.580	112	0.083	2,369
	20P/V-1000	652	0.945	57	0.083	1,298
36" Span	20P/V-2100	1,853	0.254	730	0.100	6,451
	20P/V-1600	1,612	0.384	420	0.100	4,482
	20P/V-1100	1,268	0.734	173	0.100	3,698
	20P/V-2000	1,187	0.922	129	0.100	2,859
	20P/V-1500	650	0.836	78	0.100	1,906
	20P/V-1000	543	1.360	40	0.100	901
48" Span	20P/V-2100	1,390	0.452	410	0.133	4,534
	20P/V-1600	1,209	0.683	236	0.133	2,809
	20P/V-1100	951	1.304	97	0.133	2,254
	20P/V-2000	890	1.638	72	0.133	1,636
	20P/V-1500	488	1.486	44	0.133	1,091
	20P/V-1000	407	2.418	22	0.133	507
60" Span	20P/V-2100	1,112	0.707	262	0.167	2,902
	20P/V-1600	967	1.067	151	0.167	1,798
	20P/V-1100	761	2.038	62	0.167	1,442
	20P/V-2000	712	2.560	46	0.167	1,047
	20P/V-1500	390	2.321	28	0.167	698
	20P/V-1000	326	3.779	14	0.167	324
72" Span	20P/V-2100	927	1.018	182	0.200	2,015
	20P/V-1600	806	1.536	105	0.200	1,248
	20P/V-1100	634	2.935	43	0.200	1,001
	20P/V-2000	594	3.686	32	0.200	727
	20P/V-1500	325	3.343	19	0.200	485
	20P/V-1000	272	5.441	10	0.200	225

FEATURES
 SWAGE
 I-BEAM
 TROF
 EAGLE BASKET
 CHANNEL
 GLAS
 AICKINSTRUT
 DATA

Channel Fittings

Aickinstrut Channel Fittings are required to fabricate an Aickinstrut structure and are easily attached to Aickinstrut Channels with channel nuts and polyurethane fasteners. The fittings are offered in two types: fabricated (cut from flat stock) or molded. Fabricated fittings are made from either polyester or vinyl ester material. All molded fittings with the exception of the post bases are molded in polyurethane. Post bases are also offered in polypropylene.

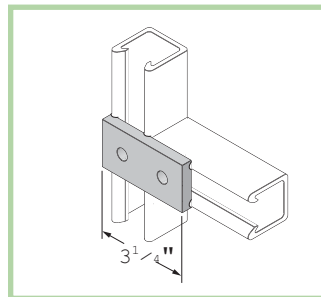
The 2500 Series Fittings are manufactured from 3/8" flat material. The 2800 Series Fittings are manufactured from 3/8" flat material and feature grooves which stabilize the fittings when mounted to the open side of the channel. **All channel fittings are provided with 1³/₃₂" holes which accommodate 3/8" hardware; however several of the new molded fittings come with 1/16" holes 50PU-2616, 50PU-2611, and 50PU-2613.** Larger diameter holes can be provided upon special request.

Legend

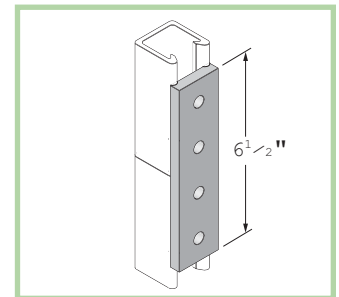
- R = Right Hand
- L = Left Hand
- P Series Fittings are Grey
- V Series Fittings are Beige
- 2500 Series - Flat
- 2800 Series - Grooved

Note: Illustrations depict grooved channel fittings.

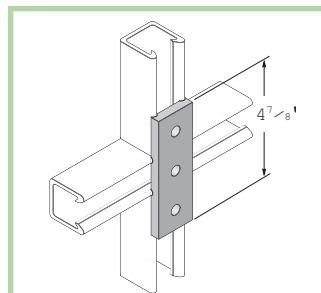
20P-2500, 20V-2500 (Flat)
20P-2800, 20V-2800 (Grooved)



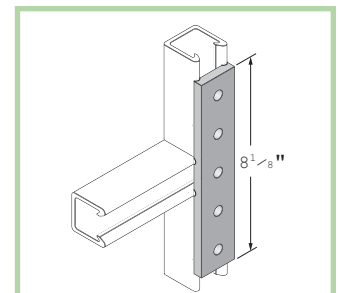
20P-2504, 20V-2504 (Flat)
20P-2804, 20V-2804 (Grooved)



20P-2502, 20V-2502 (Flat)
20P-2802, 20V-2802 (Grooved)



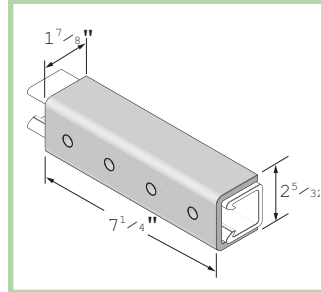
20P-2506, 20V-2506 (Flat)
20P-2806, 20V-2806 (Grooved)



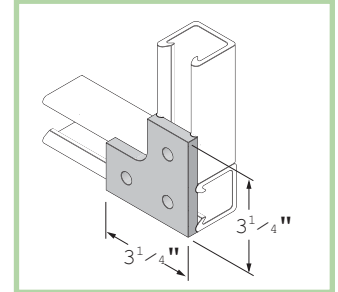
Channel Fittings

50PU-2616

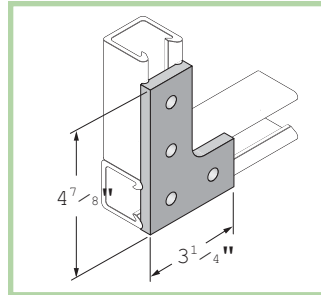
Note: $\frac{5}{16}$ " diameter holes



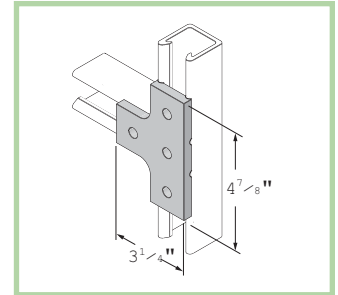
20P-2508, 20V-2508 (Flat) 20P-2808, 20V-2808 (Grooved)



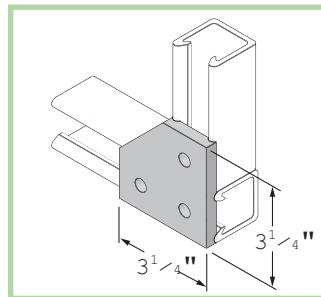
20P-2510, 20V-2510 (Flat) 20P-2810R, 20V-2810R (Grooved) 20P-2810L, 20V-2810L (Grooved)



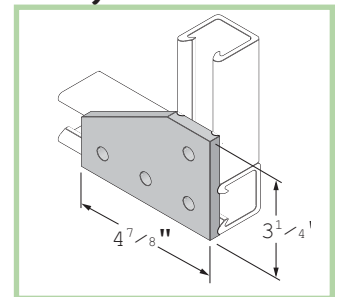
20P-2512, 20V-2512 (Flat) 20P-2812, 20V-2812 (Grooved)



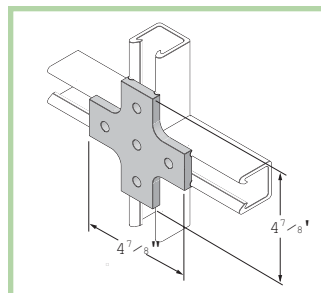
20P-2514, 20V-2514 (Flat) 20P-2814, 20V-2814 (Grooved)



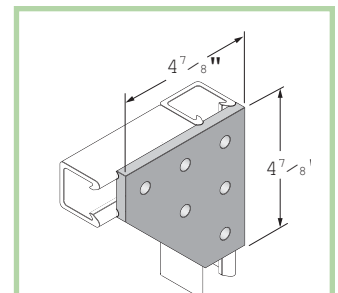
20P-2516, 20V-2516 (Flat) 20P-2816R, 20V-2816R (Grooved) 20P-2816L, 20V-2816L (Grooved)



20P-2518, 20V-2518 (Flat) 20P-2818, 20V-2818 (Grooved)

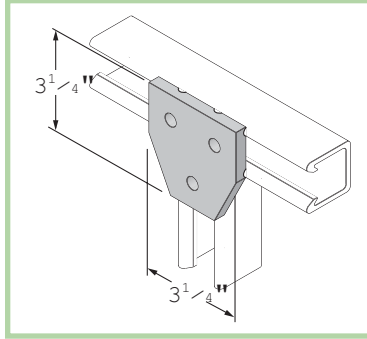


20P-2520, 20V-2520 (Flat) 20P-2820, 20V-2820 (Grooved)

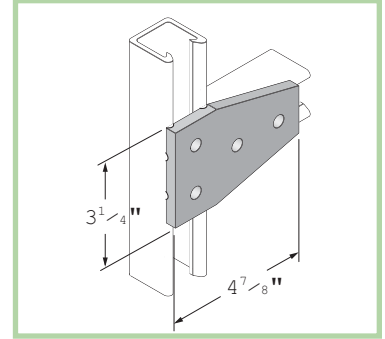


Channel Fittings

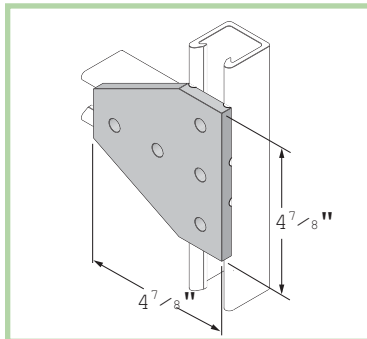
20P-2522, 20V-2522 (Flat)
20P-2822, 20V-2822 (Grooved)



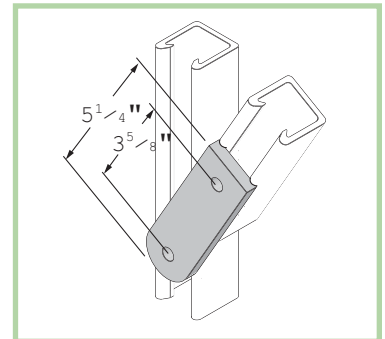
20P-2524, 20V-2524 (Flat)
20P-2824, 20V-2824 (Grooved)



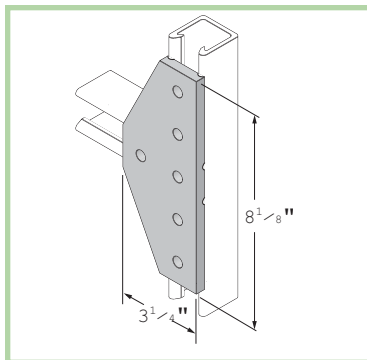
20P-2526, 20V-2526 (Flat)
20P-2826, 20V-2826 (Grooved)



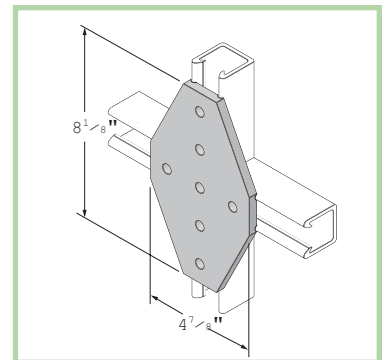
20P-2528, 20V-2528 (Flat)
20P-2828, 20V-2828 (Grooved)



20P-2530, 20V-2530 (Flat)
20P-2830, 20V-2830 (Grooved)

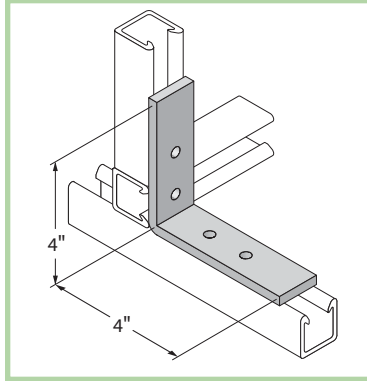


20P-2534, 20V-2534 (Flat)
20P-2834, 20V-2834 (Grooved)

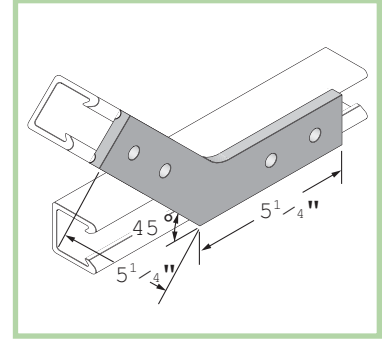


Channel Fittings

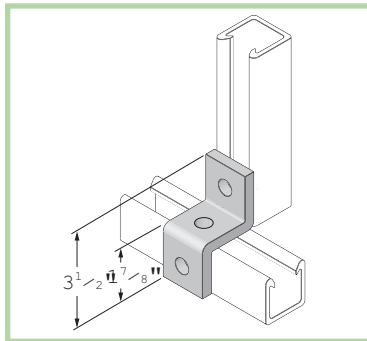
20P-2541, 20V-2541 (Flat)



20P-2540, 20V-2540 (Flat)
20P-2840, 20V-2840 (Grooved)

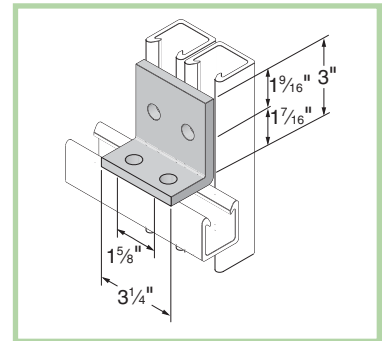


50PU-2611 (Flat)



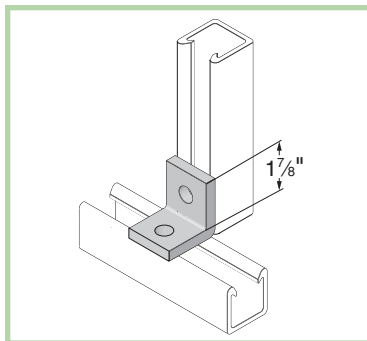
20P-2542, 20V-2542 (Flat)

Note: 9/16" diameter holes



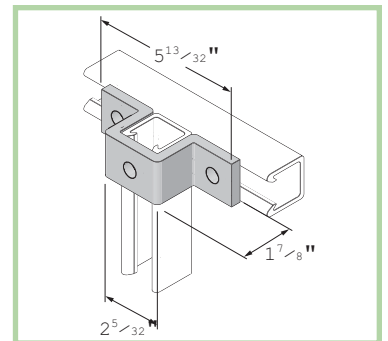
50PU-2611-SP

Note: 9/16" diameter holes



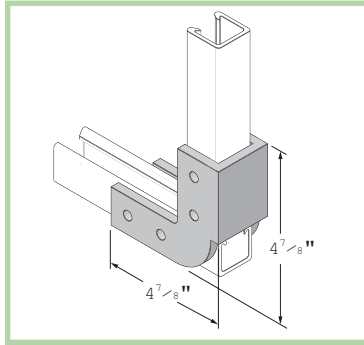
50PU-2613 (Flat)

Note: 9/16" diameter holes

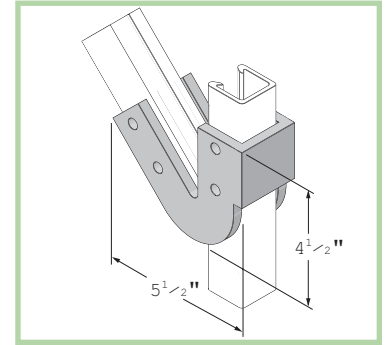


Channel Fittings

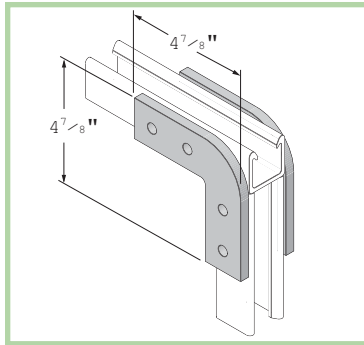
50PU-1508 (1 1/2")
50PU-2008 (1 5/8")



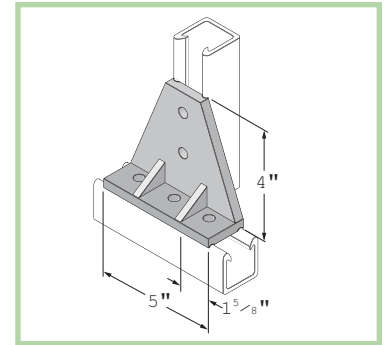
50PU-2045 (1 5/8")



50PU-2090 (1 5/8")

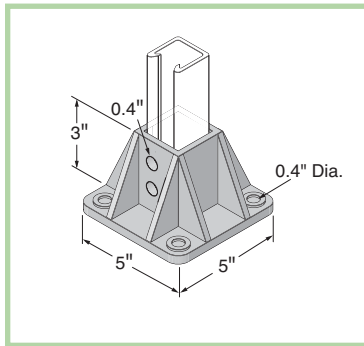


50PU-2538 (Flat)



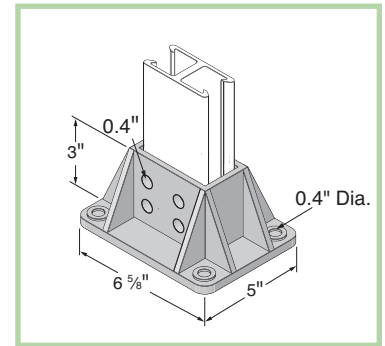
20PU-5853 (1 5/8"), 20PU-5854 (1 1/2"),
20PU-5855 (1 1/8"), 20PP-5853 (1 5/8"),
20PP-5854 (1 1/2"), 20PP-5855 (1 1/8")

Note: Single post base -
3/8" x 1-1/4" to use with
channel nut



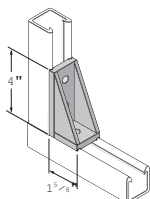
20PU-5903 (3 1/4"), 20PU-5904 (3"),
20PU-5905 (2 1/4"), 20PP-5903 (3 1/4"),
20PP-5904 (3"), 20PP-5905 (2 1/4")

Note: Double post base -
3/8" x 2-1/2" to go all
the way through



50PU-26361

1.) 50PU-2636 -
Grooved



50PU-2636A2

2.) 50PU-2636A -
Splines on long
side only



50PU-2636B3

3.) 50PU-2636B -
Splines on short
side only



50PU-29364

4.) 50PU-2936 -
Splines on both long
and short sides



Note: Grooved fittings are designed to aid in the alignment of connecting two pieces of Aickinstrut. The groove is engineered to wrap around the channel to secure the accurate connection without the use of angle tools. Grooved fittings are to be used with standard Aickinstrut channels only.

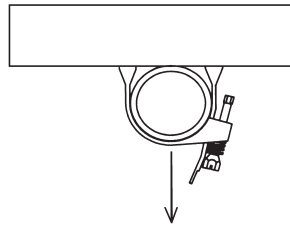
Aickinstrut

Aickinclamps Design Load Information

There are two types of piping system loadings, overhead (Type 1) and vertical (Type 2), as described below. All Aickinstrut pipe straps and clamps show the recommended loading for both types of loading.

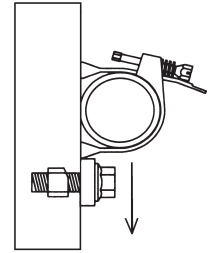
Type 1 Design Load

The design load shown represents pipes supported below the strut. The design loads shown are based on a minimum ultimate failure safety factor of 3:1.



Type 2 Design Load

The design loading shown can be achieved with the addition of a vertical stop lock assembly (Part #200-4219) installed directly beneath the pipe clamp. The adjacent illustration shows how the vertical stop lock assembly provides additional support for pipe and how it can be used to achieve full Type 2 design loads.

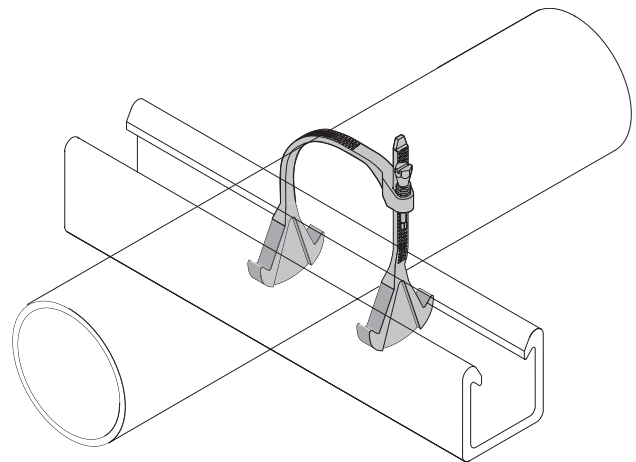


Design loads are based on a minimum clamp slip safety factor or 3:1. It is recommended that stop lock assemblies be used for all vertical pipe support applications.

Adjustable Pipe Clamps

Aickinstrut Adjustable Pipe Clamps are manufactured from glass-reinforced polyurethane and are adjustable to accommodate a wide range of outside diameters. They can be utilized with a variety of piping systems including PVC, fiberglass, copper, rigid steel conduit and PVC coated rigid steel conduit. Aickinclamps sized 6½" – 20" are to be used only in non-load bearing applications. These are applications where the weight of the pipe is being supported by Aickinstrut structural members (see figure on right). Aickinclamps can safely be used in temperatures up to 160°F. For operating temperatures of 160–230°F, it is recommended to use PVDF clamps. PVDF clamps are available as a special order. Contact the

factory for pricing and availability. Care should be taken not to exceed 3 ft.-lbs. of torque on the adjustable pipe straps.

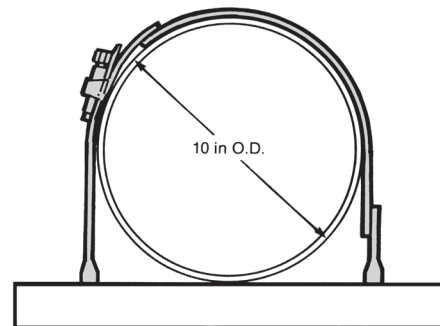


200-3100 to 200-3140

Adjustable Pipe Clamps

Part Number	O.D. Pipe Size	Design Load (lbs.)*		Torque (ft.-lbs.)
		Type 1	Type 2	
200-3100	½" – 1 ½"	135	65	10 in./lbs.
200-3110	1 ½" – 2 ¼"	135	65	3
200-3120	2 ¼" – 3 ¼"	145	70	3
200-3130	3" – 4"	215	70	3
200-3140	4" – 6 ½"	215	70	3

*Design loads shown represent a 3:1 safety factor.



200-3150 to 200-3210

Pipe Clamps

Rigid Pipe Clamps

Aickinstrut Rigid Pipe Clamps resemble the more traditional style of pipe clamps. These clamps are made from glass-reinforced polyurethane and are sized based on the pipe inside diameter or nominal size.

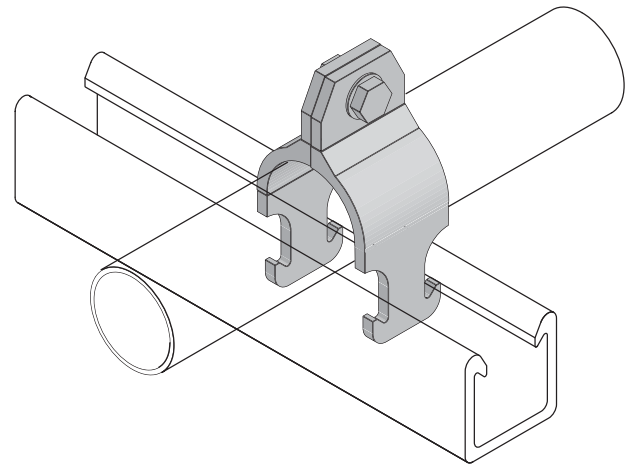
Polyurethane clamps are recommended for applications up to 160°F. For high temperature applications (up to 230°F), PVDF clamps are available as a special order. Contact the factory for pricing and availability.

Care should be taken not to exceed the recommended torque values of the rigid pipe clamps.

Rigid Pipe Clamps

Part Number	Nominal Size	PVC Sch. 80 and Rigid Metal	Design Loads (lbs.)*		FRP Bolt Size (in.)	FRP Bolt Torque (ft.-lbs.)
			Type 1	Type 2		
PCR-050	½"	0.84	225	90	⅜" x 1 ¼"	3
PCR-075	¾"	1.05	225	90	⅜" x 1 ¼"	3
PCR-100	1"	1.315	225	90	⅜" x 1 ¼"	3
PCR-125	1 ¼"	1.66	225	90	⅜" x 1 ¼"	3
PCR-150	1 ½"	1.9	225	90	⅜" x 1 ¼"	3
PCR-200	2"	2.375	225	90	⅜" x 1 ¼"	3
PCR-250	2 ½"	2.875	225	90	⅜" x 1 ¼"	3
PCR-300	3"	3.5	225	90	⅜" x 1 ¼"	3
PCR-400	4"	4.5	300	125	⅜" x 1 ¼"	3
PCR-600	6"	6.625	300	125	⅜" x 1 ¼"	3
PCR-800	8"	8.625	300	125	⅜" x 1 ¼"	3

*Design loads shown represent a 2:1 safety factor.



Note: Hardware included (1) 375PU-125 and (1) 375PU-000



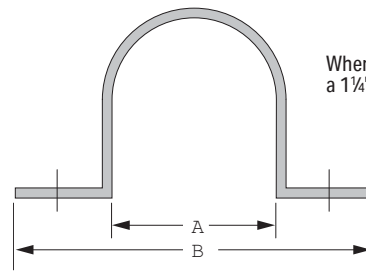
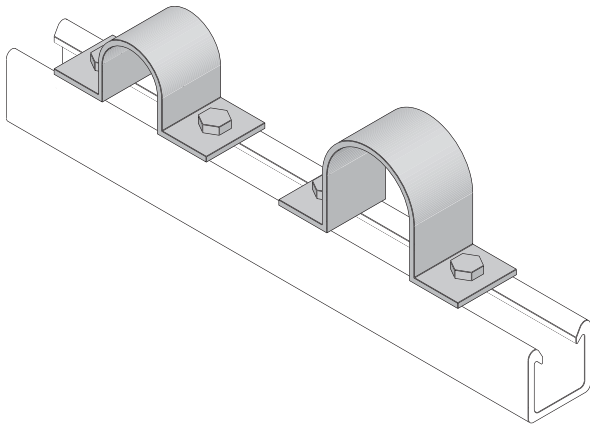
Pipe Clamps

Two Hole Pipe Straps

Aickinstrut Two Hole Pipe Straps are designed for use in securing pipe, conduit and ducts to Aickinstrut Channel. Two hole fiberglass straps can also be used independently from the channel for surface mounting. All sizes of the straps are suitable for load bearing applications.

The two hole pipe straps are manufactured from a fire-retardant, glass reinforced polyester

resin. For extreme chemical environments, the straps can be manufactured from vinyl ester resin. Larger diameter straps for special applications are also available. Contact the factory for pricing and availability of vinyl ester and large diameter straps. Two hole pipe straps should not be torqued above recommended values.



When bolting onto 1 5/8" or 1 1/2" channel a 1 1/4" long bolt is required.

Two Hole Pipe Straps

Part Number	Dimension		Bolt Size	Material Size	Design Load (lbs)*		Torque (ft.-lbs.)
	A	B			Type 1	Type 2	
PS050	0.84"	4.84"	1/2"	1/4" x 1 5/8"	135	50	4
PS075	1.05"	5.05"	1/2"	1/4" x 1 5/8"	135	50	4
PS100	1.315"	5.315"	1/2"	1/4" x 1 5/8"	135	50	4
PS150	1.9"	5.9"	1/2"	1/4" x 1 5/8"	135	50	4
PS200	2 3/8"	6.375"	1/2"	1/4" x 1 5/8"	135	50	4
PS250	2 7/8"	6.875"	1/2"	1/4" x 1 5/8"	135	50	4
PS300	3 1/2"	7.5"	1/2"	1/4" x 1 5/8"	135	50	4
PS350	4"	8"	1/2"	1/4" x 1 5/8"	135	50	4
PS400	4 1/2"	8.5"	1/2"	1/4" x 1 5/8"	175	60	4
PS500	5 9/16"	9.563"	1/2"	1/4" x 1 5/8"	175	60	4
PS600	6 5/8"	10.625"	1/2"	1/4" x 1 5/8"	175	60	4
PS800	8 5/8"	12.625"	1/2"	1/4" x 1 5/8"	225	125	4
PS1000	10 3/4"	15.75"	5/8"	1/4" x 1 5/8"	225	125	10
PS1200	12 3/4"	16.25"	5/8"	1/4" x 1 5/8"	225	125	10
PS1400	14"	18"	5/8"	3/8" x 1 5/8"	250	150	10
PS1600	16"	20"	5/8"	3/8" x 1 5/8"	250	150	10
PS1800	18"	23"	5/8"	3/8" x 1 5/8"	250	150	10

*Design loads shown represent a 3:1 safety factor.
Note: Bolts and channel nuts are sold separately.

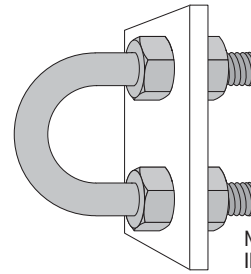
Pipe Clamps

Nonmetallic U-bolts

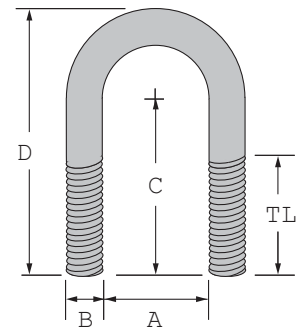
Aickinstrut Nonmetallic U-Bolts provide a corrosion resistant alternative to traditional metallic U-Bolts. Made from glass-reinforced polyurethane, these bolts will outlast stainless steel in most corrosive applications. Nonmetallic U-Bolts have oversized diameters which allow them to hold steel conduit and plastic pipe.

Each U-Bolt comes with two polyurethane hex nuts. Additional nuts and washers can be purchased separately.

The U-Bolts can also be installed to allow for thermal expansion and contraction of plastic pipe as shown here.



Note: Plate not included.
Illustration purpose only



U-Bolts

Part Number	Size	"A" Dim.	"B" Dim.	"C" Dim.	"D" Dim.	"TL" Dim.	Load (lbs.)*	Torque (ft.-lbs.)*
UB-050	½"	0.937"	0.375"	1.568"	2.412"	1.25"	135	40
UB-075	¾"	1.125"	0.375"	1.662"	2.600"	1.25"	135	40
UB-100	1"	1.375"	0.375"	1.787"	2.850"	1.25"	135	40
UB-125	1 ¼"	1.687"	0.375"	1.943"	3.162"	1.25"	135	40
UB-150	1 ½"	2.000"	0.375"	2.100"	3.475"	1.25"	135	40
UB-200	2"	2.437"	0.500"	2.468"	4.187"	1.50"	135	80
UB-250	2 ½"	2.937"	0.500"	2.718"	4.687"	1.50"	135	80
UB-300	3"	3.562"	0.500"	3.031"	5.312"	1.50"	135	80
UB-350	3 ½"	4.062"	0.500"	3.281"	5.812"	1.50"	135	80
UB-400	4"	4.562"	0.500"	3.531"	6.312"	1.50"	135	80
UB-600	6"	6.750"	0.625"	5.750"	9.875"	3.25"	135	120

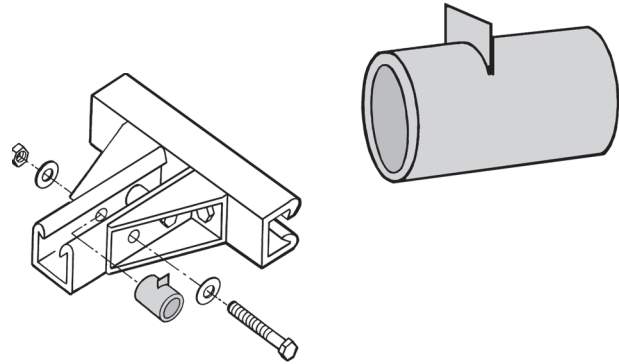
*Design loads shown represent a 3:1 safety factor.
Note: Bolts and channel nuts are sold separately.



Pipe Clamps

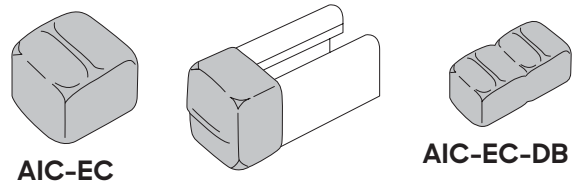
Channel Spacers 50PU-500SP

Channel spacers are designed to prevent wall compression under heavy loading conditions. Such loading occurs during the torquing of hardware for channel fittings. The spacers are molded from polyurethane and will accommodate $\frac{3}{8}$ " and $\frac{1}{2}$ " bolts. The spacers are designed to be used only with $1\frac{5}{8}$ " and $1\frac{1}{2}$ " channels.



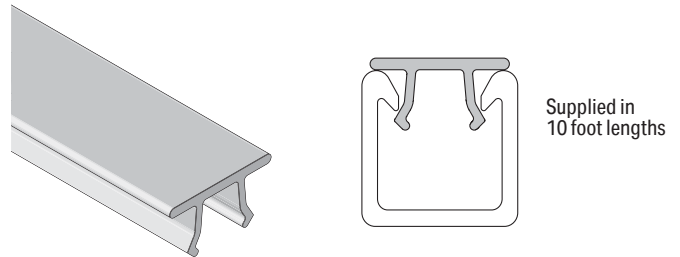
Channel End Cap AIC-EC

The Aickin-End Cap is made from red PVC and designed for $1\frac{5}{8}$ " channel. End caps are desired when the ends of the channel need to be enclosed. The Aickin-End Cap easily installs by pressing it onto the end of the channel opening.



Channel Capping Strip 20E-5000

Channel Capping Strip is made from PVC and installs simply by pressing it onto the channel opening. It is designed to be used when a cover is desired for the channel opening (such as concrete embedment channel).



Fasteners

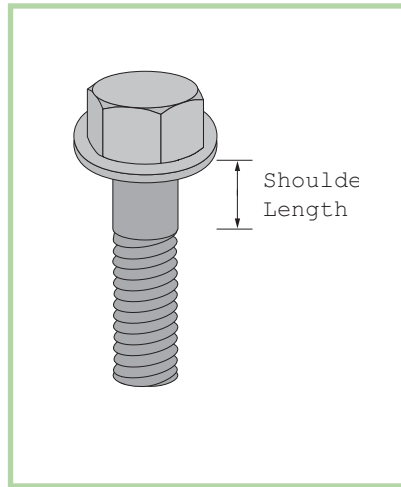
Fiberfast Bolts

Fiberfast bolts are provided in two styles and five diameters ($\frac{1}{4}$ ", $\frac{3}{8}$ ", $\frac{1}{2}$ ", $\frac{5}{8}$ " and $\frac{3}{4}$ ") and range in length from $1\frac{1}{4}$ " to $3\frac{1}{2}$ ". The flanged style incorporates a molded washer collar which eliminates the need for a washer.

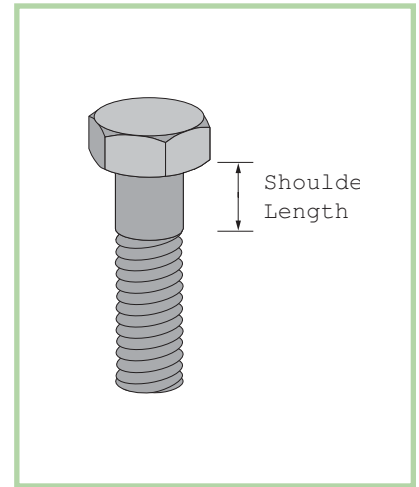
The flanged style is provided for $\frac{1}{4}$ " and $\frac{1}{2}$ " diameter bolts. Flanged bolts are available in $\frac{3}{8}$ " diameter as a special order item. The hex head style is provided for all $\frac{3}{8}$ ", $\frac{5}{8}$ " and $\frac{3}{4}$ " diameter bolts. All Fiberfast bolts are not

fully threaded; therefore, shoulder length (nonthreaded portion) dimensions have been provided. Fiberfast bolts are ideal for mechanical connections that require a high degree of corrosion resistance. The $\frac{3}{8}$ " diameter fasteners are recommended for all channel fitting mechanical connections. All Fiberfast bolts are manufactured from glass-reinforced polyurethane and are packaged in bags containing 25 pieces.

Hex Flange Bolts



Hex Bolts



Hex Flange Bolts

Part Number	Size	Thread Shear (lbs.)*	Shank Shear (lbs.)*	Shoulder Length	Torque (ft.-lbs.)
250PU-075	$\frac{1}{4}$ " x $\frac{3}{4}$ "	110	210	Full Thread	10 In./lbs.
250PU-100	$\frac{1}{4}$ " x 1"	110	210	Full Thread	10 In./lbs.
250PU-150	$\frac{1}{4}$ " x $1\frac{1}{2}$ "	110	210	$\frac{1}{2}$ "	10 In./lbs.
312PU-100	$\frac{5}{16}$ " x 1"	160	300	Full Thread	20 In./lbs.
312PU-125	$\frac{5}{16}$ " x $1\frac{1}{4}$ "	160	300	Full Thread	20 In./lbs.
312PU-200	$\frac{5}{16}$ " x 2"	160	300	$\frac{1}{2}$ "	20 In./lbs.
500PU-125	$\frac{1}{2}$ " x $1\frac{1}{4}$ "	450	870	Full Thread	8
500PU-150	$\frac{1}{2}$ " x $1\frac{1}{2}$ "	450	870	Full Thread	8
500PU-200	$\frac{1}{2}$ " x 2"	450	870	$\frac{3}{4}$ "	8
500PU-250	$\frac{1}{2}$ " x $2\frac{1}{2}$ "	450	870	$\frac{3}{4}$ "	8
500PU-300	$\frac{1}{2}$ " x 3"	450	870	1"	8
500PU-350	$\frac{1}{2}$ " x $3\frac{1}{2}$ "	450	870	$2\frac{3}{16}$ "	8

*Thread shear values shown represent a 3:1 safety factor.

Hex Bolts

Part Number	Size	Thread Shear (lbs.)*	Shank Shear (lbs.)*	Shoulder Length	Torque (ft.-lbs.)
375PU-125	$\frac{3}{8}$ " x $1\frac{1}{4}$ "	250	470	Full Thread	3
375PU-150	$\frac{3}{8}$ " x $1\frac{1}{2}$ "	250	470	$\frac{1}{4}$ "	3
375PU-200	$\frac{3}{8}$ " x 2"	250	470	$\frac{1}{2}$ "	3
375PU-250	$\frac{3}{8}$ " x $2\frac{1}{2}$ "	250	470	$\frac{3}{4}$ "	3
375PU-300	$\frac{3}{8}$ " x 3"	250	470	1"	3
625PU-125	$\frac{5}{8}$ " x $1\frac{1}{4}$ "	700	1,360	$\frac{1}{4}$ "	12
625PU-150	$\frac{5}{8}$ " x $1\frac{1}{2}$ "	700	1,360	$\frac{1}{4}$ "	12
625PU-200	$\frac{5}{8}$ " x 2"	700	1,360	$\frac{1}{4}$ "	12
625PU-250	$\frac{5}{8}$ " x $2\frac{1}{2}$ "	700	1,360	$\frac{1}{4}$ "	12
625PU-300	$\frac{5}{8}$ " x 3"	700	1,360	$\frac{1}{4}$ "	12
625PU-350	$\frac{5}{8}$ " x $3\frac{1}{2}$ "	700	1,360	$1\frac{1}{4}$ "	12

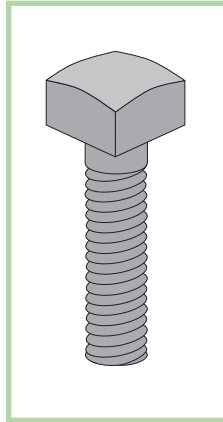
*Thread shear values shown represent a 3:1 safety factor.



Fasteners

Vinyl Ester Square Head Bolts

Vinyl ester square head bolts are used for concrete mounting and general purpose fastening applications. The square head bolts are constructed from vinyl ester all-thread rod and vinyl ester square nuts. The units are bonded together with a durable two part urethane adhesive. The square head bolts are offered in 3/8" diameter but can be supplied in other diameters as a special order. Contact the factory for pricing and availability of special diameter square head bolts.



Vinyl Ester Square Head Bolts

Part Number	Size (in.)	Thread Shear (lbs.)*	Torque (ft.-lbs.)
375V-100	3/8 x 1	250	10
375V-125	3/8 x 1 1/4	250	10
375V-150	3/8 x 1 1/2	250	10
375V-175	3/8 x 1 3/4	250	10
375V-200	3/8 x 2	250	10
375V-250	3/8 x 2 1/2	250	10
375V-300	3/8 x 3	250	10
375V-350	3/8 x 3 1/2	250	10
375V-400	3/8 x 4	250	10

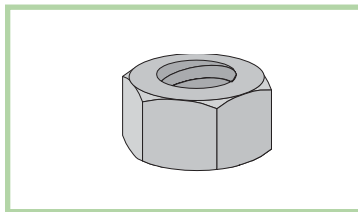
*Thread shear values shown represent a 3:1 safety factor.

Fiberfast Hex Nuts

Aickinstrut hex nuts are available in two styles: hex and hex flange nuts. The Aickinstrut hex nut is similar in design to the conventional hex nut and is preferred for channel fitting connections. The Aickinstrut hex flange nut is preferred for applications that require additional thread engagement (such as with all-thread

rod) or maximum thread shear strength. All nuts are manufactured from glass-reinforced polyurethane and are packaged in bags containing 25 pieces. All hex and hex flange nuts are available in PVDF and Polypropylene and metric sizes as a special order. Contact the factory for pricing and availability.

Hex Nuts

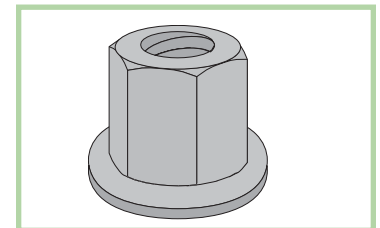


Hex Nuts

Part Number	Size	Thread Shear (lbs.)*	Height	Torque (ft.-lbs.)
250PU-000	1/4"-20"	150	0.218"	10 in./lbs.
312PU-000	5/16"-18"	160	0.273"	20 in./lbs.
375PU-000	3/8"-16"	460	0.328"	3
500PU-000	1/2"-13"	800	0.437"	8
625PU-000	5/8"-11"	1,000	0.546"	12
750PU-000	3"-10"	1,000	0.640"	15
1000PU-000	1"-8"	1,100	0.859"	17

*Thread shear values shown represent a 3:1 safety factor.

Hex Flange Nuts



Hex Flange Nuts

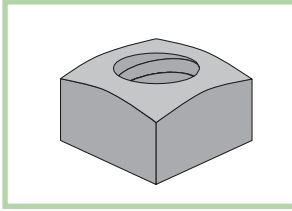
Part Number	Size	Thread Shear (lbs.)*	Height	Torque (ft.-lbs.)
375PU-FN-000	3/8"-16"	500	0.750"	3
500PU-FN-000	1/2"-13"	1,200	0.855"	8
625PU-FN-000	5/8"-11"	2,200	1.220"	12
750PU-FN-000	3/4"-10"	2,900	1.590"	15
1000PU-FN-000	1"-8"	2900	1.750"	17

*Thread shear values shown represent a 3:1 safety factor.

Fasteners

Vinyl Ester Square Nuts

Square nuts are manufactured from pultruded vinyl ester square stock. They are recommended for applications that require high thread shear values. Square nuts are packaged in bags containing 25 pieces.



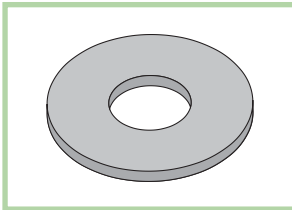
Vinyl Ester Square Nuts

Part Number	Size	Thread Shear (lbs.)*	Height	Torque (ft.-lbs.)
375V-000	3/8"-16"	1,300	0.437"	10
500V-000	1/2"-13"	1,700	0.562"	10
625V-000	5/8"-11"	1,700	0.687"	10
750V-000	3/4"-10"	1,700	0.812"	10
1000V-000	1"-8"	1,700	0.937"	10

*Thread shear values shown represent a 3:1 safety factor.

Flat Washers

Flat Washers are made from PVC and are available for 1/4" diameter through 1". PVC washers are recommended for connections that utilize hex nuts and bolts. PVC washers are packaged in bags containing 25 pieces.

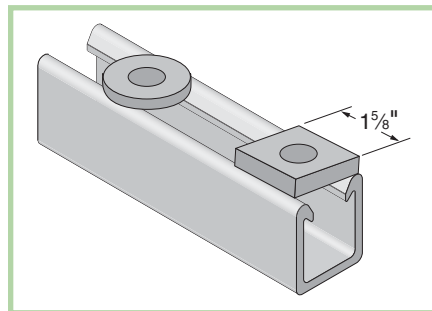


Flat Washers

Part Number	Size	Outside Diameter
250E-999	1/4"	0.49"
312E-999	5/16"	0.75"
375E-999	3/8"	1.00"
500E-999	1/2"	1.25"
625E-999	5/8"	1.50"
750E-999	3/4"	1.50"
1000E-999	1"	2.25"

All-Thread Washers

Aickinstrut All-Thread Washers are flat fiberglass washers for use with FRP all-thread rods. All-Thread rod washers are 1/4" thick with a 1-7/8" diameter and are available in polyester or vinyl ester resin.



All-Thread Washers

Part Number Round Washer*	Part Number Square Washing	All-Thread Rod Size
WR375	WR375SQ	3/8"
WR500	WR500SQ	1/2"
WR625	WR625SQ	5/8"
WR750	WR750SQ	3/4"

* Add the suffix "V" to the part number to specify vinyl ester
Example "WR500V"

* Add the suffix "-SQ" to the part number to specify square washer
Example "WR500-SQ"

To order vinyl ester, add the suffix "V" to the part number.



Fasteners

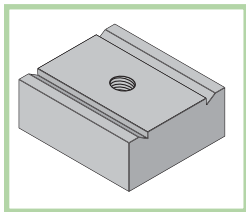
Channel Nuts

Channel nuts are provided in two types: Standard Duty and Heavy Duty. Standard Duty channel nuts are designed for light duty applications that do not require high thread shear values. Standard duty channel nuts can also be used with all sizes of Aickinstrut Channel. Heavy duty channel nuts are designed to be used where high thread shear

values or spring nuts are required. Heavy duty channel nuts cannot be used with Series 1000 Channel (light duty). All channel nuts are manufactured from glass-reinforced polyurethane and are packaged in bags containing 25 pieces. Channel nuts are also available in PVDF as a special order. Contact the factory for pricing and availability.

Heavy Duty Channel Nuts

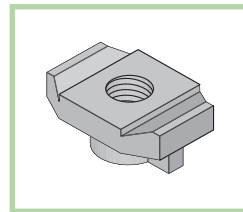
Standard Duty Channel Nuts



Heavy Duty Channel Nuts

Part Number	Size	Thread Shear (lbs.)*	Torque (ft.-lbs.)
375PU-CNHD	3/8"-16"	1,400	8
500PU-CNHD	1/2"-13"	1,400	8
625PU-CNHD	5/8"-11"	1,400	10
750PU-CNHD	3/4"-10"	1,400	10
10PU-CNMHD	10 mm	1,400	8
12PU-CNMHD	12 mm	1,400	8
16PU-CNMHD	16 mm	1,400	10
20PU-CNMHD	20 mm	1,400	10

*Thread shear values shown represent a 3:1 safety factor.



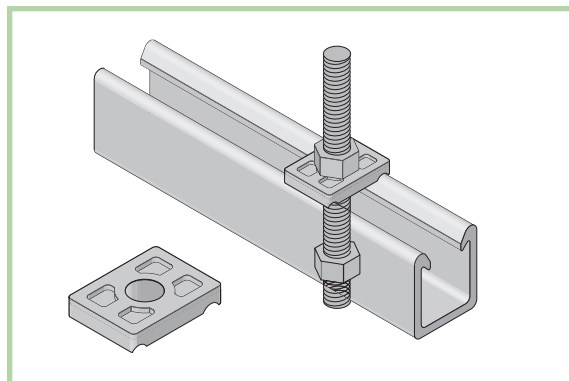
Standard Duty Channel Nuts

Part Number	Size	Thread Shear (lbs.)*	Torque (ft.-lbs.)
250PU-CN	1/4"-20"	460	2
312PU-CN	5/16"-18"	460	2
375PU-CN	3/8"-16"	460	3
500PU-CN	1/2"-13"	460	3
10PU-CN	10 mm	460	3
12PU-CN	12 mm	460	3
10PU-CNS	#10 Screw	460	N/A

*Thread shear values shown represent a 3:1 safety factor.

Saddle Clips

Aickinstrut Saddle Clips make fastening through Aickinstrut channel much easier. The clips mate with the exterior of the channel flanges and are secured with threaded rods and nuts. The saddle clips are manufactured from glass reinforced polyurethane and are supplied in bags of 25 pieces.



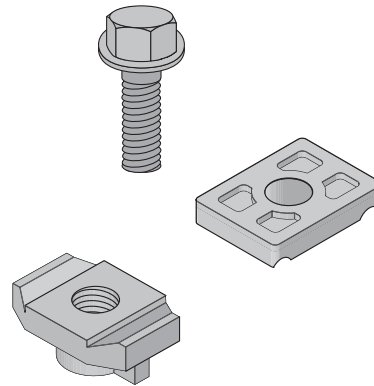
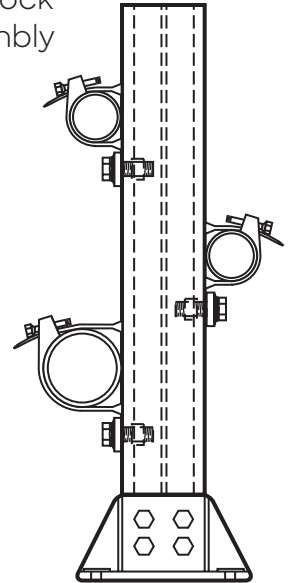
Part Number	Size
200-4226	3/8"
200-4217	1/2"
200-4341	5/8"
200-4342	3/4"

Fasteners

Stop-Lock Assemblies

Aickinstrut Stop-Lock Assemblies reduce the chance of pipe slippage when running supports vertically. Stop-Locks are recommended for applications that are subject to vibration, have regular contact with fluids or are vertically mounted (Type 2). The Stop-Locks fit all three sizes of channel. Stop-Locks are offered with a 3/8", 1/2" and 5/8" bolt size. The 5/8" Stop-Lock Assembly is supplied with a heavy duty channel nut (the 5/8" Stop-Lock Assembly will not work with the Series 1000 Channel).

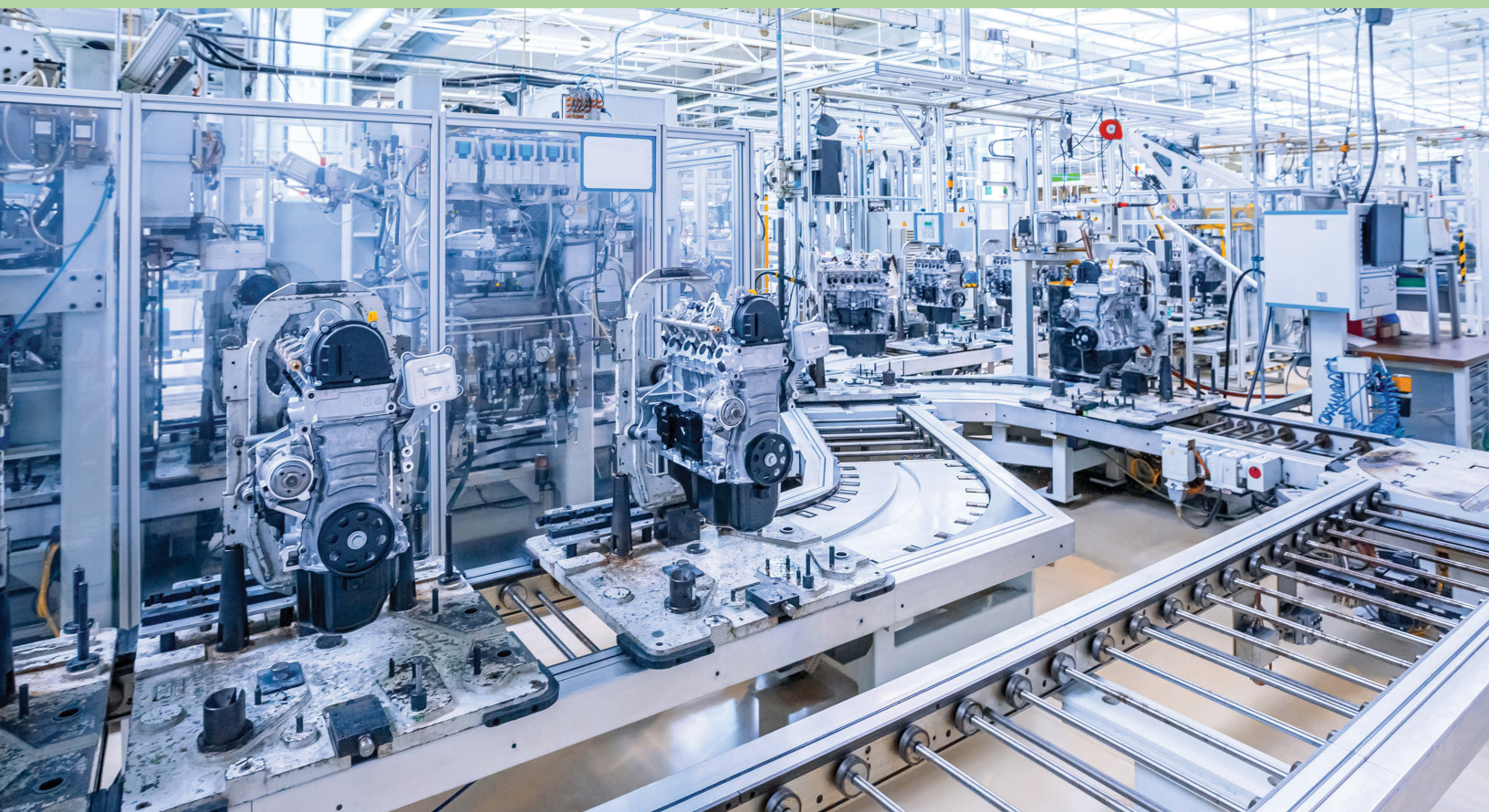
The Stop-Lock Assemblies' components are manufactured from glass-reinforced polyurethane.



Stop-Lock Assemblies

Part Number	Size	Force	
		Resistance (lbs.)*	Torque (ft.-lbs.)
200-4227	3/8"	200	7
200-4219	1/2"	220	12
200-4343	5/8"	250	15

*Force resistance values shown represent a 2:1 safety factor based on current testing

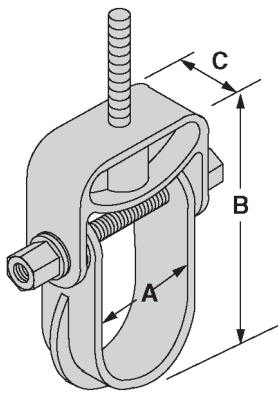


Pipe Hangers

Clevis Hangers

Clevis hangers are available in two styles: molded and hand lay-up. The molded clevis hangers are manufactured from glass-reinforced polyurethane and are available for sizes ½" through 6". The hand lay-up clevis hangers are manufactured from glass-reinforced polyester and are available for sizes 1" through 24".

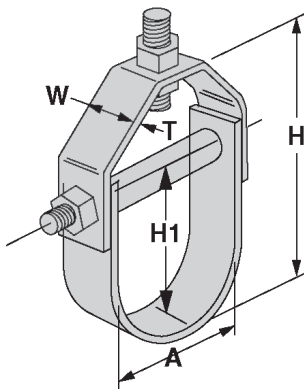
Molded Clevis Hangers



Part Number	Nominal Diameter	Max. Pipe O.D.	"A" Dim.	"B" Dim.	"C" Dim.	Hanger Rod	Load (lbs.)*
CVHPU-100	½" - 1"	1"	1.5"	4.25"	1.25"	½"	670
CVHPU-150	1 ¼" - 1 ½"	1 ½"	2.0"	5.14"	1.25"	½"	670
CVHPU-200	1 ½" - 2"	2"	2.5"	6.52"	1.25"	½"	730
CVHPU-400	2 ½" - 4"	4"	5.1"	10.00"	1.50"	½"	1,150
CVHPU-600	4 ½" - 6"	6"	6.8"	12.33"	1.50"	½"	1,170

*Design load values shown represent a 3:1 safety factor.

Hand Lay-Up Clevis Hangers



Part Number	Size Range		Dimensions			Hanger Rod	Trans Rod	Spreader Rod O.D.	Loads (lbs.)*
	A	T	H	H1	W				
100-1500	1" - 1 ½"	⅛"	2 ¾"	1 ⅞"	1 ½"	½"	⅜"	½"	60
100-1501	1 ½" - 2"	⅛"	3 ½"	2 ⅜"	1 ½"	½"	⅜"	½"	60
100-1502	2" - 2 ⅝"	⅛"	4 ¾"	3"	2"	½"	⅜"	½"	90
100-1503	2 ½" - 3 ¼"	⅛"	5 ½"	3 ⅝"	2"	½"	⅜"	½"	120
100-1504	3" - 3 ⅞"	⅛"	7"	4 ¼"	2"	⅝"	⅜"	½"	160
100-1505	4" - 5 ⅛"	⅜"	8 ½"	5 ⅝"	2"	⅝"	⅜"	½"	250
100-1506	6" - 7 ⅞"	⅜"	10 ⅞"	7 ½"	3"	⅝"	⅜"	½"	300
100-1507	8" - 9 ¼"	¼"	14"	9 ¾"	3"	⅝"	⅜"	½"	350
100-1508	10" - 11 ⅜"	¼"	18"	12"	4"	⅝"	½"	¾"	450
100-1509	12" - 13 ½"	¼"	21 ½"	14 ⅞"	5"	⅝"	½"	¾"	600
100-1510	14" - 15 ¾"	¼"	24 ½"	16 ½"	5"	¾"	½"	¾"	700
100-1511	16" - 18"	⅜"	27 ⅜"	19 ½"	6"	¾"	¾"	1"	750
100-1512	19" - 21"	⅜"	34 ½"	22 ½"	6"	¾"	¾"	1"	800
100-1513	21" - 22"	½"	35 ½"	24"	6"	¾"	¾"	1"	850
100-1514	22" - 24"	½"	41"	28"	6"	¾"	¾"	1"	900

*Design load values shown represent a 3:1 safety factor.

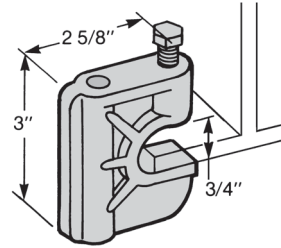
Pipe Hanging Accessories

Beam Clamps

Aickinstrut beam clamps are available in two styles: molded and fabricated. The molded beam clamps are manufactured from glass-reinforced polyurethane and can accommodate 3/8", 1/2" and 5/8" hanger rod sizes. The molded beam clamps utilize the traditional "C" clamp style design. The fabricated beam clamps are manufactured from vinyl ester flat stock and utilize polyurethane bolts and channel nuts for clamping. Fabricated beam clamps are available for attaching to 1/4", 3/8" and 1/2" thick beam flanges. Each fabricated beam clamp assembly includes four (4) 1/2" standard duty channel nuts, four (4) 1/2" Polyurethane bolts and two (2) attachment clips.

All Aickinstrut beam clamps allow easy attachment of threaded rod to I-Beams or other structural assemblies.

Molded Beam Clamps

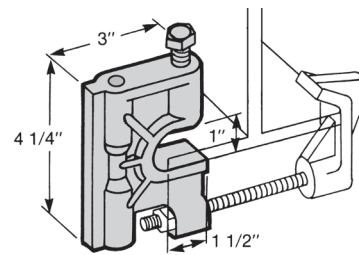


Part Number	Size	Thread Shear (lbs.)*	Torque (ft.-lbs.)
375PU-BC	3/8"	400	10
500PU-BC	1/2"	400	10

*Design load values shown represent a 3:1 safety factor.

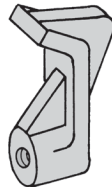
Cope-GLAS Beam Clamps

Note: Beam clamp clip must be purchased separately. Illustration purpose only

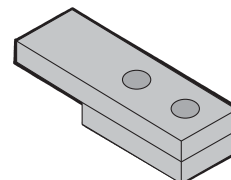
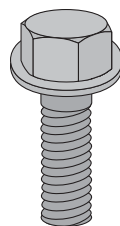
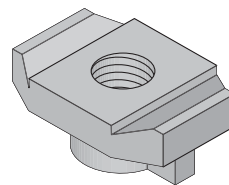
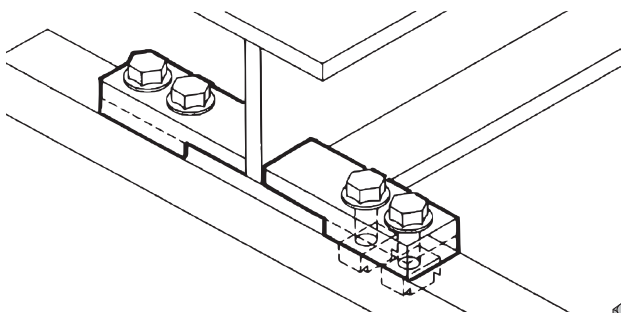


Part Number	Size	Thread Shear (lbs.)*	Torque (ft.-lbs.)
RGBC1	3/8"	500	10
RGBC2	1/2"	500	10
RGBC3	5/8"	500	10

Beam Clip - 375PU-BCCLP (3/8")



Fabricated Beam Clamps



Part Number	Size	Thread Shear (lbs.)*	Torque (ft.-lbs.)
20V-2BC-25	1/4"	600	10
20V-2BC-37	3/8"	600	10
20V-2BC-50	1/2"	600	10

*Design load values shown represent a 3:1 safety factor. Bolts and channel nuts are 1/2" diameter.

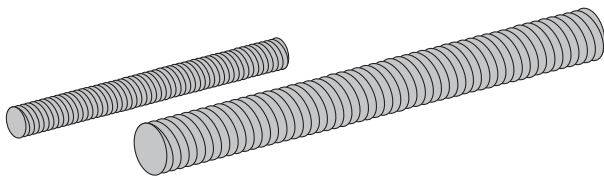


Pipe Supports

Threaded Rod

Pultruded threaded rods are an excellent choice for hanging and fastening Aickinstrut Channel. These rods can also be used with either the Aickinstrut vinyl ester square nuts, polyurethane hex nuts, hex flange nuts and Aickinstrut channel nuts. All FRP threaded rod is manufactured from pultruded vinyl ester resin and is gray in color.

The standard rod lengths are 4' and 8'.



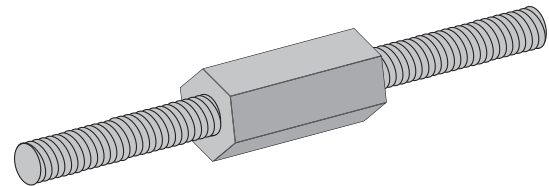
Part Number	Size	Weight (lbs.)	Thread Shear (lbs.)*	Torque (ft.-lbs.)
200-3827	3/8"-16"	0.07	415	5
200-3828	1/2"-13"	0.12	570	10
200-3829	5/8"-11"	0.18	1,260	40
200-3830	3/4"-10"	0.28	1,700	50
200-3831	1"-8"	0.50	3,000	60

* Thread shear values shown represent a 3:1 safety factor.

* To order eight foot lengths, add suffix "-96" to part number (EX: 200-3827-96)

A-Konnector Rod Couplers

A-Konnectors provide an excellent means for extending Aickinstrut FRP all-thread rods beyond their standard lengths. A-Konnectors are manufactured from glass-reinforced polyurethane and are colored gray. A-Konnectors are packaged in bags containing 25 pieces.

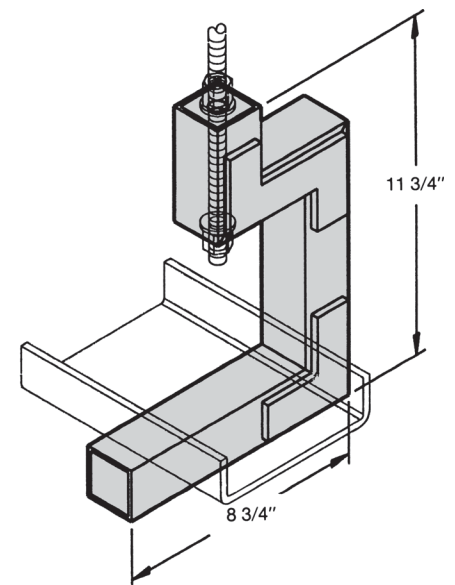


Part Number	Size	Length	Thread Shear (lbs.)*
200-3840	3/8"-16"	2 1/4"	800
200-3841	1/2"-13"	2 1/4"	870
200-3842	5/8"-11"	2 1/4"	1,500
200-3843	3/4"-10"	2 1/4"	1,500

* Thread shear values shown represent a 3:1 safety factor.

Channel Hangers **AIC-CH-P (Polyester)** **AIC-CH-V (Vinyl Ester)**

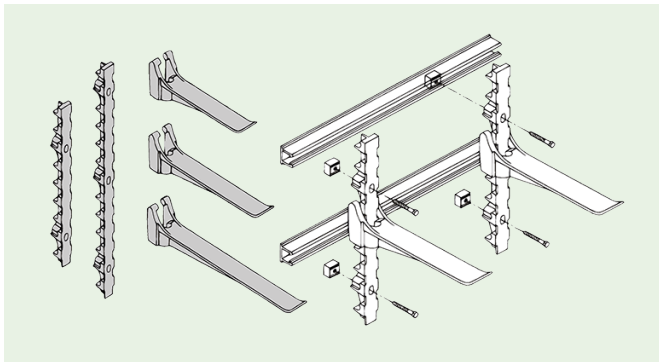
The Aickin-Channel Hanger is designed to support fiberglass structural "C" channel that is being used as a raceway system for cables, tubing or small diameter piping. The Aickin-Channel Hanger is available in either polyester or vinyl ester resin and is simply supported from a 1/2" FRP all-thread rod and beam clamp (not provided). The Channel Hanger will accommodate "C" channel width sizes 2" through 8".



Pipe Supports

Power-Rack Stanchions

The Power-Rack Stanchion is the new alternative to traditional iron cable stanchions used for utility and industrial cable supports. Made entirely from glass-reinforced nylon, these stanchions out-perform metallic supports against corrosion. The extended life-span of the Power-Rack Stanchions makes them the logical choice over metallic cable supports. The Power-Rack Stanchion is available in two different lengths and four different arm lengths. The unique interlocking design allows the arm to "lock" into nine different levels on the 14 ¼" stanchions and 14 levels on the 17 ½" stanchion. Glass-reinforced polyurethane stanchions are available as a special order. Contact the factory for pricing and availability.



Dimensions – The stanchion back is designed with 9/16" wide x 1 1/16" long holes to accept fasteners for mounting. There are two mounting holes in the 21 3/8" long stanchion and three mounting holes in the 33 5/16" long stanchion. Thickness at the slotted mounting holes is 1 7/8". The mounting holes are spaced on 12" centers and require 1/2" diameter fasteners.

Installation – The Power-Rack Stanchions can be anchored into existing concrete structures using any good quality industrial anchoring system. For new concrete structures, the Power-Rack Stanchions can be mounted to Aickinstrut concrete embedment channel and attached with 1/2" channel nuts and 1/2"x 3" Fiberfast Bolts.

Fire Retardance – Power-Rack materials meet or exceed the requirements of UL94 HB.

Loading – The recommended allowable loads on Power-Rack Stanchions vary depending upon the position of the arm. Following the guidelines listed below will ensure a safe, reliable installation.

- Total load on any one arm should not exceed 800 lbs.
- The sum of the loads on any arm multiplied by their distances to the wall stanchion should not exceed 1200 in-lb

Example – A cable weighing 200 lbs. is positioned on an arm at a distance of 5" from the wall stanchion.

If the total load is less than 800 lbs and the sum of the load multiplied by their distances to the wall stanchion does not exceed 1200 in-lb, then the system is adequate. In this case,

Total load (200 < 800 lbs) = OK

Tot. moment (200x5 in. = 1000 < 1200 in-lb) = OK

Part No.	Description	Weight (lbs.)	Load (lbs.)*
20N-ARM08	8" Arm	1	800
20N-ARM14	14 ¼" Arm	1.16	800
20N-ARM17	17 ½" Arm	1.45	800
20N-ARM23	23 7/8" Arm	1.86	800
20N-STA21	21 3/8" Stanchion	1.49	N/A
20N-STA33	33 5/16" Stanchion	2.31	N/A

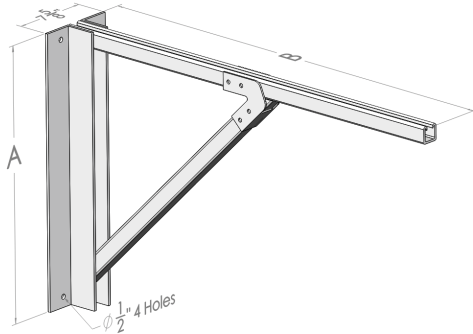
* Thread shear values shown represent a 3:1 safety factor.

* To order eight foot lengths, add suffix "-96" to part number (EX: 200-3827-96)

Pipe Supports

Wall Brackets

Constructed of Aickinstrut fiberglass components, Wall Support Brackets are an alternative tray hanging system. The Aickinstrut product line offers a complete line of fasteners that can be used with the wall brackets in many different tray clamping schemes. Installation guidelines for wall brackets are located in the Installation Procedures Section of this catalog. To specify vinyl ester, add suffix "V" to part number.



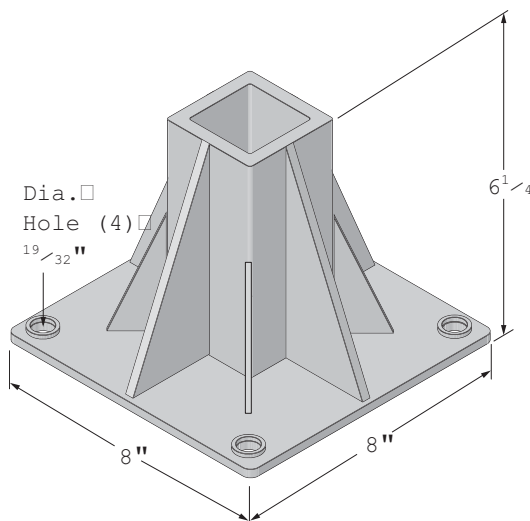
Part No.	Tray Width	Dim. A	Dim. B
CTB06A	06"	11" (279mm)	10" (254mm)
CTB09A	09"	14" (356mm)	12" (305mm)
CTB12A	12"	17" (432mm)	13" (330mm)
CTB18A	18"	23" (584mm)	16" (406mm)
CTB24A	24"	29" (737mm)	19" (483mm)
CTB30A	30"	35" (889mm)	22" (559mm)
CTB36A	36"	41" (1041mm)	25" (635mm)

Instrument & Pipe Stands

Heavy Duty Post Base

20PU-5852 (2" Square), 20PU-5852 RD (2" Round)
20PU-5853 HD (1 $\frac{5}{8}$ " Sq.), 20PU-5854 HD (1 $\frac{1}{2}$ " Sq.),
20PU-5853 (1 $\frac{5}{8}$ " Sq.)

The Aickinstrut heavy duty post base is designed for applications that require a stronger base attachment than the standard Aickinstrut post base. Made from polyurethane, the heavy duty post base is available with four different openings: 1 $\frac{1}{2}$ ", 1 $\frac{5}{8}$ ", 2" square and 2" Schedule 80 round. The heavy duty post base is ideal for mounting fiberglass channel, handrails and instrument stands in corrosive environments. The standard color is gray, but special colors are available upon request.



Instrument & Pipe Stands

Aickin-Instrument and Pipe Stands are available in polyester or vinyl ester resin types and are designed to meet specific customer requirements. These stands are ideal for supporting instruments and enclosures in corrosive environments.

Prefabrication of assemblies is available with customer drawings. Prefabrication saves contractors labor and material costs on the job site.

Structural Shape

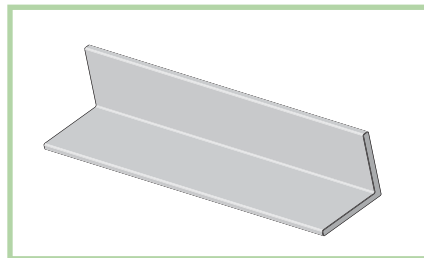
AICKINSHAPE® Structural Shapes

General purpose pultruded structural shapes can be used as a complement to Aickinstrut Channel Framing projects. The shapes are ideal for structural bracing, handrails, handrail kickplates, shims and supporting grating. Structural shapes are available in either polyester or vinyl ester resin and are provided in 20' lengths. Additional structural shapes not listed in this catalog are available. Contact the factory for pricing, availability and minimums. Special sizes and colors can be run based upon quantity.

Note:

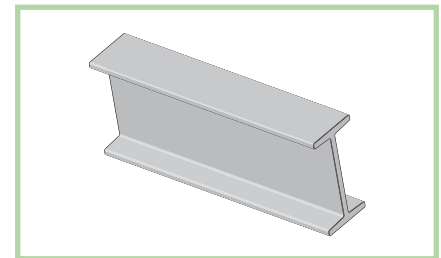
- ST - Standard Isophthalic Polyester Resin; O = (Olive Green)
- FR - Isophthalic Polyester Fire Retardant Resin; P = (Dark Gray)
- VE - Vinyl Ester Fire Retardant Resin; V = (Beige)
 - Stock Item;
 - ◆ Stocked in Yellow
- In part numbers shown below, replace "X" with resin and color code (O, P, V).
- I.E.: 18P-1200-20 Polyester Gray 2" x ¼" Equal Leg Angle
- Subject to availability and minimum order quantity

Equal Leg Angle



Size	Resin			#/Lin. Ft.	Part No.
	ST	FR	VE		
1" x 1/8"	□	□	□	0.21	18X-1100-20
1 1/4" x 1/8"	-	-	-	0.23	18X-1110-20
1 1/2" x 3/16"	□	□	□	0.37	18X-1120-20
1 1/2" x 1/4"	□	□	□	0.51	18X-1130-20
2" x 1/4"	□	□	□	0.68	18X-1200-20
3" x 1/4"	□	□	□	1.04	18X-1300-20
3" x 3/8"	□	□	□	1.65	18X-1310-20
3" x 1/2"	-	-	-	2.15	18X-1320-20
4" x 1/4"	□	□	□	1.41	18X-1400-20
4" x 3/8"	□	□	□	2.23	18X-1410-20
4" x 1/2"	□	□	□	2.92	18X-1420-20
6" x 3/8"	□	□	□	3.44	18X-1500-20
6" x 1/2"	□	□	□	4.50	18X-1510-20

I-Beam



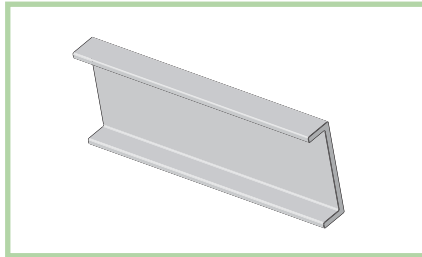
Size	Resin			#/Lin. Ft.	Part No.
	ST	FR	VE		
3" x 2" x 1 1/2" x 1/4"	-	-	-	1.18	18X-2100-20
3" x 1 1/2" x 1/4"	-	-	-	1.11	18X-2300-20
4" x 2" x 1/4"	□	□	□	1.46	18X-2400-20
6" x 3" x 1/4"	□	□	□	2.24	18X-2600-20
6" x 3" x 3/8"	-	-	-	3.29	18X-2800-20
8" x 4" x 3/8"	□	□	□	4.46	18X-2110-20
8" x 4" x 1/2"	-	-	-	5.85	18X-2130-20
10" x 5" x 3/8"	-	-	-	5.78	18X-2160-20
10" x 5" x 1/2"	-	□	□	7.41	18X-2180-20
12" x 6" x 1/2"	-	-	-	8.97	18X-2210-25
18" x 3/8" x 4 1/2" x 1/2"	-	-	-	8.48	18X-2230-20
24" x 3/8" x 7 1/2" x 3/4"	-	-	-	15.2	18X-2240-20



Aickinstrut

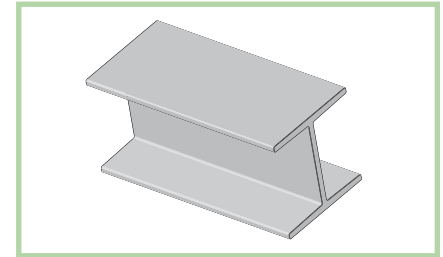
Structural Shape

Channel



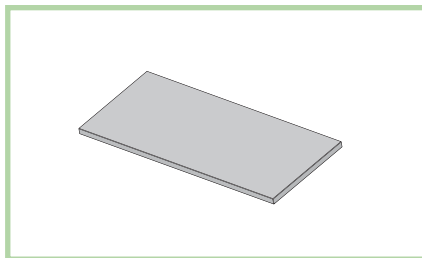
Size (in.)	Resin			#/Lin. Ft.	Part No.
	ST	FR	VE		
2" x 9/16" x 1/8"	☐	☐	-	0.25	18X-2916-20
3" x 7/8" x 1/4"	☐	☐	-	0.77	18X-3078-20
3" x 1" x 1/4"	☐	☐	☐	0.87	18X-3114-20
3" x 1 1/2" x 1/4"		☐	☐	1.07	18X-3112-20
3" x 1/2" x 1 3/16" x 1/8"	-	-	-	0.65	18X-31316-20
4" x 1 1/8" x 1/4"	☐	☐	☐	1.11	18X-4118-20
4" x 1 3/8" x 3/16"	☐	☐	☐	0.86	18X-4138-20
6" x 1 5/8" x 1/4"	☐	☐	☐	1.64	18X-6158-20
6" x 1 1/16" x 3/8"	☐	☐	☐	2.52	18X-61116-20
8" x 2 3/16" x 3/8"	☐	☐	☐	3.40	18X-82316-20
10" x 2 3/4" x 1/2"	☐	☐	☐	5.65	18X-10234-20

Wide Flange I-Beam



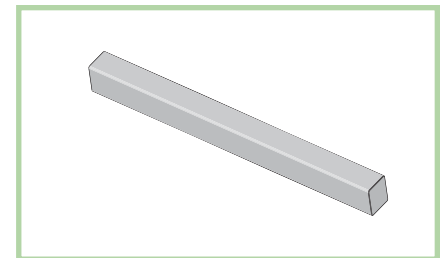
Size (in.)	Resin			#/Lin. Ft.	Part No.
	ST	FR	VE		
3" x 3" x 1/4"	☐	☐	☐	1.69	18X-2200-20
4" x 4" x 1/4"	☐	☐	☐	2.1	18X-2500-20
6" x 6" x 1/4"	☐	☐	☐	3.41	18X-2700-20
6" x 6" x 3/8"	☐	☐	☐	5.05	18X-2900-20
8" x 8" x 3/8"	☐	☐	☐	6.49	18X-2120-20
8" x 8" x 1/2"	-	☐	☐	8.7	18X-2140-20
10" x 10" x 3/8"	-	-	-	8.74	18X-2170-20
10" x 10" x 1/2"	-	☐	☐	10.9	18X-2190-25
12" x 12" x 1/2"	-	☐	☐	13.2	18X-2220-25

Flat Sheet



Size	Resin			#/Lin. Ft.	Part No.
	ST	FR	VE		
1/8" x 48" x 96"	☐	☐	☐	1.14	18X-4100
3/16" x 48" x 96"	☐	☐	☐	1.71	18X-4200
1/4" x 48" x 96"	☐	☐	☐	2.34	18X-4300
3/8" x 48" x 96"	☐	☐	☐	3.54	18X-4400
1/2" x 48" x 96"	☐	☐	☐	4.68	18X-4500
5/8" x 48" x 96"	-	-	-	5.79	18X-4600
3/4" x 48" x 96"	-	-	-	6.94	18X-4700
1" x 48" x 96"	-	-	-	9.27	18X-4800

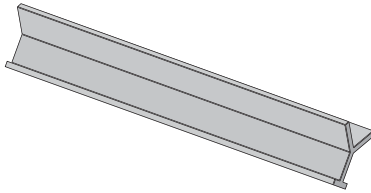
Square Bar



Size (in.)	Resin			#/Lin. Ft.	Part No.
	ST	FR	VE		
1" x 1"	☐	-	-	0.87	18X-5100-20
1 1/4" x 1 1/4"	-	☐	-	1.31	18X-5125-20
1 1/2" x 1 1/2"	-	☐	-	1.98	18X-5150-20
2" x 2"	-	-	-	3.12	18X-5200-20

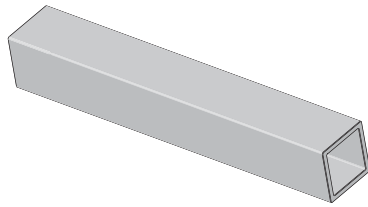
Structural Shape

Embedment Angle



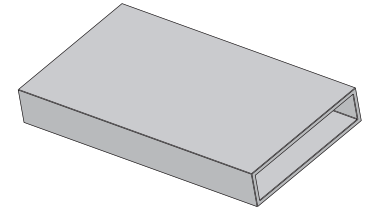
Size	Resin			#/Lin. Ft.	Part No.
	ST	FR	VE		
1" x 1 1/2" x 1/4"	-	-	□	1	18X-111214-20
1 1/2" x 1 1/2" x 1/4"	-	-	□	1.1	18X-11211214-20
2" x 1 1/2" x 1/4"	-	-	□	1.2	18X-211214-20

Square Tube



Size	Resin			#/Lin. Ft.	Part No.
	ST	FR	VE		
1" x 1/8"	□	□	□	0.32	18X-3100-20
1 1/8" x 1/8"	-	-	-	0.37	18X-3200-20
1 1/4" x 1/8"	-	-	-	0.41	18X-3300-20
1 1/4" x 1/4"	-	-	-	0.68	18X-3310-20
1 1/2" x 1/8"	□	□	□	0.54	18X-3400-20
1 1/2" x 1/4"	-	-	□	0.98	18X-3410-20
1 3/4" x 1/8"	-	□	□	0.63	18X-3500-20
1 3/4" x 1/4"	-	□	□	1.1	18X-3510-20
2" x 1/8"	□	□	□	0.69	18X-3600-20
2" x 1/4"	□	□	□	1.4	18X-3610-20
2 1/4" x 1/8"	-	□	-	0.83	18X-3800-20
2 1/4" x 1/4"	-	-	-	1.56	18X-3810-20
2 1/2" x 1/4"	-	□	-	1.79	18X-3900-20
3" x 1/8"	-	-	-	1.12	18X-3110-20
3" x 1/4"	□	□	□	2.15	18X-3111-20
4" x 1/4"	□	□	□	2.93	18X-3120-20
4" x 3/8"	□	-	-	4.24	18X-3121-20
6" x 3/8"	□	□	□	6.42	18X-3140-20

Rectangular Tube

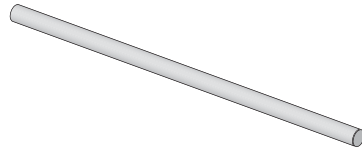


Size	Resin			#/Lin. Ft.	Part No.
	ST	FR	VE		
4" x 1" x 1/8"	-	-	-	0.85	18X-4118-20
4" x 1/8" x 2" x 1/4"	□	□	□	1.52	18X-418214-20
4 3/8" x 1 3/8" x 1/8" x 3/16"	-	-	-	1.18	18X-438138-20
4 1/2" x 1 3/4" x 1/8" x 3/16"	-	-	-	1.29	18X-412138-20
5" x 2" x 1/8"	-	-	-	1.32	18X-5218-20
5 1/8" x 2 1/8" x 3/16"	-	-	-	1.32	18X-518218-20
6 1/2" x 1/4" x 2" x 1/2"	-	-	-	3.77	18X-612212-20
6" x 4" x 1/4"	-	□	-		18X-6414-20

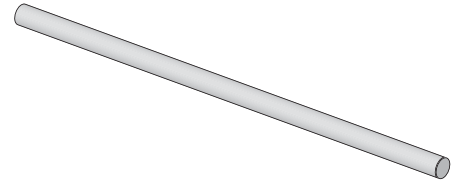
Aickinstrut

Structural Shape

Round Rod



Round Tube



Size	Resin			#/Lin. Ft.	Part No.
	ST	FR	VE		
1/8"	☐	-	-	0.01	18X-70018-20
3/16"	☐	-	-	0.02	18X-700316-20
1/4"	☐	-	-	0.04	18X-70014-20
5/16"	☐	-	-	0.07	18X-700516-20
0.35"	-	-	-	0.08	18X-70035-20
3/8"	☐	-	☐	0.09	18X-70038-20
1/2"	☐	-	☐	0.17	18X-70012-20
5/8"	☐	-	☐	0.27	18X-70058-20
3/4"	☐	-	☐	0.39	18X-70034-20
13/16"	-	-	-	0.46	18X-7001316-20
1"	☐	-	☐	0.66	18X-70100-20
1 1/4"	☐	-	-	1.08	18X-70114-20
1 1/2"	☐	-	-	1.56	18X-70112-20
2"	-	-	-	2.56	18X-70200-20
2 1/2"	-	-	-	4.10	18X-70212-20
3"	-	-	-	5.70	18X-70300-20

Size	Resin			#/Lin. Ft.	Part No.
	ST	FR	VE		
1" x 0.1"	-	-	-	0.22	18X-7100-20
1" x 1/8"	☐	☐	-	0.25	18X-7118-20
1 1/4" x 3/32"	-	-	-	0.27	18X-7114332-20
1 1/4" x 1/8"	-	-	-	0.32	18X-711418-20
1 1/4" x 1/4"	-	-	-	0.6	18X-711414-20
1 1/2" x 1/8"	☐	☐	-	0.45	18X-711218-20
1 1/2" x 1/4"	-	☐	-	0.79	18X-711214-20
1 3/4" x 1/8"	-	-	-	0.47	18X-713418-20
1 3/4" x 1/4"	-	-	-	0.94	18X-713414-20
2" x 1/4"	☐	☐	☐	1.12	18X-7214-20
3" x 0.1"	-	-	-	0.89	18X-7300-20
3" x 1/4"	-	-	-	1.68	18X-7314-20
3" x 1/2"	☐	-	-	2.98	18X-7312-20
4.89" x 1/8"	-	-	-	2.32	18X-7418-20
4.89" x 3/16"	-	-	-	2.97	18X-74316-20

FEATURES

SWAGE

I-BEAM

TROF

EAGLE BASKET

CHANNEL

GLAS

AICKINSTRUT

DATA

REFERENCE DATA

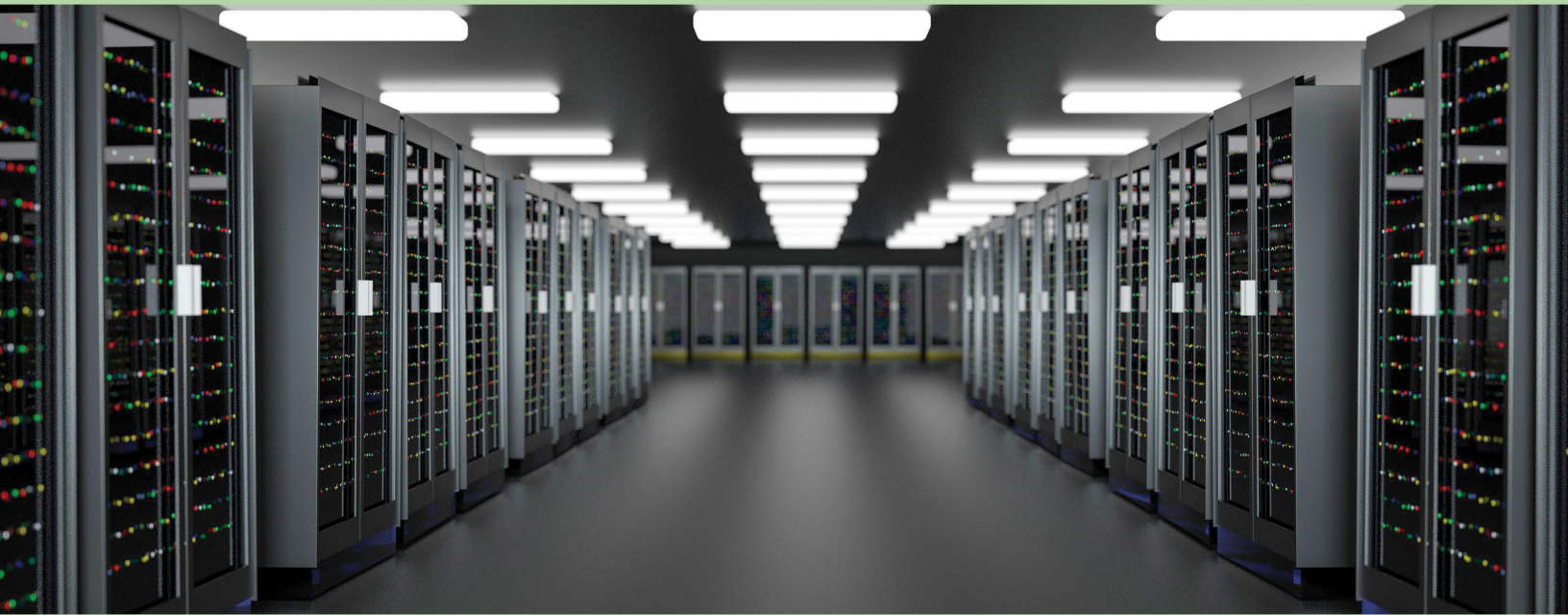


Table Of Conversions

English to Metric			Metric to English		
To Convert From	To	Multiply By	To Convert From	To	Multiply By
Length					
Inch [in]	Millimeter [mm]	25.400 000	Millimeter [mm]	Inch [in]	0.039 370
Foot [ft]	Meter [m]	0.304 800	Meter [m]	Foot [ft]	3.280 840
Yard [yd]	Meter [m]	0.914 400	Meter [m]	Yard [yd]	1.093 613
Mile (U.S. Statute) [mi]	Kilometer [km]	1.609 347	Kilometer [km]	Mile (U.S. Statute) [mi]	0.621 370
Area					
Square Inch [in ²]	Square Millimeter [mm ²]	645.16	Square Millimeter [mm ²]	Square Inch [in ²]	0.001550
Square Foot [ft ²]	Square Meter [m ²]	0.092 903	Square Meter [m ²]	Square Foot [ft ²]	10.763 915
Square Yard [yd ²]	Square Meter [m ²]	0.836 127	Square Meter [m ²]	Square Yard [yd ²]	1.195 991
Square Mile [mi ²] (U.S. Statute)	Square Kilometer [km ²]	2.589 998	Square Kilometer [km ²]	Square Mile [mi ²] (U.S. Statute)	0.386 101
Acre	Square Meter [m ²]	4.046 873	Square Meter [m ²]	Acre	0.000 247
Acre	Hectare	0.404 687	Hectare	Acre	2.471 046
Volume					
Cubic Inch [in ³]	Cubic Millimeter [mm ³]	16,387.06	Cubic Millimeter [mm ³]	Cubic Inch [in ³]	0.000061
Cubic Foot [ft ³]	Cubic Meter [m ³]	0.028 317	Cubic Meter [m ³]	Cubic Foot [ft ³]	35.314 662
Cubic Yard [yd ³]	Cubic Meter [m ³]	0.764 555	Cubic Meter [m ³]	Cubic Yard [yd ³]	1.307 950
Gallon (U.S. Liquid) [gal]	Litre [l]	3.785 412	Litre [l]	Gallon (U.S. Liquid) [gal]	0.264 172
Quart (U.S. Liquid) [qt]	Litre [l]	0.946 353	Litre [l]	Quart (U.S. Liquid) [qt]	1.056 688
Mass					
Ounce (Avoirdupois) [oz]	Gram [g]	28.349 520	Gram [g]	Ounce (Avoirdupois) [oz]	0.035 274
Pound (Avoirdupois) [lb]	Kilogram [kg]	0.453 592	Kilogram [kg]	Pound (Avoirdupois) [lb]	2.204 624
Short Ton	Kilogram [kg]	907.185	Kilogram [kg]	Short Ton	0.00110
Force					
Ounce-Force	Newton [N]	0.278 014	Newton [N]	Ounce-Force	3.596 941
Pound-Force [lbf]	Newton [N]	4.448 222	Newton [N]	Pound-Force [lbf]	0.224 809
Bending Moment					
Pound-Force-Inch [lbf-in]	Newton-Meter [N-m]	0.112 985	Newton-Meter [N-m]	Pound-Force-Inch [lbf-in]	8.850 732
Pound-Force-Foot [lbf-ft]	Newton-Meter [N-m]	1.355 818	Newton-Meter [N-m]	Pound-Force-Foot [lbf-ft]	0.737 562
Pressure, Stress					
Pound-Force per Square Inch [lbf/in ²]	Kilopascal [kPa]	6.894 757	Kilopascal [kPa]	Pound-Force per Square Inch [lbf/in ²]	0.145 038
Foot of Water (39.2 F)	Kilopascal [kPa]	2.988 980	Kilopascal [kPa]	Foot of Water (39.2 F)	0.334 562
Inch of Mercury (32 F)	Kilopascal [kPa]	3.386 380	Kilopascal [kPa]	Inch of Mercury (32 F)	0.295 301
Energy, Work, Heat					
Foot-Pound-Force [ft-lbf]	Joule [J]	1.355 818	Joule [J]	Foot-Pound-Force [ft-lbf]	0.737 562
British Thermal Unit [Btu]	Joule [J]	1,055.056	Joule [J]	British Thermal Unit [Btu]	0.000948
Calorie [cal]	Joule [J]	4.186 800	Joule [J]	Calorie [cal]	0.238 846
Kilowatt Hour [kW-h]	Joule [J]	3,600,000	Joule [J]	Kilowatt Hour [kW-h]	2.78 ⁻⁷
Power					
Foot-Pound-Force /Second [ft-lbs/s]	Watt [W]	1.355 818	Watt [W]	Foot-Pound-Force /Second [ft-lbs/s]	0.737 562
British Thermal Unit /Hour [Btu/h]	Watt [W]	0.293 071	Watt [W]	British Thermal Unit /Hour [Btu/h]	3.412 142
Horsepower (550 Ft. Lbf/s) [hp]	Kilowatt [kW]	0.745 700	Kilowatt [kW]	Horsepower (550 Ft. Lbf/s) [hp]	1.341 022
Angle					
Degree	Radian [rad]	0.017 453	Radian [rad]	Degree	57.295 788
Temperature					
Degree Fahrenheit [F]	Degree Celsius [C]	(F° -32)/1.8	Degree Celsius [C]	Degree Fahrenheit [F]	1.8xC°+32



Tray Fill Charts

Cable Tray/Eagle Basket Loadings Reference

NEMA (VE-1) Loadings¹

Tray/Load Designation	Class A	Class B	Class C
lbs/ft	50	75	100

Power Cables^{1,2}

Tray Dimension	36" Wide	30" Wide	24" Wide	18" Wide	12" Wide	9" Wide	6" Wide
Cable Fill Weight	140	115	90	70	45	35	25

Data/Communication Cables^{1,3,4}

Tray Size	36" Wide	30" Wide	24" Wide	18" Wide	12" Wide	9" Wide	6" Wide
6" Depth	89	74	59	45	30	23	15
5" Depth	74	62	49	37	25	19	13
4" Depth	59	49	40	30	20	15	10
3" Depth	45	37	30	23	15	12	8
2" Depth	30	25	20	15	10	8	5

Note:

1. All Cable Weight/Loads are in Lbs/ft unless otherwise noted.
2. Larger diameter cables used in weight estimation.
3. Max 50% fill ratio used in calculations for Data/Communication Cables
4. CAT6/CAT6E cables, O.D. = 0.25" nominal, weight = 0.040 lbs/ft

Corrosion Resistance Guide

The symbols to the right have been used throughout the table in order to provide an indication about the suitability of a potential candidate material for a specific chemical environment.

Note: These tables should be regarded only as GUIDES to anticipated performance because of possible contributions from temperature, pollutant (contaminant) species, etc.

SYMBOLS:

++	First choice; very low corrosion rate, typically <5 mpy, or <0.005 Inch/year, (1 mil = 1/1000 inch).
+	Good choice; low corrosion rate, typically <20 mpy, or <0.02 lpy.
-	Can use; corrosion rate up to 50 mpy (0.05 lpy); some limitations may apply.
X	Not recommended.
(-)	Brackets indicate probable limitations, E.G., At higher temperatures, [symbol "T"]; at higher concentrations, [symbol "C"]; due to pitting, [symbol "P"]; due to local grain boundary attack in the metal - intergranular corrosion, [symbol "I"]; due to stress corrosion cracking, [symbol "S"].
nd	No available data

Corrosion Resistance Guide			
Chemical Species	Aluminum	HDG/Steel	316SS
Acetaldehyde	++	+	++
Acetic acid - aerated	(+) ^{TC}	X	(++) ^T
Acetic acid - not aerated	(+) ^{TC}	X	(++) ^T
Acetone	++	++	++
Acetylene	++	nd	++
Allyl alcohol	+	nd	++
Aluminum chloride - dry	+	nd	(+) ^{TP}
Aluminum chloride - wet	X	X	(-) ^P
Aluminum sulfate - satd.	X	nd	+
Ammonia - anhydrous	++	++	++
Ammonia - gas	-	+	(+) ^T
Ammonium acetate	+	nd	+
Ammonium bicarbonate	-	nd	(+) ^T
Ammonium carbonate - satd.	+	X	+
Ammonium chloride - 28%	X	X	(#) ^S
Ammonium chloride - 50%	X	X	X
Ammonium hydroxide	+	+	(++) ^C
Ammonium nitrate	+	X	(++) ^S
Ammonium phosphate - 40%	X	nd	+
Ammonium sulfate - to 30%	X	-	+
Amyl acetate	++	++	++
Asphalt	++	+	+
Beer	++	X	++
Benzene (benzol)	++	+	(+) ^P
Benzoic acid	+	nd	+
Benzol - see benzene	++	nd	(++) ^P
Boric acid (boracic acid)	++	nd	(++) ^P
Bromine - wet	X	X	X
Butadiene (butylene)	+	+	+
Butyl alcohol (butanol)	++	++	++
Butyric acid	+	X	+
Cadmium sulfate	+	nd	++

Corrosion Resistance Guide			
Chemical Species	Aluminum	HDG/Steel	316SS
Calcium carbonate	-	nd	+
Calcium chloride - satd.	+	X	(+) ^S
Calcium hydroxide - satd.	X	nd	+
Calcium hypochlorite - satd.	X	X	(#)
Carbon dioxide - wet	++	+	+
Carbon disulfide (bisulfide)	++	+	++
Carbon tetrachloride	X	+	(++) ^{PS}
Carbolic acid - see phenol			
Carbonic acid - see carbon dioxide			
Caustic potash - see potassium hydroxide	X	++	(-) ^{PS}
Caustic soda - see sodium hydroxide			
Chlorine gas - wet			
Chloroform	(+) ^{dry}	+	(+) ^{TS}
Chromic acid	+	nd	(+) ^P
Citric acid - dilute	(+) ^{TC}	X	(++) ^P
Copper chloride	X	X	(-) ^P
Copper nitrate	X	nd	++
Copper sulfate	X	-	+
Cresol	+	+	+
Crude oil	++	++	++
Diethylamine	+	++	++
Dimethyl ketone - see acetoneEthyl acetate	(#) ^T	++	+
Ethyl alcohol (ethanol)	++	++	++
Ethylene dichloride	(-) ^{dry}	++	(+) ^{PS}
Ethylene glycol (glycol)	++	++	++
Ferric chloride	X	X	X
Ferric nitrate - 10%	X	nd	+
Ferrous sulfate	+	nd	(+) ^P
Formaldehyde (methanal)	(#)	++	(++) ^C
Fluorine gas - moist	X	X	X
Formalin - see formaldehydeFormic acid (methanoic acid) - 10%	(+) ^T	X	(+) ^{PC}
Furfural (furfuraldehyde)	+	nd	+



Corrosion Resistance Guide

Corrosion Resistance Guide			
Chemical Species	Aluminum	HDG/Steel	316SS
Furool - see furfural Gelatin	++	+	++
Glycerine (glycerol)	++	++	++
Hexamine - 80%	++	nd	++
Hydrobromic acid	X	X	X
Hydrochloric acid (muriatic acid)	X	X	X
Hydrocyanic acid - dilute	+	nd	+
Hydrocyanic acid - conc	X	nd	+
Hydrofluoric acid	X	X	X
Hydrogen chloride gas - dry	X	X	(+ F)
Hydrogen chloride gas - wet	X	X	+
Hydrogen fluoride	(-) ^T	nd	+
Hydrogen peroxide - to 40%	++	nd	+
Hydrogen sulfide - wet	(+) ^P	nd	(+) ^{PS}
Hypo - see sodium thiosulfate Hypochlorous acid	X	X	X
Iodine solution - satd	X	X	X
Lactic acid	(+) ^T	nd	(+) ^J
Latex	++	-	++
Lithium chloride - to 30%	X	nd	++
Linseed oil	+	nd	++
Magnesium chloride - 50%	X	X	(+) ^S
Magnesium hydroxide	+	nd	++
Magnesium sulfate	+	X	+
Maleic acid (maleinic acid) - 20%	+	nd	+
Methyl alcohol (methanol)	++	++	++
Methyl ethyl ketone	+	++	+
Milk	++	X	++
Molasses	+	nd	++
Naptha	+	+	+
Natural fats	++	++	++
Nickel chloride	X	nd	(+) ^{PS}
Nickel sulfate	X	nd	+
Nitric acid	X	X	(++)
Oleic acid	(++) ^T	nd	++
Oxalic acid - dilute	-	nd	+
Oxalic acid - saturated	(+) ^T	X	X
Paraformaldehyde - to 30%	+	nd	++
Perchloroethylene	+	X	(++)
Phenol (carbolic acid)	+	+	++
Phosphoric acid - dilute	X	X	++
Phosphoric acid - 50%	X	X	(++)
Picric acid	++	nd	+
Potassium bicarbonate - 30%	X	nd	++
Potassium carbonate	X	nd	++
Potassium chloride - to 25%	X	X	(+ F)

Corrosion Resistance Guide			
Chemical Species	Aluminum	HDG/Steel	316SS
Potassium dichromate - 30%	(+ F)	X	++
Potassium hydroxide	X	nd	(+) ^S
Potassium nitrate	++	++	+
Potassium sulfate	++	++	++
Propionic acid (propanoic acid)	(F)	X	(+) ^T
Propyl alcohol (propane)	++	++	++
Prussic acid - see hydrocyanic acid Pyridine	+	nd	++
Soaps	+	-	+
Sodium bicarbonate - 20%	+	nd	++
Sodium bisulfate	X	X	(+) ^T
Sodium bisulfite	X	X	+
Sodium chloride - to 30%	X	X	(+) ^{PS}
Sodium cyanide	X	nd	(+) ^T
Sodium hydroxide - 10-30%	X	X	(+ S)
Sodium hydroxide - 50%	X	X	(++) ^S
Sodium hydroxide - conc	X	X	++
Sodium hypochlorite - conc	X	+	(PS)
Sodium nitrate	++	X	++
Sodium peroxide - 10%	+	nd	+
Sodium silicate	++	nd	++
Sodium sulfate	(++) ^{30%}	X	++
Sodium sulfide - to 50%	X	nd	(+) ^T
Sodium thiosulfate	+	nd	++
Steam	(+) ^P	++	++
Stearic acid	+	nd	++
Sorbital (hexahydric alcohol)	++	+	++
Sulfur dioxide - dry	+	+	++
Sulfur dioxide - wet	X	X	(+) ^T
Sulfuric acid - to 80%	X	X	X
Sulfuric acid - 80-90%	X	X	(-) ^I
Sulfuric acid - 98%	X	X	(+) ^I
Tannic acid (tannin)	X	X	+
Tartaric acid - to 50%	(+) ^T	nd	++
Toluene (Toluol; methyl benzene)	++	++	+ F
Trichloroethylene	(++) ^T	+	(+) ^P
Turpentine	+	++	++
Water - acid, mine	X	-	(++) ^P
Water - potable	+	+	++
Water - sea	+	+	++
Xylene	++	nd	++
Zinc chloride - dilute	++	nd	(++) ^{PS}

Note: These tables should be regarded only as GUIDES to anticipated performance because of possible contributions from temperature, pollutant (contaminant) species, etc.

Fractions & Decimal Equivalents

	1/64	0.015625		33/64	0.515625
	1/32	0.03125		17/32	0.53125
	3/64	0.046875		35/64	0.546875
	1/16	0.0625		9/16	0.5625
	5/64	0.078125		37/64	0.578125
	3/32	0.09375		19/32	0.59375
	7/64	0.109375		39/64	0.609375
	1/8	0.125		5/8	0.625
	9/64	0.140625		41/64	0.640625
	5/32	0.15625		21/32	0.65625
	11/64	0.171875		43/64	0.671875
	3/16	0.1875		11/16	0.6875
	13/64	0.203125		45/64	0.703125
	7/32	0.21875		23/32	0.71875
	15/64	0.234375		47/64	0.734375
	1/4	0.25		3/4	0.75
	17/64	0.265625		49/64	0.765625
	9/32	0.28125		25/32	0.78125
	19/64	0.296875		51/64	0.796875
	5/16	0.3125		13/16	0.8125
	21/64	0.328125		53/64	0.828125
	11/32	0.34375		27/32	0.84375
	23/64	0.359375		55/64	0.859375
	3/8	0.375		7/8	0.875
	25/64	0.390625		57/64	0.890625
	13/32	0.40625		29/32	0.90625
	27/64	0.421875		59/64	0.921875
	7/16	0.4375		15/16	0.9375
	29/64	0.453125		61/64	0.953125
	15/32	0.46875		31/32	0.96875
	31/64	0.484375		63/64	0.984375
	1/2	0.5		1	1.



Data

Index

C-Channel Swage Ladder - Part Number Index

Part Number	Page	Part Number	Page
9038.....	54	7-HGR1.....	54
9043.....	53	8-9053.....	52
9053.....	52	8-HGR1.....	54
9131.....	52	9025-98.....	53
9132.....	52	9036-31.....	54
9133.....	52	9036-37.....	54
9156.....	48	9036-45.....	54
06BE.....	48	9037-12.....	54
06CB.....	48	9037-18.....	54
06DO.....	48	9037-24.....	54
06SL.....	45	9037-30.....	54
09BE.....	48	9037-36.....	54
09CB.....	48	9037-42.....	54
09DO.....	48	9043-37.....	53
09SL.....	45	9056-EP.....	49
12BE.....	48	9056-SS.....	49
12CB.....	48	9057-EP.....	49
12DO.....	48	9057-SS.....	49
12SL.....	45	9131A.....	52
18BE.....	48	9131-HDW.....	52
18CB.....	48	9131-IP.....	53
18DO.....	48	9131L.....	52
18SL.....	45	9F.....	28
24BE.....	48	9I.....	39
24CB.....	48	9O.....	39
24DO.....	48	AF.....	38
24SL.....	45	BE.....	48
30BE.....	48	BSP.....	51
30CB.....	48	CA.....	42
30DO.....	48	CB.....	48
30SL.....	45	CBJ.....	48
36BE.....	48	CBJ-250C.....	48
36CB.....	48	CBJ-4C.....	48
36DO.....	48	CBJ-C.....	48
36SL.....	45	CC.....	47
3F.....	29	CCB-050.....	49
3I.....	40	CCB-075.....	49
3O.....	40	CCB-100.....	49
4F.....	29	CCB-125.....	49
4I.....	40	CCB-150.....	49
4O.....	40	CCB-200.....	49
5003-1.....	43	CCS.....	47
5009-1.....	43	CCS-SS.....	45
6-9053.....	52	CD.....	42
6F.....	28	CE.....	42
6I.....	39	CE-MID.....	42
6O.....	39	CH.....	42

FEATURES

SWAGE

I-BEAM

TROF

EAGLE BASKET

CHANNEL

GLAS

AICKINSTRUT

DATA



Index

C-Channel Swage Ladder - Part Number Index

Part Number	Page	Part Number	Page
CO	43	NF.....	44
CV.....	42	NL.....	44
DC.....	46	OB.....	51
DO	48	OT	41
EM.....	43	P200.....	55
EM-CC.....	47	PC.....	46
FB.....	50	PF.....	44
FC	31	PH	44
FL	44	PS.....	44
FS.....	44	PV	44
FT	30	RC.....	42
GCC.....	53	RH	36
HS.....	44	RY.....	38
HV	44	SB.....	50
IB	51	SB-HDW	51
JP-06	45	SCC.....	53
JP-09	45	SL.....	22
JP-12	45	SR.....	41
JP-120.....	45	SS89042.....	49
JP-18.....	45	ST	37
JP-24	45	T200E	55
JP-30.....	45	T201E.....	55
JP-36.....	45	TC.....	34-35
LH.....	36	TT.....	32-33
LY.....	38	VC.....	46
		VT.....	41



Data

Index

C-Channel Swage Ladder - Keyword Index

Description	Page
30° Horizontal Elbow.....	29
30° Vertical Elbow Inside.....	40
30° Vertical Elbow Outside	40
45° Horizontal Elbow	29
45° Vertical Elbow Inside.....	40
45° Vertical Elbow Outside.....	40
45° Y Branch Left Hand	38
45° Y Branch Right Hand.....	38
60° Horizontal Elbow	28
60° Vertical Elbow Inside	39
60° Vertical Elbow Outside.....	39
90° Angle Connector	42
90° Horizontal Elbow	28
90° Vertical Cable Support Elbow	41
90° Vertical Elbow Inside	39
90° Vertical Elbow Outside.....	39
Accessories	48-49, 52-53
Adjustable Elbow	38
Barrier Strip - Horizontal Fitting.....	50
Barrier Strip - Straight Section	50
Barrier Strip Clamp.....	51
Barrier Strip Vertical Elbow Inside	51
Barrier Strip Vertical Elbow Outside.....	51
Barrier Strips	50-51
Blind End.....	48
Bonding Jumper.....	48
Box Connector.....	48
Cable Clamp.....	53
Cable Tray Ground Clamp.....	48
Combination Hold-Down Clamp	52
Conduit Clamp Bracket	49
Connector Hardware	43
Connector Plates.....	42-43
Cover Accessories.....	46-47
Cover Connector.....	47
Cover Screw.....	43
Covers.....	44-45
CSA System Selection Chart.....	26
Double Clamp Connector	46
Drop Out	48
Electrical Grounding Chart.....	24
Electro-Galv Steel Cover Clip.....	47
Elevated Cover Connectors.....	47
Expansion Connector	42
Fittings	27
Flanged Louvered	44
Flanged Solid.....	44
Flat Louvered	44

Description	Page
Flat Solid.....	44
Ground Cable Retainer Clamp	49
Hardware	43
Hat Solid	44
Hat Vent.....	44
Horizontal Adjustable Connector	42
Horizontal Cross	31
Horizontal Tapped Cross	34-35
Horizontal Tapped Tee	32-33
Horizontal Tee	30
Isolation Pad	53
Joint Plate.....	45
Left Hand Reducer.....	36
Mid-Span Expansion Plate.....	42
Mid-Span Splice Plate	42
Nylon Barrier Splice & Protector.....	51
Part Numbering System.....	21
Peak Cover Connector	46
Peak Vent Cover Connector	46
Peaked Flanged Solid.....	44
Peaked Hat Solid	44
Peaked Hat Vent.....	44
Peaked Solid.....	44
Reducing Connector	43
Right Hand Reducer	36
Seismic Hold-Down.....	52
Single Ladder Hangers.....	54
Single Rod Hanger Support.....	55
Specifications.....	25
Stainless Steel Cover Clip.....	45
Steel Tray	42-43
Stepdown Connector	42
Straight Length.....	22-23
Straight Reducer.....	37
Structural Support Bracket.....	54
Support Brackets & Tray Hangers	53-54
Trapeze Hanger Support.....	55
Tray Hanger & Supports	55
Tray Hangers	54
Universal Aluminum Barrier Strip.....	50
Universal Curvilinear Connector	42
Vertical Adjustable Connector	42
Vertical Supports.....	53
Vertical Tee - Down	41
Vertical Tee - Up.....	41
Wall Penetrating Sleeve Assembly	49
Wall Support Brackets	54

Index

I-Beam - Part Number Index

Part Number	Page
30H.....	65
30VI.....	67
30VO.....	67
45H.....	65
45VI.....	67
45VO.....	67
60H.....	65
60VI.....	67
60VO.....	67
90H.....	65
90VI.....	67
90VO.....	67
BC-A.....	78
BE-A.....	78
BSE.....	67
CAB.....	76
CAC.....	76
CB-A.....	69
CCEF.....	71
CCP-A6.....	74
CCR-A.....	71
CCS-S.....	71
CFS.....	71
CJF.....	71
CJP.....	71
CPS.....	71
CS-A.....	71
CSE.....	67
DCD.....	66
DCDE.....	66
DCDR.....	66
DCU.....	66
DCUE.....	66
DCUR.....	66
DF.....	68
DFH.....	68
DH.....	68
DHC-A-S.....	69
DS.....	68
DSH.....	68
DTD.....	66
DTDE.....	66
DTDR.....	66
DTU.....	66
DTUE.....	66
DTUR.....	66
DVS.....	68
F-CNS-12.....	81
F-CNS-14.....	81
F-CNS-38.....	81

Part Number	Page
F-CNW-12.....	81
F-CNW-14.....	81
F-CNW-38.....	81
F-EB-38-5-S.....	67
F-FHN-12.....	81
F-FHN-14.....	81
F-FHN-38.....	81
F-FRW-12.....	81
F-FRW-14.....	81
F-FRW-38-S.....	81
FFS.....	70
FFV.....	70
F-HBC-12.....	81
F-HBC-14.....	81
F-HBC-38.....	81
F-HHB-12-15.....	81
F-HHB-14-15.....	81
F-HHB-38-15.....	81
F-LHN-38-S.....	81
FNS.....	70
FNV.....	70
F-PRS-38-34-S.....	81
F-RCN-12.....	81
F-RCN-14.....	81
F-RCN-38.....	81
F-RNS-38-34.....	81
F-SCW-12.....	81
F-SCW-14.....	81
F-SCW-38.....	81
F-SDS-10-1-S.....	81
F-SHN-12.....	81
F-SHN-38.....	81
F-SNC-14-34.....	81
F-SNC-14-5-Z.....	81
F-SNC-14-6-Z.....	81
F-SNC-14-7-Z.....	81
F-SNC-14-8-Z.....	81
F-SRS-14-15.....	81
F-SRS-38-15.....	81
F-THR-12-144.....	81
F-THR-14-72.....	81
F-THR-38-144.....	81
F-THS-14-6.....	81
F-THS-14-7.....	81
F-THS-14-8.....	81
F-THS-14-9.....	81
GBJ-C-1000.....	74
GBJ-C-1200.....	74
GBJ-C-1600.....	74
GBJ-C-2000.....	74



Index

I-Beam - Part Number Index

Part Number	Page
GBJ-C-600	74
GBJ-C-800	74
GWC-A1-Z	74
GWL-A-Z	74
GWS-S-1	74
HAE	65
HBF-A	76
HBT-A	76
HC	66
HCC	80
HCD	80
HCR	66
HCS	80
HDH-A	75
HDL-A	75
HEB-H	75
HHB-H	75
HRC-Z	76
HT	66
HTE	66
HTR	66
HYL	65
HYR	65
HYS	65
LD-A	79
NP-32-12	78
NP-36	78
NR-18-2	77
PFS	70
RB-A	79
RHP-A	77
RL	65
RR	65
RRL-A	78
RRM-A	78
RRS-A	78
RS	65
SHH	72
SL	60
SPB	72
SPC	73
SPD	73
SPE	72
SPFS-A	73
SPH	72
SPM	72
SPP	73
SPR	72
SPS	72
SPV	72

Part Number	Page
SVH	72
VC	66
VTD	66
VTU	66
WBD-H	80
WBH-H	80
WBS-H	80
WPS	77

I-Beam - Keyword Index

Description	Page
30° Horizontal Elbow	65
30° Vertical Elbow Inside	67
30° Vertical Elbow Outside	67
45° Horizontal Elbow	65
45° Vertical Elbow Inside	67
45° Vertical Elbow Outside	67
60° Horizontal Elbow	65
60° Vertical Elbow Inside	67
60° Vertical Elbow Outside	67
90° Cable Support Elbow	67
90° Horizontal Elbow	65
90° Vertical Elbow Inside	67
90° Vertical Elbow Outside	67
Accessories	77-80
Adjustable Horizontal Elbow	65
Aluminum Cover Joint Strip	71
Beam Clamp	81
Blind End Ladder Plate	78
Blind End Solid Plate	78
Bonding and Grounding	74
Bonding Jumpers	74
Box Connector	72, 78
Branch Pivot Connectors	73
Cable Bridge for Divided Tees & Crosses	69
Cable Tray Cross-Section	60
Cable Tray Straight Sections - Aluminum	61
Channel Nut, Without Spring	81
Conduit Attachment Bracket & Clamp	76
Conduit Connector Plate	74
Conversion Plate	73
Cope Part Numbering System	61
Cover Clips Horizontal Use	71
Cover Clips Indoor Use	71
Cover Connectors	71
Cover Support Brace	71
Covers	70

Index

I-Beam - Keyword Index

Description	Page
Divider Splice	68
Dividers.....	68-69
Dropout Cross w/ Vertical Riser Taps ...	66
Dropout Tee with Vertical Riser Tap.....	66
Elevated Cover Clamp.....	71
Expanded Metal Bottoms	61
Expansion Plate	72
Eye Bolt Kit.....	67
Fasteners & Hardware	81
Flanged Hex Nut.....	81
Flat Round Washer	81
Flat Strap Cover Clamp.....	71
Flat, Flanged, Solid Cover	70
Flat, Flanged, Ventilated Cover.....	70
Flat, Non-Flanged, Solid Cover.....	70
Flat, Non-Flanged, Ventilated Cover	70
Floor Support Brackets.....	73
Ground Wire Clamp	74
Ground Wire Lay-in Lug.....	74
Ground Wire Support Clamp.....	74
Hanger Channels.....	80
Hanger Rod Clamp	76
Hex Bolt	81
Hold Down Brackets.....	76
Hold Down Clamp & Expansion Guide .	75
Hold Down Clamps	75-76
Horizontal Adjustable Plate	72
Horizontal Cross	66
Horizontal Elbows.....	65
Horizontal Flexible Divider	68
Horizontal Tee	66
Horizontal Trays	72
Ladder Cable Dropout.....	79
Left - Hand Reducer	65
Locking Hex Nut	81
Marine Rungs.....	61
Mid-Span Plate.....	72
Neoprene Roll	77
Nylon Pads.....	78
Offset Reducing Plate.....	72
Peaked 20°, Flanged, Solid Cover	70
Peaked Strap Cover Clamp.....	71
Rain Hood for Wall Penetration Sleeve.	77
Raised Cover Clip	71
Reducers	65
Replacement Rungs	78
Ribbed Neck Screw.....	81
Right - Hand Reducer	65

Description	Page
Rod Coupler Nut.....	81
Roof Block Support	79
Self-Drilling Screw.....	81
Slotted, Round-Head Screw.....	81
Solid Bottoms.....	60
Splice Plates	63
Splices & Connectors	72-74
Spring Nut.....	81
Square Channel Washer.....	81
Square-Neck Carriage Bolt	81
Standard Hex Nut.....	81
Standard Ladders.....	60
Standard Splice Plates.....	72
Step-Down (Reducing Height).....	73
Straight - Heavy Duty Divider	68
Straight Divider	68
Straight Reducer.....	65
Strut Rungs.....	61
Tees and Crosses.....	66
Threaded Rod.....	81
Threaded Stud	81
U-Bolt Divider Clamp Kit.....	69
Ventilated/Trof	60
Vertical Adjustable Plate	72
Vertical Elbow Divider	68
Vertical Elbows	67
Vertical Outdoor Cover Clamps.....	71
Vertical Tee	66
Vertical Trays.....	72
Wall Brackets.....	80
Wall Penetration Sleeve	77
WYE - Left Horizontal Elbow	65
WYE - Right Horizontal Elbow.....	65
WYE Straight Horizontal Elbow	65



Index

Trof - Part Number Index

Part Number	Page
01CC.....	114
3F.....	99
3I.....	109
3O.....	109
4F.....	99
4I.....	109
4O.....	109
5003.....	112
5003-1.....	112
5009.....	112
5009-1.....	112
50172.....	119
6F.....	98
6I.....	108
6O.....	108
9025-98.....	121
9036-31.....	120
9036-37.....	120
9036-45.....	120
9037-12.....	120
9037-18.....	120
9037-24.....	120
9037-30.....	120
9037-36.....	120
9037-42.....	120
9039.....	119
9040.....	119
9041.....	119
9042.....	119
9043.....	121
9043-37.....	121
9045.....	121
9056-EP.....	116
9056-SS.....	116
9057-EP.....	116
9057-SS.....	116
9132.....	119
9156.....	116
9F.....	98
9I.....	108
9O.....	108
AF.....	107
BE.....	116
BSP.....	118
CA.....	111
CB.....	116
CBJ.....	117
CC.....	115

Part Number	Page
CCB-050.....	117
CCB-075.....	117
CCB-100.....	117
CCB-125.....	117
CCB-150.....	117
CCB-200.....	117
CD.....	111
CE.....	111
CH.....	111
CO.....	112
CV.....	111
DC.....	114
DO.....	116
DOG-1.....	119
EM.....	112
EM-CC.....	115
FB.....	118
FC.....	100
FL.....	113
FS.....	113
FT.....	100
HS.....	113
HV.....	113
IB.....	118
JP-06.....	113
JP-09.....	113
JP-12.....	113
JP-120.....	113
JP-18.....	113
JP-24.....	113
JP-30.....	113
JP-36.....	113
LH.....	106
LY.....	107
NF.....	113
NL.....	113
OB.....	118
OT.....	110
P200.....	121
PC.....	115
PF.....	113
PGV120000.....	121
PGV380000.....	121
PH.....	113
PS.....	113
PV.....	113
PVC-PAD.....	119
RC.....	111

Index

Trof - Part Number Index

Part Number	Page
RH	106
RY	107
SL	97
SB	118
SR	110
SS89042	117
ST	105
T200E	122
T201E	122
TC	103-104
TT	101-102
VC	114
VT	110

Trof - Keyword Index

Description	Page
Slotted Rungs	98
30° Horizontal Elbow	99
30° Vertical Elbow Inside	109
30° Vertical Elbow Outside	109
45° Horizontal Elbow	99
45° Vertical Elbow Inside	109
45° Vertical Elbow Outside	109
45° Y Branch Left	107
45° Y Branch Right	107
60° Horizontal Elbow	98
60° Vertical Elbow Inside	108
60° Vertical Elbow Outside	108
90° Angle Connector	111
90° Horizontal Elbow	98
90° Vertical Cable Support Elbow	110
90° Vertical Elbow Inside	108
90° Vertical Elbow Outside	108
Accessories	116-117, 119
Adjustable Elbow	107
Aluminum Tray	86-87
Barrier Strip - Horizontal Fitting	118
Barrier Strip Clamp	119
Barrier Strip Vertical Elbow Inside	118
Barrier Strip Vertical Elbow Outside	118
Barrier Strips	118
Blind End	116
Bonding Jumper	117
Box Connector	116
Cable Tray Ground Clamp	116
Conduit Clamp Brackets	117
Connector Hardware Bolt	112
Connector Plates	111
Cover Accessories	114-115
Cover Connector	115
Cover Screws	112

Description	Page
Covers	113
CSA Ordering Information	94-96
Double Clamp Connector	114
Drop Out	116
Electrical Grounding & Supports	122-123
Electrical Grounding Chart	123
Elevated Cover Connector	115
Expansion Connector	111
Flanged Louvered Cover	113
Flanged Solid Cover	113
Flat Louvered Cover	113
Flat Solid Cover	113
Ground Cable Retainer Clamp	116
Hardware	112
Hat Solid Cover	113
Hat Vent Cover	113
Hold-Down Clamp	119
Horizontal Adjustable Connector	111
Horizontal Cross	100
Horizontal Tapped Cross	103-104
Horizontal Tapped Tee	101-102
Horizontal Tee	100
Isolation Pad	119
Joint Plate	113
Left Hand Reducer	106
Nylon Carrier Splice & Protector	118
Nylon Dropout Grommet	119
Overview	90-91
Part Numbering System	92-93
Peak Cover Connector	115
Peak Vent Cover Connector	114
Peaked Flanged Solid Cover	113
Peaked Hat Solid Cover	113
Peaked Hat Vent Cover	113
Peaked Solid Cover	113
Reducing Connectors	112
Right Hand Reducer	106
Seismic Hold-Down	119
Single Rod Hanger Support	121
Single Side Connector	114
Steel Tray	88-89
Stepdown Connector	111
Straight Length	97
Straight Reducer	105
Structural Support Bracket	120
Support Brackets	120
Trapeze Hanger Support	122
Tray Hanger & Supports	121
Universal Aluminum Barrier Strip - Straight Section	118
Universal Curvilinear Connector	111
Vertical Adjustable Connector	111
Vertical Support	121



Index

Trof - Keyword Index

Description	Page
Vertical Tee Down	110
Vertical Tee Up	110
Wall Penetrating Sleeve Assembly	117
Wall Support Bracket.....	120

FEATURES

SWAGE

I-BEAM

TROF

EAGLE BASKET

CHANNEL

GLAS

AICKINSTRUT

DATA



Index

Eagle Basket - Part Number Index

Part Number	Page
EGL2-02SL-120	129, 132
EGL4-04SL-120	129, 133
EGL6-06SL-120	129, 134
EGL2-04SL-120	129, 132
EGL4-06SL-120	129, 133
EGL6-08SL-120	129, 134
EGL2-06SL-120	129, 132
EGL4-08SL-120	129, 133
EGL6-12SL-120	129, 134
EGL2-08SL-120	129, 132
EGL4-12SL-120	129, 133
EGL6-16SL-120	129, 134
EGL2-12SL-120	129, 132
EGL4-16SL-120	129, 133
EGL6-18SL-120	129, 134
EGL2-16SL-120	129, 132
EGL4-18SL-120	129, 133
EGL6-20SL-120	129, 134
EGL2-18SL-120	129, 132
EGL4-20SL-120	129, 133
EGL6-24SL-120	129, 134
EGL2-20SL-120	129, 132
EGL4-24SL-120	129, 133
EGL2-24SL-120.....	129, 132
T-BAR.....	135
T-BAR-22.....	135
CH1.....	136
CH2.....	136
CH3.....	137
EG-CBN.....	137
BOTTOM-CLIP	137
EGL-CC	138
SPLIT-BOLT.....	138
CBJ-C.....	138
EGL-CVR-(WW)	139
EGL-LINER-(WW).....	139
EGL(H)-01SB-120.....	139
EGL2-01SB-120	139
EGL4-01SB-120	139
EGL6-01SB-120	139
EGL-SIDE-DRC	140
EGL-1x6-DRC	140
EGL-2x8-DRC	140
EGL-HGR-2.....	141
EGL-HGR-4	141
EGL-HGR-6	141
EGL-MSB-(WW).....	142

Part Number	Page
EGL-HSB-(WW).....	142
EGL-MSB-14.....	142
EGL-MSB-08.....	142
EGL-MSB-18.....	142
EGL-MSB-12.....	142
EGL-MSB-22	142
EGL-MSB-16.....	142
EGL-MSB-24	142
EGL-MSB-18.....	142
EGL-MSB-26	142
EGL-MSB-20.....	142
EGL-MSB-30.....	142
EGL-MSB-24.....	142
EGL-MWSB-(WW)	143
EGL-HWSB-(WW).....	141
EGL-HSB-14	142
EGL-HSB-08.....	142
EGL-HSB-18	142
EGL-HSB-12.....	142
EGL-HSB-22.....	142
EGL-HSB-16	142
EGL-HSB-24.....	142
EGL-HSB-18	142
EGL-HSB-26.....	142
EGL-HSB-20	142
EGL-HSB-30	142
EGL-HSB-24.....	142
EGL-ZBAR-04	145
EGL-ZBAR-06	145
EGL-ZBAR-08	145
EGL-ZBAR-12.....	145
EGL-ZBAR-16.....	145
EGL-ZBAR-18.....	145
EGL-ZBAR-20.....	145
EGL-ZBAR-24	145
EGL-MWSB-06.....	143
EGL-MWSB-08.....	143
EGL-MWSB-12	143
EGL-HWSB-08	143
EGL-HWSB-12.....	143
EGL-HWSB-16.....	143
EGL-HWSB-18.....	143
EGL-HWSB-20.....	143
EGL-HWSB-24.....	143
EGL-WC-2	144
EGL-CCA-(WW).....	144
GL-CPA-(WW).....	144



Index

Eagle Basket - Part Number Index Cont.

Part Number	Page
EGL-CCA-04	144
EGL-CCA-06	144
EGL-CCA-08	144
EGL-CCA-12.....	144
EGL-CCA-16	144
EGL-CPA-06	144
EGL-CPA-08	144
EGL-CPA-12	144
EGL-CPA-16	144
EGL-FLR-SPRT-(HH)	145
EGL-ZBAR-(WW).....	145
EGL-PED-06	146
EGL-PED-12.....	146
EGL-PED-KIT	146
EGL-UNI-DO	147
EGL-(WW)DO	147
EGL-(WW)SDO	147
EGL-(WW)TDO	147
EGL-(WW)TBR	148
EGL-(WW)XBR	148
EGL(H)-RADIUS	148
EGL(H)-(WW)BE	149
EGL(H)-(WW)CB	149
CAT(H)-(WW)WS.....	149
EGL-VERT-KIT	150
EGL-EMT CLIP	150

Eagle Basket - Keyword Index

Description	Page
12" Pedestal Bracket	146
2" Basket Hanger	141
2" Load Depth.....	132
22" T-Bar	135
4" Basket Hanger	141
4" Load Depth.....	133
4"-6" Center-Drop Rod Clip.....	140
44" T-Bar.....	135
6" Basket Hanger	141
6" Load Depth.....	134
6" Pedestal Bracket.....	146
8"-12" Center-Drop Rod Clip	140
90° Long Radius Bends	153
90° Short Radius Bends.....	152
Accessories	147-150
Blind End.....	149
Box Connector	149
Brackets.....	144
Ceiling Clip	144
Conduit to Basket Clip.....	150

Description	Page
Covers.....	139
Cross Bridge.....	148
Cutting Tool	151
Dividers.....	139
Dropouts.....	147
Elevation Change Kit	150
Finishes.....	131
Fitting Hardware	136-137
Fitting Splices	135
Fittings Assembly	151-155
Fittings Overview	151-155
Floor Support.....	145
Ground and Underfloor Supports.....	145
Grounding.....	138
Grounding Clip.....	138
Grounding Wire Split Bolt.....	138
Heavy-Duty Support Bracket	142
Heavy-Duty Support Wall Bracket	143
Left Reducer	155
Liners	139
Materials.....	131
Medium Support Bracket.....	142
Medium Support Wall Bracket	143
Mounting Hangers.....	141
Mounting Rod Clips.....	140
Mounting Supports.....	142
Over-The-Top Dropout	147
Pedestal Brackets	146
Pedestal Kit.....	146
Product Code.....	131
QUICK-LATCH [™]	130
Radius Shield.....	148
Reducers	155
Right Reducer.....	155
Riser	155
Riser Fittings.....	155
Side Dropout	147
Side-Drop Rod Clip.....	140
Standard Cross	154
Standard Tee	154
Straight Reducer.....	155
Tee Bridge.....	148
Universal Dropout.....	147
Wall Bracket	144
Wall Brackets.....	143
Wall Clip.....	144
Wall Sleeve	149
Waterfall Dropout.....	147
Zed Brackets.....	145

Index

Channel - Part Number

Part Number	Page
30H	161
30VI	161
30VO	161
45H	161
45VI	161
45VO	161
60H	161
60VI	161
60VO	161
90H	161
90VI	161
90VO	161
ACHD-A-03	165
ACHD-A-04	165
ACHD-A-06	165
ACHS-A-03-04	164
ACHS-A-06	164
BE-AC3-(F)*	165
BE-AC4-(F)*	165
BE-AC6-(F)*	165
CFB-AC3-(F)*	165
CFB-AC4-(F)*	165
CFB-AC6-(F)*	165
CFS-AC-03-S	164
CFS-AC-04-S	164
CFS-AC-06-S	164
CMB-AC3-(F)*	165
CMB-AC4-(F)*	165
CMB-AC6-(F)*	165
CTC	163
DVS-(L)*	162
DVS-5	162
FFS	164
FFV	164
HC	161
HDC-AC	164
HDE-AC	165
HDZ-AC	165
HT	161
SL	160
SPB	163
SPE	163
SPH	163
SPR-AC43-(F)*4	163
SPR-AC63-(F)*4	163
SPR-AC64-(F)*4	163
SPV	163
SPW	163
WBC-A-08	165
WBC-A-10	165

WBSC-A-08	165
WBSC-A-10	165

Channel - Keyword Index

Description	Page
30° Horizontal Fitting	161
30° Inside Vertical Fitting	161
30° Outside Vertical Fitting	161
45° Horizontal Fitting	161
45° Inside Vertical Fitting	161
45° Outside Vertical Fitting	161
60° Horizontal Fitting	161
60° Inside Vertical Fitting	161
60° Outside Vertical Fitting	161
90° Horizontal Fitting	161
90° Inside Vertical Fitting	161
90° Outside Vertical Fitting	161
Blind End	165
Box Connector	163
Cable Bushing	158
Cable Channel Straight Aluminum	158
Channel Connectors	163
Channel Covers	164
Channel Dividers	162
Channel Splices	163
Channel-to-Channel	163
Combo Cover Clamp & Hold Down	164
Cover Clamps	164
Cross Horizontal Fitting	161
Divider Splice	162
Double Hanger	165
Expansion	163
Fittings	161
Flat Covers	164
Flat Flanged Solid Cover	164
Flat Flanged Ventilated Cover	164
Floor Base Plate	165
Horizontal Adjustable	163
Horizontal Fittings	161
Horizontal Flexible Divider	162
Mounting Bracket	165
Reducing Splices	163
Single Hanger	164
Standard	163
Straight Divider	162
Strut Bracket	165
Support Clamps	165
Tee Horizontal Fitting	161
Tray-to-Channel	163
Vertical Adjustable	163
Vertical Elbow Divider	162



Index

Channel - Keyword Index

Description	Page
Vertical Fittings.....	161
Wall Bracket	164-165

Cope-Glas[™] - Part Number Index

Number	Page
252075.....	212
500PU-200.....	205
ADC1.....	206
BE.....	189
BE060610.....	189
BE060620.....	189
BE060910.....	189
BE060920.....	189
BE061210.....	189
BE061220.....	189
BE090610.....	189
BE090620.....	189
BE090910.....	189
BE090920.....	189
BE091210.....	189
BE091220.....	189
BE120610.....	189
BE120620.....	189
BE120910.....	189
BE120920.....	189
BE121210.....	189
BE121220.....	189
BE180610.....	189
BE180620.....	189
BE180910.....	189
BE180920.....	189
BE181210.....	189
BE181220.....	189
BE240610.....	189
BE240620.....	189
BE240910.....	189
BE240920.....	189
BE241210.....	189
BE241220.....	189
BE300610.....	189
BE300620.....	189
BE300910.....	189
BE300920.....	189
BE301210.....	189
BE301220.....	189
BE360610.....	189
BE360620.....	189
BE360910.....	189
BE360920.....	189
BE361210.....	189

Part Number	Page
BE361220.....	189
C.....	210
C2-SL10.....	209
C3-SL10.....	209
C4-SL10.....	209
C6-SL10.....	209
C8-SL10.....	209
CC1.....	205
CCE.....	205
CE.....	190
CE060610.....	190
CE060620.....	190
CE060910.....	190
CE060920.....	190
CE061210.....	190
CE061220.....	190
CE061810.....	190
CE061820.....	190
CE090610.....	190
CE090620.....	190
CE090910.....	190
CE090920.....	190
CE091210.....	190
CE091220.....	190
CE091810.....	190
CE091820.....	190
CE120610.....	190
CE120620.....	190
CE120910.....	190
CE120920.....	190
CE121210.....	190
CE121220.....	190
CE121810.....	190
CE121820.....	190
CE180610.....	190
CE180620.....	190
CE180910.....	190
CE180920.....	190
CE181210.....	190
CE181220.....	190
CE181810.....	190
CE181820.....	190
CE240610.....	190
CE240620.....	190
CE240910.....	190
CE240920.....	190
CE241210.....	190
CE241220.....	190
CE241810.....	190
CE241820.....	190

Index

Cope-Glas™ - Part Number Index Cont.

Part Number	Page
E300610	190
CE300620	190
CE300910	190
CE300920	190
CE301212	190
CE301220	190
CE301810	190
CE301820	190
CE360610	190
CE360620	190
CE360910	190
CE360920	190
CE361212	190
CE361220	190
CE361810	190
CE361820	190
CG-CCB-050	207
CG-CCB-075	207
CG-CCB-100	207
CG-CCB-125	207
CG-CCB-150	207
CG-CCB-200	207
CG-CCB-250	207
CG-CCB-300	207
CG-CCB-400	207
CH	209
CH2-(L)	209
CH3-(L)	209
CH3-(L)P	209
CH4-(L)	209
CH4-(L)P	209
CH6-(L)	209
CH6-(L)P	209
CH8-(L)	209
CH8-(L)P	209
CHSP	212
CHSPH22	212
CHSPH22	212
CHSPH22	212
CHSPH22	212
CHSPH22	212
CHSPH45	212
CHSPH45	212
CHSPH45	212
CHSPH45	212
CHSPH45	212
CHSPH90	212
CHSPH90	212
CHSPH90	212

Part Number	Page
CHSPH90	212
CHSPH90	212
CHSPV22	212
CHSPV22	212
CHSPV22	212
CHSPV22	212
CHSPV22	212
CHSPV45	212
CHSPV45	212
CHSPV45	212
CHSPV45	212
CHSPV45	212
CHSPV45	212
CHSPV90	212
CHSPV90	212
CHSPV90	212
CHSPV90	212
CHSPV90	212
CTB06A	208
CTB09A	208
CTB12A	208
CTB18A	208
CTB24A	208
CTB30A	208
CTB36A	208
CTC06	191
CTC06V	191
CTC09	191
CTC09V	191
CTC12	191
CTC12V	191
CTC18	191
CTC18V	191
CTC24	191
CTC24V	191
CTC30	191
CTC30V	191
CTC36	191
CTCE06	191
CTCE06V	191
CTCE09	191
CTCE09V	191
CTCE12	191
CTCE12V	191
CTCE18	191
CTCE18V	191
CTCE24	191
CTCE24V	191
CTCE30	191
CTCE30V	191



Index

Cope-Glas™ - Part Number Index Cont.

Part Number.....	Page	Part Number.....	Page
CTCE36.....	191	CZD301220.....	190
CTCE36V.....	191	CZD301810.....	190
CTG36V.....	191	CZD301820.....	190
CZD.....	190	CZD360610.....	190
CZD060610.....	190	CZD360620.....	190
CZD060620.....	190	CZD360910.....	190
CZD060910.....	190	CZD360920.....	190
CZD060920.....	190	CZD361212.....	190
CZD061212.....	190	CZD361220.....	190
CZD061220.....	190	CZD361810.....	190
CZD061810.....	190	CZD361820.....	190
CZD061820.....	190	D006.....	207
CZD090610.....	190	D009.....	207
CZD090620.....	190	D012.....	207
CZD090910.....	190	D018.....	207
CZD090920.....	190	D024.....	207
CZD091212.....	190	D030.....	207
CZD091220.....	190	D036.....	207
CZD091810.....	190	EPE06.....	205
CZD091820.....	190	EPE09.....	205
CZD120810.....	190	EPE12.....	205
CZD120820.....	190	EPE18.....	205
CZD120910.....	190	EPE24.....	205
CZD120920.....	190	EPE30.....	205
CZD121212.....	190	EPE36.....	205
CZD121220.....	190	EPL06.....	205
CZD121810.....	190	EPL09.....	205
CZD121820.....	190	EPL12.....	205
CZD180610.....	190	EPL18.....	205
CZD180620.....	190	EPL24.....	205
CZD180910.....	190	EPL30.....	205
CZD180920.....	190	EPL36.....	205
CZD181212.....	190	EPZ06.....	205
CZD181220.....	190	EPZ09.....	205
CZD181810.....	190	EPZ12.....	205
CZD181820.....	190	EPZ18.....	205
CZD240610.....	190	EPZ24.....	205
CZD240620.....	190	EPZ30.....	205
CZD240910.....	190	EPZ36.....	205
CZD240920.....	190	F400.....	206
CZD241212.....	190	FE.....	190
CZD241220.....	190	FE060610.....	190
CZD241810.....	190	FE060620.....	190
CZD241820.....	190	FE060910.....	190
CZD300610.....	190	FE060920.....	190
CZD300620.....	190	FE061212.....	190
CZD300910.....	190	FE061220.....	190
CZD300920.....	190	FE090610.....	190
CZD301212.....	190	FE090620.....	190

Index

Cope-Glas™ - Part Number Index Cont.

Part Number	Page	Part Number	Page
FE090910	190	LC060910	189
FE090920	190	LC060912	189
FE091210	190	LC061210	189
FE091220	190	LC061212	189
FE120610	190	LC090612	189
FE120620	190	LC090910	189
FE120910	190	LC090912	189
FE120920	190	LC091210	189
FE121210	190	LC091212	189
FE121220	190	LC120610	189
FE180610	190	LC120612	189
FE180620	190	LC120910	189
FE180910	190	LC120912	189
FE180920	190	LC121210	189
FE181210	190	LC121212	189
FE181220	190	LC180610	189
FE240610	190	LC180612	189
FE240620	190	LC180910	189
FE240910	190	LC180912	189
FE240920	190	LC181210	189
FE241210	190	LC181212	189
FE241220	190	LC240610	189
FE300610	190	LC240612	189
FE300620	190	LC240910	189
FE300910	190	LC240912	189
FE300920	190	LC241210	189
FE301210	190	LC241212	189
FE301220	190	LC300610	189
FE360610	190	LC300612	189
FE360620	190	LC300910	189
FE360910	190	LC300912	189
FE360920	190	LC301210	189
FE361210	190	LC301212	189
FE361220	190	LC360610	189
FECNBSS	205	LC360612	189
H12	204	LC360910	189
H45	197	LC360912	189
H90	197	LC361210	189
HAB	198	LC361212	189
HB	210	LF400	206
HD4AB	206	LH12	204
HDBLTNT	206	LV12	204
HT	211	LV22.5	204
LADC1	206	LV45	204
LC	189	LV90	204
LC060610	189	MONBW2	205
LC090610	189	NDR1	205
LC060612	189	PTK06	191



Index

Cope-Glas[™] - Part Number Index Cont.

Part Number	Page
PTK09	191
PTK12	191
PTK18	191
PTK24	191
PTK30	191
PTK36	191
PTKE06	191
PTKE09	191
PTKE12	191
PTKE18	191
PTKE24	191
PTKE30	191
PTKE36	191
RGBS4V	206
RGFH1	207
RGFH2	207
RL	200
RR	200
RS	200
SBNBW2	205
SPH	212
SPV	212
SSNBW2-316	205
T	199
V12	204
V22.5	204
V45	204
V45I	194
V45O	194
V90	204
V90I	193
V90O	193
VAB	195
VI	211
VO	211
VT	196
X	202, 211

Cope-Glas[™] - Keyword Index

Part Number	Page
0° thru 90° Vertical Adjustable Elbows	195
45° Horizontal Elbows	197
45° Vertical Inside Elbows	194
45° Vertical Outside Elbows	194
90° Horizontal Elbows	197
90° Vertical Inside Elbows	193
90° Vertical Outside Elbows	193
Accessories	207

Adjustable Divider Clamp	206
Adjustable Horizontal Splice Plates	204
Adjustable Vertical Splice Plates	204
Advantages of COPE-GLAS [™] Cable Tray	171
Application Environments	178-179
Barrier Strip	206
Cable Tray Hardware	205
Channel Fittings	209
Channel Splice Plate Hardware	212
Channel Splice Plates	212
Conduit to Cable Tray Clamp	207
Construction and Physical Properties	176-177
COPE-GLAS Cable Tray Covers	191
Cover Clamp	205
Cover Stand-Offs	207
Covers	191
Drop Outs	207
End Plates	205
Expansion Splice Plates	203
Fiberfast Bolts	205
Fiberglass Bolt	205
Fiberglass Channel	209-212
Fitting Covers	210
Fittings	192-202
Fixed Angle Horizontal Splice Plates	203
Fixed Angle Vertical Splice Plates	204
Flat Cover	191
Floor & Panel Flange	206
Hold Down Package	206
Horizontal Adjustable Elbows	198
Horizontal Cross	202, 211
Horizontal Elbow Splice Plates	212
Horizontal Elbows	210
Horizontal Tee	211
Horizontal Tees	199
Inside Vertical Elbow	211
Installation Procedures	182-188
Left Reducers	200
Marine Rung	208
Outside Vertical Elbow	211
Peaked Cover	191
Right Reducers	200
Rivet	205
Selection Guide	181
Specifications	175
Standards	173-174
Straight Covers	210
Straight Reducers	200

Index

Cope-Glas™ - Keyword Index

Part Number	Page
Straight Sections	189
Straight Splice Plates.....	203
Straight Splice Plates.....	212
Structural Designs.....	180
Tray Covers and Accessories	205-206
Tray Flange Hanger	207
Type BE Straight Section - E Profile	189
Type CE Straight Section - E Profile.....	190
Type CZD Straight Section - Deep Z Profile	190
Type FE Straight Section - Z Profile.....	190
Type LC Straight Section - C Profile	189
Vertical Elbow Splice Plates	212
Vertical Tees	196
Wall Support Brackets	208

Aickin strut - Part Number Index

Part Number	Page
1000E-999	244
1000PU-000	243
1000PU-FN-000	243
1000V-000.....	244
100-1500	247
100-1501	247
100-1502	247
100-1503	247
100-1504	247
100-1505	247
100-1506	247
100-1507.....	247
100-1508.....	247
100-1509	247
100-1510.....	247
100-1511.....	247
100-1512	247
100-1513	247
100-1514	247
10PU-CN.....	245
10PU-CNMHD	245
10PU-CNS.....	245
12PU-CN.....	245
12PU-CNMHD.....	245
16PU-CNMHD	245
18X-10234-20	253
18X-1100-20	252
18X-1110-20	252
18X-111214-20	254
18X-1120-20.....	252
18X-11211214-20	254

Part Number	Page
18X-1130-20.....	252
18X-1200-20	252
18X-1300-20	252
18X-1310-20	252
18X-1320-20.....	252
18X-1400-20	252
18X-1410-20.....	252
18X-1420-20.....	252
18X-1500-20	252
18X-1510-20.....	252
18X-2100-20	252
18X-2110-20	252
18X-211214-20	254
18X-2120-20.....	253
18X-2130-20.....	252
18X-2140-20.....	253
18X-2160-20	252
18X-2170-20.....	253
18X-2180-20	252
18X-2190-25.....	253
18X-2200-20	253
18X-2210-25.....	252
18X-2220-25	253
18X-2230-20.....	252
18X-2240-20.....	252
18X-2300-20	252
18X-2400-20	252
18X-2500-20	253
18X-2600-20.....	252
18X-2700-20.....	253
18X-2800-20	252
18X-2900-20	253
18X-2916-20.....	253
18X-3078-20	253
18X-3100-20	254
18X-3110-20	254
18X-3111-20.....	254
18X-3112-20.....	253
18X-3114-20.....	253
18X-3120-20.....	254
18X-3121-20.....	254
18X-31316-20	253
18X-3140-20.....	254
18X-3200-20	254
18X-3300-20	254
18X-3310-20.....	254
18X-3400-20	254
18X-3410-20.....	254
18X-3500-20	254



Index

Aickinstrut - Part Number Index

Part Number.....	Page
18X-3510-20.....	254
18X-3600-20.....	254
18X-3610-20.....	254
18X-3800-20.....	254
18X-3810-20.....	254
18X-3900-20.....	254
18X-4100.....	253
18X-4118-20.....	253
18X-4118-20.....	254
18X-412138-20.....	254
18X-4138-20.....	253
18X-418214-20.....	254
18X-4200.....	253
18X-4300.....	253
18X-438138-20.....	254
18X-4400.....	253
18X-4500.....	253
18X-4600.....	253
18X-4700.....	253
18X-4800.....	253
18X-5100-20.....	253
18X-5125-20.....	253
18X-5150-20.....	253
18X-518218-20.....	254
18X-5200-20.....	253
18X-5218-20.....	254
18X-61116-20.....	253
18X-612212-20.....	254
18X-6158-20.....	253
18X-6414-20.....	254
18X-70012-20.....	255
18X-7001316-20.....	255
18X-70014-20.....	255
18X-70018-20.....	255
18X-700316-20.....	255
18X-70034-20.....	255
18X-70035-20.....	255
18X-70038-20.....	255
18X-700516-20.....	255
18X-70058-20.....	255
18X-70100-20.....	255
18X-70112-20.....	255
18X-70114-20.....	255
18X-70200-20.....	255
18X-70212-20.....	255
18X-70300-20.....	255
18X-7100-20.....	255
18X-711214-20.....	255
18X-711218-20.....	255

Part Number.....	Page
18X-711414-20.....	255
18X-711418-20.....	255
18X-7114332-20.....	255
18X-7118-20.....	255
18X-713414-20.....	255
18X-713418-20.....	255
18X-7214-20.....	255
18X-7300-20.....	255
18X-7312-20.....	255
18X-7314-20.....	255
18X-7418-20.....	255
18X-74316-20.....	255
18X-82316-20.....	253
200-3100.....	237
200-3110.....	237
200-3120.....	237
200-3130.....	237
200-3140.....	237
200-3827.....	249
200-3828.....	249
200-3829.....	249
200-3830.....	249
200-3831.....	249
200-3840.....	249
200-3841.....	249
200-3842.....	249
200-3843.....	249
200-4217.....	245
200-4219.....	246
200-4226.....	245
200-4227.....	246
200-4341.....	245
200-4342.....	245
200-4343.....	246
20E-1000.....	227
20E-1200.....	227
20E-2000.....	226
20E-2200.....	226
20E-2300.....	226
20E-5000.....	241
20N-ARM08.....	250
20N-ARM14.....	250
20N-ARM17.....	250
20N-ARM23.....	250
20N-STA21.....	250
20N-STA33.....	250
20P-1000.....	227
20P-1100.....	227
20P-1200.....	227

Index

Aickinstrut - Part Number Index

Part Number	Page
20P-1300	227
20P-1500	226
20P-1600	226 231
20P-1700	226
20P-2000	226
20P-2000-SST	227
20P-2100	226
20P-2100-SST	227
20P-2200	226
20P-2200-SST	227
20P-2300	226
20P-2300-SST	227
20P-2500	232
20P-2502	232
20P-2504	232
20P-2506	232
20P-2508	233
20P-2510	233
20P-2512	233
20P-2514	233
20P-2516	233
20P-2518	233
20P-2520	233
20P-2522	234
20P-2524	234
20P-2526	234
20P-2528	234
20P-2530	234
20P-2534	234
20P-2540	235
20P-2541	235
20P-2542	235
20P-2800	232
20P-2802	232
20P-2804	232
20P-2806	232
20P-2808	233
20P-2810L	233
20P-2810R	233
20P-2812	233
20P-2814	233
20P-2816L	233
20P-2816R	233
20P-2818	233
20P-2820	233
20P-2822	234
20P-2824	234
20P-2826	234
20P-2828	234
20P-2830	234

Part Number	Page
20P-2834	234
20P-2840	235
20PP-5853	236
20PP-5854	236
20PP-5855	236
20PP-5903	236
20PP-5904	236
20PP-5905	236
20PU-5852	251
20PU-5852 RD	251
20PU-5853	236
20PU-5853	251
20PU-5853 HD	251
20PU-5854	236
20PU-5854 HD	251
20PU-5855	236
20PU-5903	236
20PU-5904	236
20PU-5905	236
20PU-CNMHD	245
20V-1000	227
20V-1100	227
20V-1200	227
20V-1300	227
20V-1500	226
20V-1600	226, 231
20V-1700	226
20V-2000	226
20V-2000-SST	227
20V-2100	226
20V-2100-SST	227
20V-2200	226
20V-2200-SST	227
20V-2300	226
20V-2300-SST	227
20V-2500	232
20V-2502	232
20V-2504	232
20V-2506	232
20V-2508	233
20V-2510	233
20V-2512	233
20V-2514	233
20V-2516	233
20V-2518	233
20V-2520	233
20V-2522	234
20V-2524	234
20V-2526	234
20V-2528	235



Index

Aickinstrut - Part Number Index

Part Number.....	Page	Part Number.....	Page
20V-2530	235	375PU-CNHD	245
20V-2534	235	375PU-FN-000	243
20V-2540	235	375V-000	244
20V-2541	235	375V-100	243
20V-2542	235	375V-125	243
20V-2800	232	375V-150	243
20V-2802	232	375V-175	243
20V-2804	232	375V-200	243
20V-2806	232	375V-250	243
20V-2808	233	375V-300	243
20V-2810L	233	375V-350	243
20V-2810R	233	375V-400	243
20V-2812	233	500E-999	244
20V-2814	233	500PU-000	243
20V-2816L	233	500PU-125	242
20V-2816R	233	500PU-150	242
20V-2818	233	500PU-200	242
20V-2820	233	500PU-250	242
20V-2822	234	500PU-300	242
20V-2824	234	500PU-350	242
20V-2826	234	500PU-BC	248
20V-2828	234	500PU-CN	245
20V-2830	234	500PU-CNHD	245
20V-2834	234	500PU-FN-000	243
20V-2840	235	500V-000	244
20V-2BC-25	248	50PU-1508	236
20V-2BC-37	248	50PU-2008	236
20V-2BC-50	248	50PU-2045	236
250E-999	244	50PU-2090	236
250PU-000	243	50PU-2538	236
250PU-075	242	50PU-2611	245
250PU-100	242	50PU-2611-SP	245
250PU-150	242	50PU-2613	245
250PU-CN	245	50PU-2616	243
312E-999	244	50PU-26361	236
312PU-000	243	50PU-2636A2	236
312PU-100	242	50PU-2636B3	236
312PU-125	242	50PU-29364	236
312PU-200	242	50PU-500SP	241
312PU-CN	245	625E-999	244
375E-999	244	625PU-000	243
375PU-000	243	625PU-125	242
375PU-125	242	625PU-150	242
375PU-150	242	625PU-200	242
375PU-200	242	625PU-250	242
375PU-250	242	625PU-300	242
375PU-300	242	625PU-350	242
375PU-BC	248	625PU-CNHD	245
375PU-BCCLP	248	625PU-FN-000	243
375PU-CN	245	625V-000	244

Index

Aickinstrut - Part Number Index

Part Number.....	Page
750E-999	244
750PU-000	243
750PU-CNHD.....	245
750PU-FN-000	243
750V-000	244
AIC-CH-P	249
AIC-CH-V	249
AIC-EC.....	241
CTB06A	251
CTB09A	251
CTB12A.....	251
CTB18A.....	251
CTB24A.....	251
CTB30A	251
CTB36A.....	251
CVHPU-100	245
CVHPU-150.....	245
CVHPU-200.....	245
CVHPU-400.....	245
CVHPU-600	245
PCR-050	238
PCR-075.....	238
PCR-100	238
PCR-125.....	238
PCR-150.....	238
PCR-200	238
PCR-250.....	238
PCR-300	238
PCR-400	238
PCR-600.....	238
PCR-800	238
PS050	239
PS075.....	239
PS100	239
PS1000.....	239
PS1200	239
PS1400	239
PS150	239
PS1600.....	239
PS1800	239
PS200	239
PS250	239
PS300	239
PS350	239
PS400	239
PS500.....	239
PS600.....	239
PS800.....	239

Part Number.....	Page
RGBC1	248
RGBC2.....	248
RGBC3.....	248
UB-050	240
UB-075	240
UB-100	240
UB-125	240
UB-150.....	240
UB-200.....	240
UB-250.....	240
UB-300.....	240
UB-350	240
UB-400	240
UB-600	240
WR375	244
WR375SQ.....	244
WR500	244
WR500SQ	244
WR625.....	244
WR625SQ	244
WR750.....	244
WR750SQ	244



Index

Aickinstrut - Keyword Index

Description	Page
Adjustable Pipe Clamps.....	237
Aickinclamp Design Load Information	237
AICKINSHAPE® Structural Shapes.....	252
Aickinstrut SST Channel	225
A-Konnector Rod Couplers	249
All-Thread Washers	244
Back-to-Back Heavy Duty Channel	226-227
Back-to-Back Medium Duty Channel	226-227
Beam Clamps	248
Beam Clip.....	248
Beam Loading	228
Channel.....	253
Channel Availability Chart	224
Channel Capping Strip	241
Channel End Cap.....	241
Channel Fittings	232-236
Channel Framing	224
Channel Hangers	249
Channel Loading.....	228-231, 237
Channel Nuts.....	245
Channel Spacers	241
Clevis Hangers	247
Column Loading.....	228
Concrete Embedment Channel	225
Contents.....	214
Embedment Angle	254
Equal Leg Angle.....	252
Fabricated Beam Clamps	248
Fasteners.....	242-246
Fiberfast Bolts	242
Fiberfast Hex Nuts.....	243
Flange Loading	229
Flat Channel Fittings.....	232-236
Flat Sheet	253
Flat Washers	244
Grooved Channel Fittings.....	232-236
Hand Lay-Up Clevis Hangers.....	247
Heavy Duty Channel	226
Heavy Duty Channel Nuts	245
Heavy Duty Channel with.....	226-227
Concrete Inserts.....	226-227
Heavy Duty Post Base	251
Hex Bolts.....	242
Hex Flange Bolts.....	242
Hex Flange Nuts.....	243
Hex Nuts.....	243
I-Beam	252

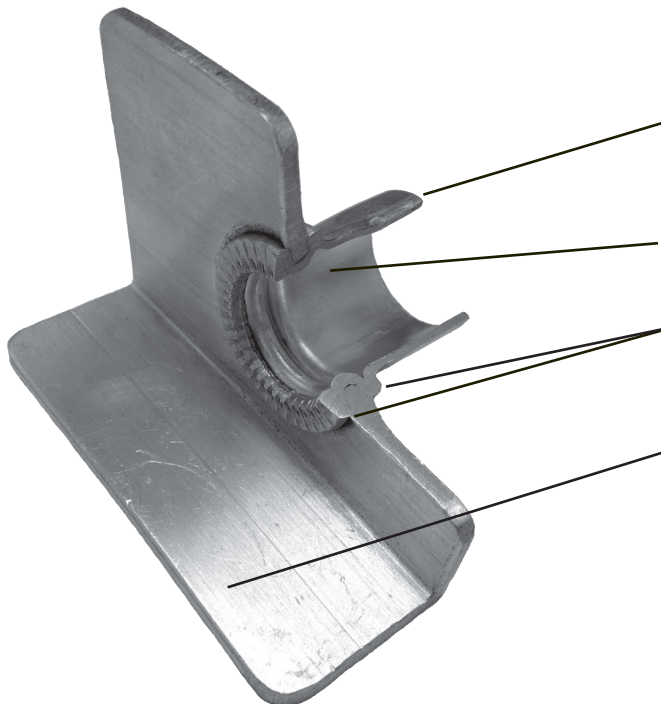
Description	Page
Instrument Stands	251
Introduction	215
Medium Duty Channel	226-227
Medium Duty Channel with	226-227
Concrete Inserts.....	226-227
Molded Beam Clamps.....	248
Molded Clevis Hangers.....	247
Nonmetallic U-bolts	240
Pipe Clamps.....	238-241
Pipe Hangers.....	247-248
Pipe Shape	252-255
Pipe Stands	251
Pipe Supports.....	249-251
Power-Rack Stanchions	250
PVC Beam Load.....	228
Rectangular Tube	254
Round Rod	255
Round Tube	255
Saddle Clips	245
Section Properties.....	229
Slotted Heavy Duty Channel.....	226
Slotted Medium Duty Channel.....	226-227
Specifications.....	220-225
Square Bar	253
Square Tube.....	254
Standard Duty Channel Nuts	245
Standard Heavy Duty Channel.....	226
Standard Medium Duty Channel.....	226-227
Stop-Lock Assemblies.....	246
Technical Information	216-219
Threaded Rod.....	249
Type 1 Design Load	237
Type 2 Design Load	237
Cope-Glas Beam Clamps.....	248
Vinyl Ester Square Head Bolts	243
Vinyl Ester Square Nuts	244
Wall Brackets.....	251
Wide Flange I-Beam	253

Index

Cope® uses a unique manufacturing process called “cold swaging” to attach rung to rail. Compared to welded products, Cope cold LADDERd cable tray offers double the pull out strength, provide stiffer overall rigidity, freer access to cables and look better installed. This unique manufacturing process is extremely efficient which quickens production and improves product availability.

Application Spotlight: Wind Turbines Renewable Energy is a growing and important segment to the energy industry. The wind power industry is developing into an important player in that mix. Cope cold LADDERd cable tray has proven to be a vital component in the construction of the thousands of wind towers that have been built in recent years.

Wind turbines vibrate intensely during operation. This can cause welded tray to become brittle and snap after a relatively short period of time. Cope cold LADDERd tray has proven durable even in this extreme dynamic state environment. This reliable performance under extreme conditions is the basis for prominent manufacturers incorporating Cope products into their wind tower designs.



- Flat profile formed during crimp process provides uniform cable bearing surface
- Weldless, mechanical connection made at 200,000 lbs
- Double ring crimp profile provides strength and rigidity in high load applications
- High quality T6063-T6 grade aluminum

Atkore - COPE

This product specification is written according to the Construction Specifications Institute *MasterFormat*, 2018 Update.

SECTION 26 05 36

CABLE TRAYS FOR ELECTRICAL SYSTEMS (Ladder Tray)

PART 1 GENERAL

1.1 SUMMARY

- A. The work covered under this Section 26 05 36 consists of furnishing of necessary labor, supervision, materials, equipment, tests and services to install complete cable tray systems as shown on the drawings.
- B. Cable tray systems are defined to include but are not limited to straight sections of [ladder type] [trough type] [solid bottom type] [channel type] cable trays, bends, tees, elbows, drop-outs, supports, and accessories.
- C. Related Sections:
 - 1. Section 26 05 26 - Grounding and Bonding for Electrical Systems.
 - 2. Section 26 05 29 - Hangers and Supports for Electrical Systems

1.2 REFERENCES

- A. ASTM International:
 - 1. ASTM A123/A123M - Standard Specification for Zinc (Hot-Dip Galvanized) Coatings on Iron and Steel Products.
 - 2. ASTM A653/A653M - Standard Specification for Steel Sheet, Zinc-Coated (Galvanized) or Zinc-Iron Alloy-Coated (Galvannealed) by the Hot-Dip Process.
 - 3. ASTM A1011 – Specification for Steel, Sheet and Strip, Hot-Rolled, Carbon, Structural, High-Strength Low-Alloy and High Strength Low Alloy with Improved Formability (*Formally ASTM A570 & A607*).
 - 4. ASTM A1008 – Specification for Steel, Sheet, Cold-Rolled, Carbon, Structural, high-Strength Low-Alloy and high-Strength Low-Alloy with Improved Formability (*Formally ASTM A611*).
 - 5. ASTM B633 – Specification for Electrodeposited Coatings of Zinc on Iron and Steel.
- B. National Electrical Manufacturers Association:
 - 1. NEMA VE 1- - Metal Cable Tray Systems.
 - 2. NEMA VE 2- - Cable Tray Installation Guidelines.
- C. NFPA 70: National Electrical Code

1.3 DRAWINGS

- A. The drawings, which constitute a part of these specifications, indicate the general route of the cable tray systems. Data presented on these drawings is as only accurate as preliminary surveys and planning can determine until final equipment selection is made. Accuracy is not guaranteed and field verification of all dimensions, routing, structural loading, regional and national compliances are required.
- B. Specifications and drawings are for assistance and guidance, but exact routing, locations, distances and levels will be governed by actual field conditions. Contractor is directed to make field surveys as part of his work prior to submitting system layout drawings.

1.4 QUALITY ASSURANCE

- A. All cable and equipment shall be installed in a neat and professional manner. All methods of construction that are not specifically described or indicated in the contract documents shall be subject to the control and approval of the owner or owner's representative. Atkore does not warrant and shall not be liable for any claims or damages related to the installation of the products.
- B. Distributors to supply all equipment and accessories new and free from defects.
- C. Distributors to supply all equipment and accessories in compliance with the applicable standards listed in Part 1.2 of this section and with all applicable national, state and local codes.
- D. Distributors to supply all items of a given type shall be the products of the same manufacturer.
- E. Manufacturers: Firms regularly engaged in manufacture of cable trays and fittings of types and capacities required, whose products have been in satisfactory use in similar service for not less than 5 years.
- F. NEMA Compliance: Manufacturer to comply with NEMA Standards Publication Number VE1, "Cable Tray Systems".
- G. NEC Compliance: Contractor to comply with NEC, as applicable to construction and installation of cable tray and cable channel systems (Article 392 NEC).
- H. UL Compliance: Manufacturer to provide products that are UL-classified and labeled.
- I. NFPA Compliance: Contractor to comply with NFPA 70B, "Recommended Practice for Electrical Equipment Maintenance" pertaining to installation of cable tray systems.

1.5 DELIVERY, STORAGE AND HANDLING

- A. Onsite delivery of cable tray systems and components carefully to avoid breakage, denting and scoring finishes. Do not install damaged equipment.
- B. Onsite storage of cable trays and accessories to be in in original cartons and in clean dry space; protect from weather and construction traffic. Wet materials should be unpacked and dried before storage.

1.6 SUBMITTALS

- A. Section 01 33 00 - Submittal Procedures: Submittal procedures.
- B. Shop Drawings: Indicate tray type, dimensions, support points, and finishes.
- C. Product Data: Submit fittings and accessories.
- D. Manufacturer's Installation Instructions: Submit application conditions and limitations of use stipulated by Product testing agency specified under Regulatory Requirements. Include instructions for storage, handling, protection, examination, preparation, and installation of Product.

1.7 CLOSEOUT SUBMITTALS

- A. Section 01 70 00 - Execution and Closeout Requirements: Closeout procedures.
- B. Project Record Documents: Contractor to record actual routing of cable tray and locations of supports.

1.8 QUALIFICATIONS

- A. Manufacturer: Company specializing in manufacturing Products specified in this section with minimum [] years of documented experience, and with service facilities within [] miles of Project.

1.9 PRE-INSTALLATION MEETINGS

- A. Section 01 30 00 - Administrative Requirements: Pre-installation meeting.
- B. Convene a minimum of [] week(s) prior to commencing work of this section.

PART 2 PRODUCTS

1.1 NEMA VE 1 Class designation, indicated in the following specifications for metal cable tray, is support span in feet (meters) plus working load designation.

A. Available Support Spans: 8, 10, 12, 16, and 20 feet (2440, 3048, 3660, 4870, and 6090 mm).

- B. Working Load Designation:
- A - 50 pounds per foot (74.4 kg/m).
 - B - 75 pounds per foot (111.6 kg/m).
 - C - 100 pounds per foot (148.8 kg/m).

C. For example, Class 20C applies to cable tray required to span 20 feet (6090 mm) between supports while supporting cable static weight between 75 and 100 pounds per foot (111.6 and 148.8 kg/m).

D. Consult NEMA VE 1 for additional information and safety factors.

2.1 ACCEPTABLE MANUFACTURERS

A. Subject to compliance with these specifications, wire basket cable tray systems to be installed shall be as manufactured by the following:

1. Atkore – Cope
11500 Norcom Rd
Philadelphia, PA 19154
TOLL-FREE / 800-882-5543

2.2 CABLE TRAY SECTIONS AND COMPONENTS

A. General: Except as otherwise indicated, provide metal cable trays, of types, classes and sizes indicated; with splice plates, bolts, nuts and washers for connecting units. Construct units with rounded edges and smooth surfaces; in compliance with applicable standards.

B. Materials and Finish: Material and finish specifications for each tray type are as follows:

1. Aluminum: Straight section and fitting side rails and rungs shall be extruded from Aluminum Association Alloy 6063. All fabricated parts shall be made from Aluminum Association Alloy 5052.
2. Pre-galvanized Steel: Straight sections, fitting side rails, rungs, and covers shall be made from steel meeting the minimum mechanical properties and mill galvanized in accordance with ASTM A653 SS, Grade 33, coating designation G90.
3. Hot-dip Galvanized Steel: Straight section and fitting side rails and rungs shall be made from steel meeting the minimum mechanical properties of ASTM A1011 SS, Grade 33 for 14 gauge and heavier, ASTM A1008, Grade 33, Type 2 for 16 gauge and lighter, and shall be hot-dip galvanized after fabrication in accordance with ASTM A123. All covers and splice plates must also be hot-dip galvanized after fabrication; mill galvanized covers are not acceptable for hot-dipped galvanized cable tray. All hot dip galvanized after fabrication steel cable trays must be returned to point of manufacture after coating for inspection and removal of all icicles and excess zinc. Failure to do so can cause damage to cables and/or injury to installers.
4. Stainless Steel: Straight section and fitting side rails and rungs shall be made of AISI Type 304 or Type 316 stainless steel.

2.3 TYPE OF TRAY SYSTEM

- A. Ladder type trays shall consist of two longitudinal members (side rails) with transverse members (rungs) swaged to the side rails. Rungs shall be spaced, [6] [9] [12] inches on center. Spacing in radiused fittings shall be 9 inches and measured at the center of the tray's width. No portion of the rungs shall protrude below the bottom plane of the side rails. **Each rung must be capable of supporting the maximum cable load, with a safety factor of 1.5 and a 200-pound concentrated load when tested in accordance with NEMA VE-1, section 5.4.
- B. I-Beam Ladder has side rails that are I-Beam profiles with rungs that are 1 1/8 square tubes with open slot facing down. These are of arc-welded construction.
 - 1. Standard Ladders & Ventilated/Trof consist of 1 1/8" Square tubular rungs with 6", 9", 12" Rung spacings 5" Rung spacing for Trof trays
·Rungs have large radius corners.
 - 2. Solid Bottoms trays consist of a solid, 0.040" flat sheet on top of ladder rungs on 12" centers. Bottoms can be located under rungs or located on top of and under rungs (double bottom)
- C. Ventilated trough type trays shall consist of two longitudinal members (side rails) with a corrugated bottom welded to the side rails. The peaks of the corrugated bottom shall have a minimum flat cable-bearing surface of 5/8 inch and shall be spaced 2 inches on center. To provide ventilation in the tray, the valleys of the corrugated bottom shall have 1/2 inch round holes punched along the width of the bottom.
- D. Solid bottom trough type trays shall consist of two longitudinal members (side rails) with a corrugated bottom welded to the side rails. The peaks of the corrugated bottom shall have a minimum flat cable-bearing surface of 5/8 inch and shall be spaced 2 inches on center.
- E. Tray Sizes shall have [3] [4] [5] [6] inch minimum usable load depth, or as noted on the drawing.
- F. Straight tray sections shall have side rails fabricated as C-Channels. All straight sections shall be supplied in standard [10] [12] [20] [24] foot lengths, except where shorter lengths are permitted to facilitate tray assembly lengths as shown on drawings.
- G. Tray widths shall be [6] [9] [12] [18] [24] [30] [36][42][48] inches or as shown on drawings.

2.4 CABLE TRAY ACCESSORIES

- A. All fittings must have a minimum radius of [12] [24] [36] [48] inches.

- B. Splice plates - shall be the bolted type made as indicated below for each tray type. The resistance of fixed splice connections between adjacent sections of tray shall not exceed .00033 ohms. Splice plate construction shall be such that a splice may be located anywhere within the support span without diminishing rated loading capacity of the cable tray.
1. Aluminum Tray - Splice plates shall be made of 6063-T6 aluminum, using ribbed neck spline bolts and serrated flange locknuts. Hardware shall be zinc plated in accordance with ASTM B633, SC1.
 2. Steel (including Pre-galvanized and Hot-dip galvanized) - Splice plates shall be manufactured of high strength steel, meeting the minimum mechanical properties of ASTM A1011 Grade 33. Each splice plate shall be attached with ribbed neck spline bolts and serrated flange locknuts. Hardware shall be zinc plated in accordance with ASTM B633 SC1 for pre-galvanized and hot-dip galvanized cable trays unless otherwise noted.
 3. Splice plates shall be furnished with straight sections and fittings.
- C. Cable Tray Supports - Shall be placed so that the support spans do not exceed maximum span indicated on drawings. Supports shall be constructed from 12-gauge steel formed shape channel members 1-5/8 inch by 1-5/8 inch with necessary hardware such as the Trapeze Support Kits T200E as manufactured by Atkore Cope Cable Tray. [or engineer approved equal]. Cable trays installed adjacent to walls shall be supported on wall mounted brackets such as Atkore Cope 9037 or 9036 series brackets [or engineer approved equal].
- D. Trapeze hangers and center-hung supports shall be supported by [3/8] [1/2] inch (minimum) diameter rods.
- E. Barrier Strips - Shall be placed as specified on drawings and be fastened into the tray with self-drilling screws or U-bolts with acorn nuts.
- F. Cable Tray Hold Downs – Cable tray supported on standard 1-5/8 inch strut shall be held down with Atkore Cope style hold-down brackets. Such as the 9131 series for ladder type cable trays and 90XX series for trough and hat series. 9132 or 9133 series hold downs to be used when supporting the cable tray vertically on standard 1-5/8-inch Atkore Power Strut or Atkore Unistrut.
- G. Cable Cleats - shall be Atkore Talon® T1 Cable Cleats or Atkore Talon® T3 cable cleats.
- H. Accessories - special accessories shall be furnished as required to protect, support, and install a cable tray system. Accessories shall consist of, but are

not limited to: section splice plates, expansion plates, blind-end plates, specially designed ladder dropouts, barriers, and hold down clips.

2.5 LOADING CAPACITIES

- A. Cable tray shall be capable of carrying a uniformly distributed load of [] lbs. /ft. on a [] foot support span with a safety factor of 1.5 when supported as a simple span and tested per NEMA VE1 Section 5.2. **In addition to the uniformly distributed load the cable tray shall support a 200 lb. concentrated load at mid-point of span and centerline of tray. **Load and safety factors specified are applicable to both side rails and rung capacities. **Omit as needed.

PART 3 EXECUTION

3.1 EXISTING WORK

3.2

- A. Contractor or approved sub-contractor to remove exposed abandoned cable tray, including abandoned cable tray above accessible ceiling finishes. Remove supports. Cut wire basket cable tray flush with walls and floors, and patch surfaces.
- B. Contractor or approved sub-contractor to maintain access to existing wire basket cable tray and other installations remaining active and requiring access. Modify installation or provide access panel.
- C. Contractor or approved sub-contractor to extend existing wire basket cable tray installations using materials and methods [compatible with existing electrical installations, or] as specified.
- D. Contractor or approved sub-contractor to clean and repair existing wire basket cable tray to remain or to be reinstalled.

3.3 INSTALLATION

- A. Install cable trays as indicated: Installation shall be in accordance with equipment manufacturer's instructions, and with recognized industry practices to ensure that cable tray equipment comply with requirements of NEC and applicable portions of NFPA 70B. Reference NEMA-VE2 for general cable tray installation guidelines.
- B. Coordinate cable tray with other electrical work as necessary to properly integrate installation of cable tray work with other work.
- C. Provide sufficient space encompassing cable trays to permit access for installing and maintaining cables.
- D. Cable tray fitting supports shall be located such that they meet the strength requirements of straight sections. Install fitting supports per NEMA VE-2 guidelines, or in accordance with manufacturer's instructions.

- E. In order for a system to be approved as an equipment ground conductor (EGC), all splicing assemblies shall be UL Classified or CSA approved as an EGC. For adjustable splices and expansion areas, copper bonding jumpers must be used when using the system as an EGC.
- F. Support trays and fasten to structure. Install supports at each connection point, at end of each run, and at other points to maintain spacing between supports of [] feet ([] cm) maximum. Use manufacturer recommended size for cantilever brackets. Installation of oversized or undersized cantilever brackets may lead to system failure.
- G. Cable tray should be free of burrs and sharp edges.
- H. Cable tray shall be grounded according to manufacturer's specifications.
- I. Divided cable runs shall be kept separate with a solid barrier.

3.4 TESTING

- A. Test cable trays to ensure electrical continuity of bonding and grounding connections, and to demonstrate compliance with specified maximum grounding resistance. See NFPA 70B for testing and test methods.
- B. Manufacturer shall provide test reports witnessed by an independent testing laboratory of the "worst case" loading conditions outlined in this specification and performed in accordance with the latest revision of NEMA VE-1; including test reports verifying rung load capacity in accordance with NEMA VE-1 Section 5.4.

Atkore - COPE

This product specification is written according to the Construction Specifications Institute
MasterFormat, 2018 Update.

SECTION 26 05 36

CABLE TRAYS FOR ELECTRICAL SYSTEMS (WIRE BASKET)

PART 1 GENERAL

1.1 SUMMARY

- A. Work covered under this Section 26 05 36 consists of furnishing of necessary labor, supervision, materials, equipment, tests and services to completely execute a complete wire basket cable tray system as described in this specification and as shown on the drawings.
- B. Wire basket cable tray systems are defined to include, but are not limited to: straight sections of continuous wire mesh, field formed horizontal and vertical bends, tees, drop outs, supports, and accessories.
- C. Related Sections:
 - 1. Section 26 05 26 - Grounding and Bonding for Electrical Systems.
 - 2. Section 26 05 29 - Hangers and Supports for Electrical Systems.

1.2 REFERENCES

- A. American Society for Testing and Materials (ASTM) International:
 - 1. ASTM A1011 / A1011M - Standard Specification for Steel, Sheet and Strip, Hot-Rolled, Carbon, Structural, High-Strength Low-Alloy, High-Strength Low-Alloy with Improved Formability, and Ultra-High Strength (*Formally ASTM A570 & A607*).
 - 2. ASTM A123 / A123M - Standard Specification for Zinc (Hot-Dip Galvanized) Coatings on Iron and Steel Products.
 - 3. ASTM A510 - Standard Specification for General Requirements for Wire Rods and Coarse Round Wire, Carbon Steel
 - 4. ASTM A513 - Standard Specification for Electric-Resistance-Welded Carbon and Alloy Steel Mechanical Tubing
 - 5. ASTM A580 – Standard Specification for Stainless Steel Wire

6. ASTM B633 - Standard Specification for Electrodeposited Coatings of Zinc on Iron and Steel
7. ASTM A641 / A641M - Standard Specification for Zinc-Coated (Galvanized) Carbon Steel Wire
8. ASTM A653 / A653M - Standard Specification for Steel Sheet, Zinc-Coated (Galvanized) or Zinc-Iron Alloy-Coated (Galvannealed) by the Hot-Dip Process.
9. ASTM D769 - Standard Specification for Black Synthetic Iron Oxide

B. National Electrical Manufacturers Association:

1. NEMA VE 1 - Metal Cable Tray Systems.
2. NEMA VE 2 - Cable Tray Installation Guidelines.

C. NFPA 70: National Electrical Code (2017)

D. ANSI/TIA-568-C.0 – Generic Telecommunications Cabling for Customer Premises

E. ANSI/TIA-569-B – Commercial Building Standard for Telecommunications Pathways and Spaces

1.3 DRAWINGS

- A. The drawings, which constitute a part of these specifications, indicate the general route of the wire basket cable tray systems. Data presented on these drawings is only as accurate as preliminary surveys and planning can determine until final equipment selection is made. Accuracy is not guaranteed and field verification of all dimensions, routing, structural loading, regional and national compliances are required.

1.4 QUALITY ASSURANCE

- A. Specifications and drawings are for assistance and guidance, but exact routing, locations, distances and levels will be governed by actual field conditions. Contractor is directed to make field surveys as part of his work prior to submitting system layout drawings.
- B. All cable and equipment shall be installed in a neat and professional manner. All methods of construction that are not specifically described or indicated in the contract documents shall be subject to the control and approval of the owner or owner's representative. Atkore does not warrant and shall not be liable for any claims or damages related to the installation of the products.
- C. Distributors to supply all equipment and accessories new and free from

defects.

- D. Distributors to supply all equipment and accessories in compliance with the applicable standards listed in Part 1.2 of this section and with all applicable national, state and local codes.
- E. Distributors to supply all items of a given type shall be the products of the same manufacturer.
- F. Manufacturers: Firms regularly engaged in manufacture of cable trays and fittings of types and capacities required, whose products have been in satisfactory use in similar service for not less than 5 years.
- G. Any zinc plated wire basket cable tray supplied by the distributor shall be classified by Underwriters Laboratories (UL).
- H. NEMA Compliance: Manufacturer to comply with NEMA Standards Publication Number VE1, "Cable Tray Systems".
- I. Installation by the contractor to comply with the National Electrical Code (NEC), as applicable, relating to construction and installation of cable tray and cable channel systems (Article 392, NEC).
- J. Installation by the contractor to comply with NFPA 70B, "Recommended Practice for Electrical Equipment Maintenance" pertaining to installation of cable tray systems.

1.5 DELIVERY, STORAGE AND HANDLING

- A. Onsite delivery of cable tray systems and components carefully to avoid breakage, denting and scoring finishes. Do not install damaged equipment.

1.6 Onsite storage of cable trays and accessories to be in in original cartons and in clean dry space; protect from weather and construction traffic. Wet materials should be unpacked and dried before storage.

1.7 SUBMITTALS

- A. Section 01 33 00 - Submittal Procedures: Submittal procedures.
- B. Submittal Drawings: Submit drawings of wire basket cable tray and accessories including connector assemblies, clamp assemblies, brackets, splice plates, splice bars, grounding clamps and hold-down plates showing accurately scaled components. Indicate wire basket

cable tray dimensions, support points, and finishes.

- C. Product Data: Submit manufacturer's data on wire basket cable tray system including, but not limited to, types, materials, finishes and inside depths.
- D. Manufacturer's Installation Instructions: Submit application conditions and limitations of use stipulated by Product testing agency specified under references. Include instructions for storage, handling, protection, examination, preparation, and installation of Product.

1.8 CLOSEOUT SUBMITTALS

- A. Section 01 70 00 - Execution and Closeout Requirements: Closeout procedures.
- B. Project Record Documents: Contractor to record actual routing of cable tray and locations of supports once the project is completed.

1.9 QUALIFICATIONS

- A. Manufacturer: Company specializing in manufacturing Products specified in this section with minimum [] years of documented experience, and with service facilities within [] miles of Project.

1.10 CONTRACTOR PRE-INSTALLATION MEETINGS

- A. Section 01 30 00 - Administrative Requirements: Pre-installation meeting.
- B. Convene a minimum of [] week(s) prior to commencing work of this section.

PART 2 PRODUCTS

1.1 NEMA VE 1 Class designation, indicated in the following specifications for metal cable tray, is support span in feet (meters) plus working load designation.

- A. Available Support Spans: 10 feet (3048mm)
- B. Working Load Designation:
 - A - 50 pounds per foot (74.4 kg/m).
 - B - 75 pounds per foot (111.6 kg/m).
 - C - 100 pounds per foot (148.8 kg/m).
- C. Consult NEMA VE 1 for additional information and safety factors.

2.1 ACCEPTABLE MANUFACTURERS

A. Subject to compliance with these specifications, wire basket cable tray systems to be installed shall be as manufactured by the following:

1. Atkore –
Cope 11500
Norcom Rd
Philadelphia, PA 19154
TOLL-FREE / 800-882-5543

2.2 WIRE BASKET CABLE TRAY SECTIONS AND COMPONENTS

A. Manufacturer to provide wire basket cable tray of types and sizes purchased with pre-welded splice bars. Manufacturer to construct units with rounded edges and smooth surfaces; in compliance with applicable standards; and with the additional construction highlighted in Section 2.2

B. All straight sections shall be constructed with a pre-welded splice plate to connect two runs of wire basket together. These splice bars must be UL approved for grounding with use of grounding clips.

C. Wire basket cable tray shall be made of high strength steel wires and formed into a standard 2 inch by 4-inch wire mesh pattern with intersecting wires welded together. All mesh sections must have at least one bottom longitudinal wire along entire length of straight section.

D. Wire basket cable tray sizes shall conform to the following nominal criteria ($\pm 10\text{mm}$):

1. Straight sections shall be furnished in standard 118.3 inch lengths.
2. Wire diameter shall be a uniform 0.177" (4.5mm), 0.197" (5mm), or 0.236" (6mm) on mesh sections.
3. Wire basket cable tray shall have a 2-inch usable loading depth by [2] [4] [6] [8] [12] [16] [18] [20] [24] inches wide.
4. Wire basket cable tray shall have a 4-inch usable loading depth by [4] [8] [12] [16] [18] [20] [24] inches wide.
5. Wire basket cable tray shall have a 6-inch usable loading depth by

[6] [8] [12] [16] [18] [20] [24] inches wide.

- E. In order for a system to be approved as an equipment ground conductor (EGC), all splicing assemblies shall be UL Classified or CSA approved as an EGC. When using powder coated wire mesh cable tray as an EGC, the paint must be completely removed at all contact points of splice/ground bolt attachments.
- F. Material and Finishes: Material and finish specifications for [Carbon Steel Wire] [Stainless Steel Wire] are as follows.
 - 1. Electro-Plated Zinc Galvanizing: Straight sections shall be made from steel meeting the minimum mechanical properties of ASTM A510, Grade 1008 and shall be electro-plated zinc in accordance with ASTM B633, Type III, SC-3.
 - 2. Stainless Steel: Straight sections and accessories shall be made from AISI Type [304] [316] stainless steel meeting the minimum mechanical properties of ASTM A580.
 - 3. Black Powder Coat: Straight sections shall be powder coated black with an average paint thickness of 1.2mils (30microns) to 3.0mils (75microns).
 - 4. Hot Dipped Galvanizing: Straight sections shall be made from steel meeting the minimum mechanical properties of ASTM A510, Grade 1008 and shall be hot dipped galvanized after fabrication in accordance with ASTM A123.
- G. All fittings shall be field formed from straight sections in accordance with manufacturer's instructions.
- H. Wire basket cable tray supports shall be center support hangers, trapeze hangers or wall brackets as manufactured by the Atkore Cope, Atkore Power Strut or Atkore Unistrut. .
- I. Special accessories shall be furnished as required to protect, support, and install a wire basket cable tray system.

PART 3 EXECUTION

3.1 EXISTING WORK

- A. Contractor or approved sub-contractor to remove exposed abandoned cable tray, including abandoned cable tray above accessible ceiling finishes. Remove supports. Cut wire basket cable tray flush with walls and floors, and patch surfaces.
- B. Contractor or approved sub-contractor to maintain access to existing wire

basket cable tray and other installations remaining active and requiring access. Modify installation or provide access panel.

- C. Contractor or approved sub-contractor to extend existing wire basket cable tray installations using materials and methods [compatible with existing electrical installations, or] as specified.
- D. Contractor or approved sub-contractor to clean and repair existing wire basket cable tray to remain or to be reinstalled.

3.2 INSTALLATION

- A. Install cable trays as indicated: Installation shall be in accordance with equipment manufacturer's instructions, and with recognized industry practices to ensure that cable tray equipment comply with requirements of NEC and applicable portions of NFPA 70B. Reference NEMA-VE2 for general cable tray installation guidelines.
- B. All trays should be supported using a minimum of ¼" All Threaded Rod.
- C. Special accessories shall be furnished as required to protect, support, and install a wire basket cable tray system.
- D. Coordinate wire basket cable tray with other electrical work as necessary to properly interface installation of wire basket cable tray with other work.
- E. Support trays and fasten to structure. Install supports at each connection point, at end of each run, and at other points to maintain spacing between supports of [] feet ([] cm) maximum. Use manufacturer recommended size for cantilever brackets. Installation of oversized or undersized cantilever brackets may lead to system failure.
- F. Ground and bond metal cable tray in accordance with NFPA 70, National Electrical Code, Article 392: Cable Trays.
 - 1. Provide continuity between wire basket cable tray components.
 - 2. Make connections to tray using mechanical, compression or exothermic connectors.
 - 3. If required, ground cable trays by mounting up to two [] AWG bare copper wires to each wire basket cable tray section, bonded with a grounding clamp.
- G. If required, install warning signs at [] feet ([] m) centers along

wire basket cable tray, located to be visible.

- H. Provide sufficient space encompassing wire basket cable tray to permit access for installing and maintaining cables.

3.3 TESTING

- A. Test wire basket cable tray support systems to ensure electrical continuity of bonding and grounding connections, and to demonstrate compliance with specified maximum grounding resistance. See NFPA 70B for testing and test methods.
- B. Manufacturer shall provide test reports witnessed by an independent testing laboratory of the "worst case" loading conditions outlined in this specification and performed in accordance with the latest revision of NEMA VE-1 ; including test reports verifying rung load capacity in accordance with NEMA VE-1 Section 5.4..



16100 South Lathrop Avenue
Harvey, IL 60426
Office 708-339-1610
Phone 800-882-5543
Web atkore.com

**CERTIFICATE OF COMPLIANCE
WITH BUY AMERICAN ACT**

July 1, 2024

To Whom It May Concern:

Aluminum Cope Cable tray products comply with the Buy American Act of 1933 (FAR 52.225, Sections 9-12), in that they are a non-ferrous construction material manufactured in the United States.

This certification has been issued for only the product listed for domestic compliance. Any alterations to this document by any other agency other than Atkore International voids the certification. This certificate is valid for 180 days from the date issued above.

Please contact me if you have any questions regarding this certification.

Sincerely,
Industry Affairs Team
Atkore International
Phone: 1-800-882-5543
Email: IndustryAffairs@atkore.com



16100 South Lathrop Avenue
Harvey, IL 60426

Office 708-339-1610

Phone 800-882-5543

Web atkore.com

**CERTIFICATE OF CONFORMANCE
BUY AMERICAN
TALON CLEATS**

July 1, 2024

To Whom It May Concern:

This certifies that the Talon cleats supplied by Atkore comply with the Buy American Act of 1933 (FAR 52.225, Sections 9-12) in that these products are manufactured in the U.S. and the cost of the product's components that are produced or manufactured in the United States exceed 65% of the cost of all of the components of the products.

This certification has been issued only for the product listed for domestic compliance. Any alterations to this document by any other agency other than Atkore International voids the certification. This certificate is valid for 180 days from the date issued above.

Atkore's Talon Cleats are manufactured in Houston, TX.

Please contact IndustryAffairs@atkore.com for further assistance regarding this certification.

Atkore Industry Affairs Team

Direct **1.800.882.5543**

Email **Industryaffairs@atkore.com**



Allied Tube & Conduit ▲ AFC Cable Systems ▲ Heritage Plastics ▲ Unistrut
Unistrut Construction ▲ Cope ▲ US Tray ▲ Calbrite ▲ Calbond ▲ Kaf-Tech
Columbia-MBF ▲ Eastern Wire + Conduit ▲ ACS/Uni-Fab ▲ Cii
Power-Strut ▲ Calconduit ▲ Razor Ribbon ▲ Calpipe Security
Vergokan ▲ Flexicon ▲ Marco

Atkore

16100 South Lathrop Avenue
Harvey, IL 60426

TOLL FREE / 800-882-5543
FAX / 708-339-7814

atkore.com/power-strut

Want to join a company that helps you build
the mindset, skill set and tool set for success?
Visit us at atkore.com/careers