



Mechanical Tube Capabilities



Atkore[™]
Allied Tube
& Conduit

Rethinking Mechanical Tubing

We don't make tubing. We create savvy solutions for your business.

In every application, an opportunity to be better.

Before we manufacture a single tube, we begin with a single purpose: To make your business better. Which means that with every customer, our manufacturing process actually begins with a learning process. We work to understand your business and identify opportunities for fresh creative thinking and unconventional answers.

At Allied Tube & Conduit, our business is developing customized, business savvy solutions that maximize profit and product performance for your business.

Our extensive product experience, applied to your unique business environment.

It's the unique challenges of your business and the demands of your critical applications that inspire us. In each challenge lies the opportunity to make tubing an integral and active part of your business, and not a mere commodity. Our customers typically come to us with an idea of what they'd like to achieve. And we work tirelessly to determine how to exceed their expectations.

**Larger solutions for today.
A partnership for tomorrow.**

Simply put, we're committed to being an active and important part of your business. Our new expanded larger size range can provide even greater design flexibility, including all the benefits of our in-line galvanizing process. From finding the right products to streamlining your supply chain to technical and marketing assistance, we're not just experts on tubing... we're experts on how tubing can work better for you every day.



The Allied Tube & Conduit Advantage



People

Allied Tube & Conduit has one of the largest staffs of engineers, technicians and customer service representatives in the industry. We are focused on listening to your needs, building long-lasting partnerships and becoming experts on your products and capabilities. This enables us to more effectively align our products to meet your needs by translating our experience into new ideas, new processes and new opportunities for you. We strive to build relationships with all of the people in your organization from upper management down through the ranks. In return, we hope that you will get to know our staff to develop a partnership that extends beyond the mere exchange of goods and services.

Products

As a leading supplier to industrial markets, we design products that reduce your operational costs while increasing performance to create solutions that will enable you to get the most out of your application. Allied Tube & Conduit's in-line galvanized tubing is engineered to eliminate production steps, reduce your overall steel weight and provide an overall application improvement. Our products lend themselves to be a solution to costly bottlenecks associated with paint, powder coating, hot-dip galvanizing or any other secondary coating operation. Our products will start working for you as soon as they reach your door foregoing multi-step cleaning and surface preparation processes.

Process

With our in-line galvanizing process, we create robust tubular solutions that make your production process more fluid. Our emphasis is to bring increased value to your product that will command a premium in its respective marketplace.

Flo-Coat® Process

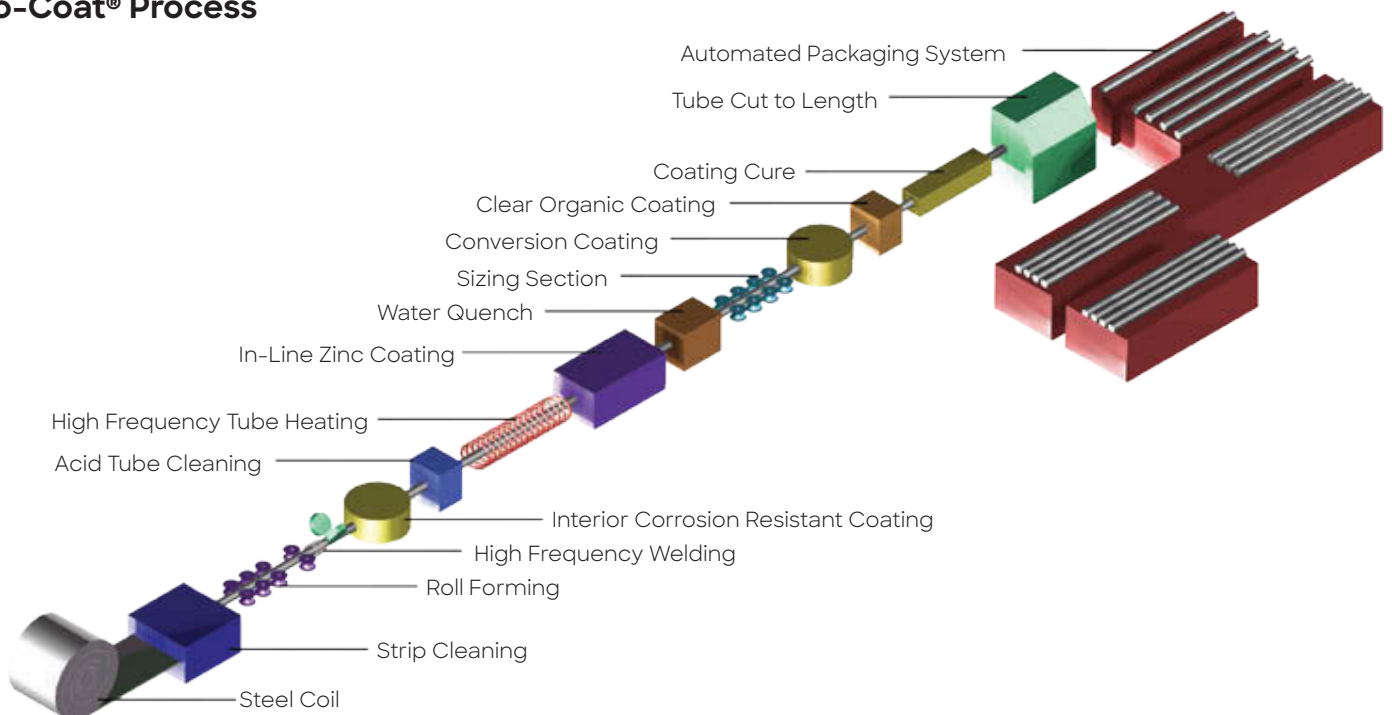

Fit For Use

A Complete Product Line

With such a wide-range of uses, Allied Tube & Conduit's in-line galvanized tubing must be versatile. Our capabilities include shapes such as: round, square, rectangle and flat-sided ovals. These shapes come in a number of different wall thicknesses (see WPF chart) for use in the majority of mechanical and structural applications.

With the addition of a new state of the art in-line mill, a wide variety of sizes and shapes are now an option, including even larger outer diameter tube dimensions. Allied Tube & Conduit's tubing is manufactured to ASTM A787 and ASTM A500 with coatings applied according to A1057. Custom requirements are available to meet your specific needs, including high strength steels.

Flo-Coat

Flo-Coat tubing is "the original in-line galvanized product." Developed first in 1959, Allied Tube & Conduit created a technique to run welded tubing through molten zinc utilizing our in-line process. Flo-Coat features advanced levels of corrosion protection, higher strength through cold forming and is designed to be paint and powder coat friendly.

Gatorshield

Gatorshield tubing is manufactured using the same in-line galvanizing process as our Flo-Coat product. A heavier layer of zinc is applied which provides additional corrosion protection. It is ideal for outdoor or high-moisture applications.

Square-Fit

Square-Fit's unique telescoping action gives flexibility in design and assembly of your product. Made with the latest high-speed roll forming technology, smaller sizes fit smoothly and snugly into the next larger size giving it the ability to telescope. It is available with and without holes. The product is available in a G90 pre-galvanized finish with clear organic Qwik-Coat.



The next time you park your car, go out shopping or make a cell phone call, it's most likely you'll encounter in-line galvanized tubing. Uses of Allied Tube & Conduit's in-line galvanized product include carports, cart corrals, greenhouses and cell towers. It's also used in industrial applications such as conveyor rollers, dairy stalls and to mount solar power equipment. So whether you are aware of it or not, in-line galvanized tubing is a part of your life. Allied Mechanical Tubing contains recycled steel and is also completely recyclable.

Gauge Range: 7 (0.188") - 22 (0.028")

Refer to the Allied Tube Conduit WPF chart for specific OD and gauge combinations

Typical Applications		
Flo-Coat	Gatorshield	Square Fit
Roller Conveyors	Dairy Stalls	Shelving Racks
Commercial Playgrounds	Greenhouses	Ceiling Grids
Farm Gates	Fabric Buildings	Conveyor Systems
Horse Trailers	Satellite Dishes	Material Handling Supports
Carports	Solar	Scaffolds

- Formable, heavy zinc layer
- no cracking or flaking
- Organic topcoat to fight white and red rust
- Zinc-based organic I.D. coating
- Fully covering the ID including the weld
- Inkjet Stenciling
- High-strength 50ksi yield typical on many products
- High strength steels available
- Hot-rolled and cold-rolled steel
- Both primary and secondary end cut conditions
- Expanded size range available

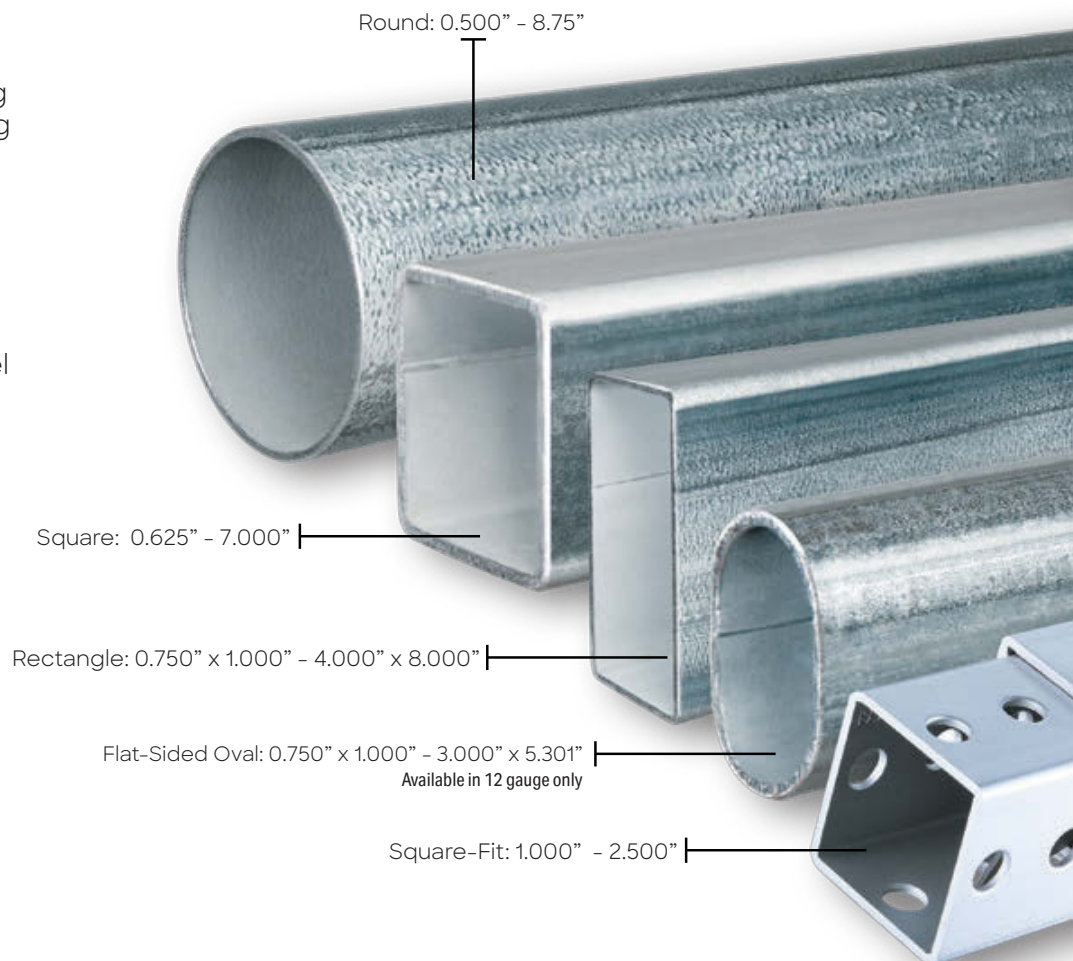

In-Line Advantage

Strength

We meet a minimum 50 ksi yield and 55 ksi tensile on many of our products with the ability to achieve even higher properties including HSLA grades. Compared to Schedule 40 pipe at 30 ksi, Allied Tube & Conduit's tubing provides a variety of higher strength alternatives.

Reduced Weight

Allied Tube & Conduit's tubing is adapted for the specific use of your applications. Our tube is produced by specific wall thickness rather than 1/16 or schedule pipe designations. Allied Tube & Conduit's tubing is demonstrative that strength is not represented by wall thickness alone, but rather by the appropriate combination of steel grade and yield/tensile properties, and our unique processing techniques.

Outstanding Corrosion Protection

Allied Tube & Conduit's signature in-line galvanizing process exhibits superior corrosion resistance by utilizing a triple layer of protection. First a 99.99% pure zinc coating is applied to the surface, followed by a conversion coating. The process is completed by adding a clear organic topcoat that seals the surface and produces a smooth shiny finished product unique to Allied Tube & Conduit. Exceptional corrosion protection is achieved by the collective performance of our three bonded coatings as compared to a single layer of zinc. Allied Tube & Conduit's tubing was designed for critical long-lasting applications, and is ideal for outdoor or high-moisture environments.

Weld Friendliness

Due to its 99.99% pure zinc uniform coating; Allied Tube & Conduit's tubing can be easily welded. Contrary to popular belief, all galvanized products do not perform the same with regards to welding suitability. Weld performance is an important feature of the Allied Tube & Conduit's tubing product and one that has made it a success in several marketplaces for over 50 years.

Formability

Allied Tube & Conduit's tubing is also capable of being fabricated using several different methods including hole punching, cutting, flattening, bending and more without the degradation of the coatings. All of these operations can be performed without cracking, flaking or otherwise damaging the integrity of the coating.

Custom Mill Lengths

There is nothing standard about our mill cut lengths. We produce the lengths that you require for your applications. Custom mill lengths from Allied Tube & Conduit allow you to minimize the scrap generated when having to cut standard lengths of pipe products.



Bus Bodies

Case Study

Problem:

A North American bus manufacturer desired added corrosion protection for its vehicles to stand up to harsher chemicals now being used to treat roads during the winter.

Solution:

Allied Tube & Conduit's Gatorshield in-line galvanized tubing. The heavier layer of zinc made Gatorshield ideal for this application. In addition to providing added corrosion protection the product was able to offer several other benefits. Due to its higher yield strength, Gatorshield enabled the manufacturer to switch to a lighter gauge steel. This resulted in a lower weight product and reduced shipping costs. Another added benefit was the ease of welding the product. The manufacturer worked with the Allied Tube & Conduit technical support team to develop a process utilizing their existing in-house equipment for properly welding the tubing. By switching to Allied Tube & Conduit's product the manufacturer was able to reduce labor costs, increase production and eliminate secondary processes. The end result was a longer life, safer vehicle at a reduced cost.

VS. The Alternatives

Flo-Coat/Gatorshield delivers excellent results when compared with alternative products

	Flo-Coat/ Gatorshield	Hot-Dip (Schedule 40)	Typical
Strength	50 ksi	30 ksi	40 ksi
Coatings	3 layers	1 layer	2 layers
Wall Thickness	Excellent	Limited	Good
Custom Mill Lengths	Any Length	Limited	Any Length
Weld Friendliness	Excellent	Poor	Fair
Zinc Thickness Control	Good	Limited	Limited
Mechanical Suitability	Excellent	Poor	Good
I.D. Weld Seam Coating	Excellent	Good	Poor

Process/ Capability	Flo-Coat	Gatorshield
Painting	x	
Powder Coating	x	
Storage		
Inside	x	x
Outside	x	x
Extreme Corrosive Conditions		x

Process/ Capability	Flo-Coat	Gatorshield
Fabrication		
Laser Cutting	x	x
Welding	x	x
Hole Punching	x	x
Bending	x	x
Swaging	x	x

Layers of Protection

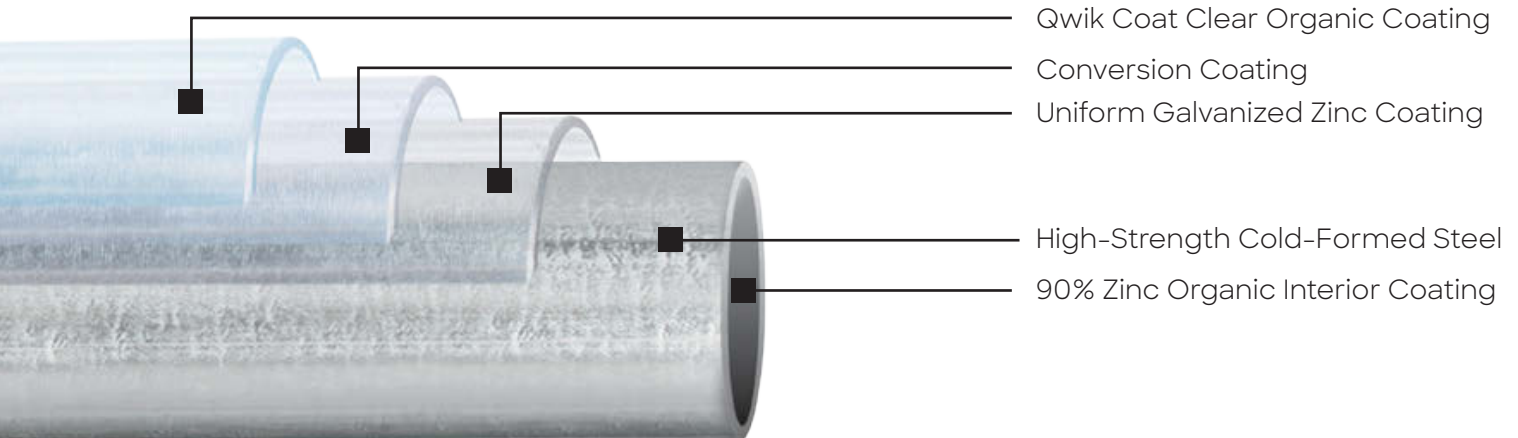

Strength - Corrosion Protection - Workability

Quality Fabrication

In addition to designing our products around your unique requirements, Allied Tube & Conduit offers a range of special fabrication services to provide assistance with product enhancement. Our mission is to reach beyond the supply of just tubular products and enhance our value through parts fabrication and assemblies.

Fabrication Capabilities

Assembly

Bending

Cutting

- Brand Saw
- Cold Saw
- Haven
- Tube Lasers

Packaging

Punching

Swaging

Welding

Cope/Notch



Fabric Covered Buildings

Case Study

Problem:

A North American fabric building manufacturer needed tubing that was not only strong, but fabricated well without degrading the coating. They also needed a single supplier who could meet the sizing requirements of different building designs

Solution:

Allied Tube & Conduit's Gatorshield in-line galvanized tubing. The availability in a number of OD and gauge combinations, used in conjunction with specific steel grades, allow the tube to meet certain strength requirements. The Gatorshield product demonstrated its ability to be fabricated by keeping the coating intact after bending, cutting or swaging. The end result was a leaner supply chain that produces fabric buildings more efficiently

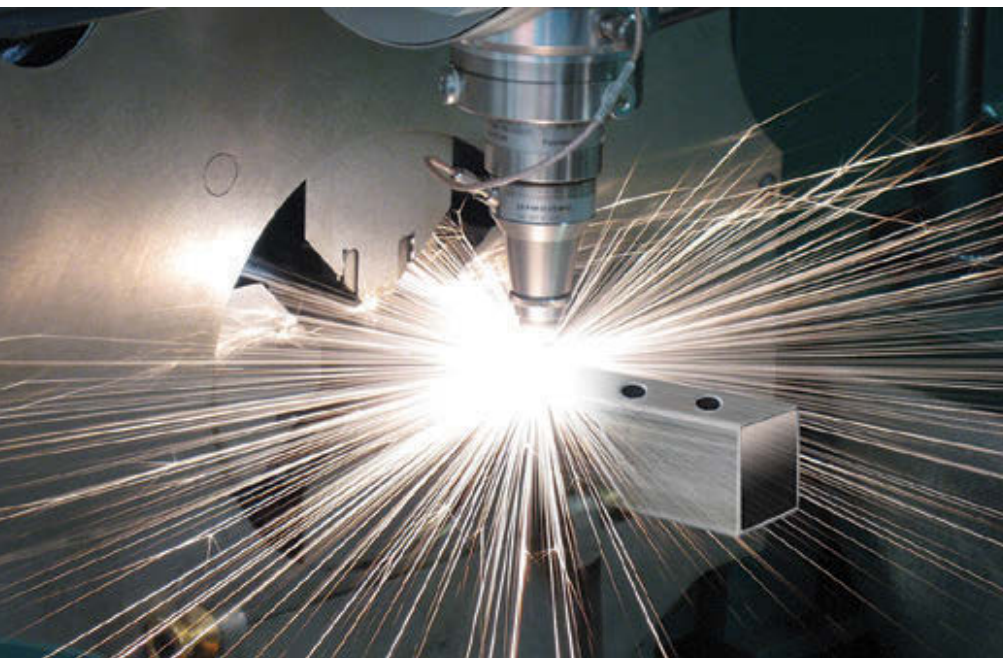

Technical Support

Allied Tube & Conduit has a staff of in-house engineers to provide assistance with your technical needs. They have a thorough knowledge of both mechanical and structural applications and are well-versed in working with steel. They are available to aid you in new product development or other technical needs.

Our engineers are able to assist you in areas such as new product introductions, design efficiency and fabrication processes. They are available for on-site consultations in order to assess your situation and tailor a solution that will optimize your end product. Our engineers have successfully reduced labor and freight costs, increased production and eliminated secondary processes for many customers.

Roller Conveyor Case Study

Problem:

A North American conveyor manufacturer was seeking a tube with a precision fit inside diameter to ensure that its conveyor system runs properly. Mechanical tube alternatives in the market did not adhere to required inside diameter tolerances causing an untrue roll and roller “noise”.

Solution:

Allied Tube & Conduit’s Flo-Coat in-line galvanized tubing. Allied Tube & Conduit engineers devised methods to perform inside diameter control on our line of Flo-Coat galvanized tubing, thus providing a remedy for conveyor roll applications. Due to control of the inside diameter the tolerance variation shifts to the outside diameter of the tube. This ensures a precise bearing fit. The end result is a better operating conveyor system with increased package handling efficiency.



Technical Support

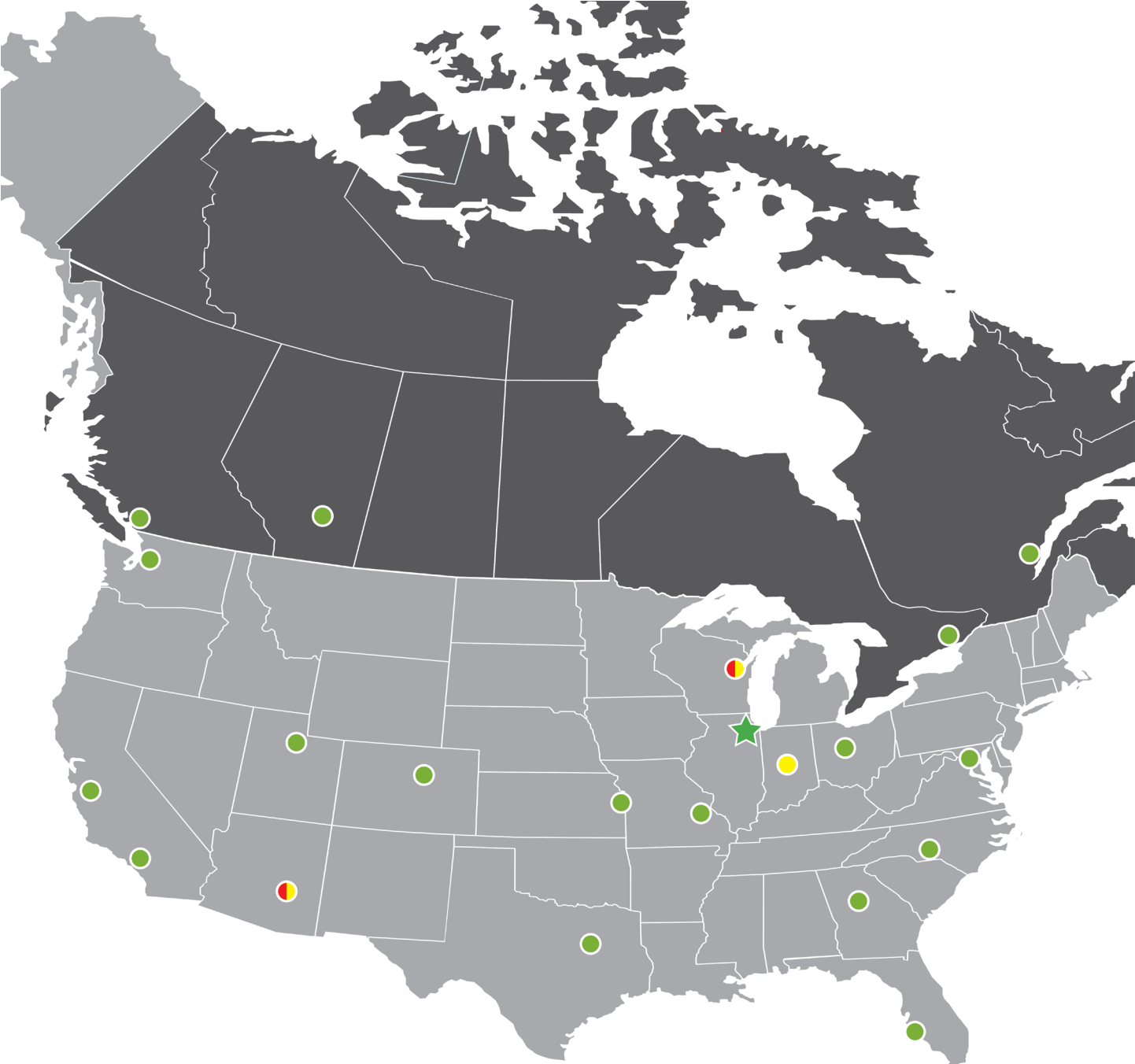

- ★ Harvey, IL HQ - Manufacturing and Fabrication Facility
- Manufacturing Facility
- Wholesale Distributors
- Fabrication Facility



Building better together.

As the leader in infrastructure solutions, Atkore has brought together the brands that you've trusted for years, allowing us to better partner with those who are building what's next.



Allied Tube & Conduit • AFC Cable Systems • Heritage Plastics • Unistrut • United Poly Systems • Razor Ribbon • Cope • US Tray • Calbrite
Calpipe Security • Unistrut Construction • Flexicon • Kaf-Tech • FRE Composites • ACS/Uni-Fab • Vergokan • Northwest Polymers • Cii • Power-Strut
Calbond • Elite Polymer Solutions • Cascade Poly Pipe • Conduit • Columbia-MBF • Queen City Plastics • Calconduit • Sasco Strut • Marco

Learn more at atkore.com



Allied Tube & Conduit ▸ AFC Cable Systems ▸ Heritage Plastics ▸ Cii ▸ Unistrut ▸ US Tray
Unistrut Construction ▸ Marco ▸ Calpipe Security ▸ Calbrite ▸ Calbond ▸ Flexicon ▸ Kaf-Tech
Power-Strut ▸ Calconduit ▸ FRE Composites ▸ United Poly Systems ▸ Sasco Strut ▸ Columbia-MBF
Elite Polymer Solutions ▸ Four Star Industries ▸ Eastern Wire + Conduit ▸ ACS/Uni-Fab ▸ Vergokan
Northwest Polymers ▸ Cascade Poly Pipe + Conduit ▸ Razor Ribbon ▸ Queen City Plastics ▸ Cope

Atkore
16100 S. Lathrop Ave.
Harvey, IL 60426

TOLL FREE / 800-882-5543
FAX / 708-339-7814

www.atkore.com

Want to join a company that helps you build
the mindset, skill set and tool set for success?
Visit us at atkore.com/careers